

Parts Catalog

Nautilus & Nautilus CE

Rider Scrubber/Sweeper

Models: Diesel, Gasoline, & LPG



PREFACE

Thank you for your purchase of the new industry standard for scrubber/sweepers. PowerBoss® takes great pride in offering the most dependable, reliable and best value in industrial power scrubbers and sweepers. We set the standard.

Our Customer Service Department would like to hear from you. If you see any errors, omissions or something that needs clarification in this Parts Catalog please let us know. We are working hard towards continually improving our processes to bring you the best you deserve. Please copy the form below, fill out and comment on how you found our catalog.

Thank you!
The PowerBoss Team

Name: _____

Title: _____

Company Name: _____

Address: _____

Country: _____

Type of equipment or model number: _____

Comments: _____

Please return to:
Customer Service Manager
PowerBoss®, Minuteman International, Inc.
14N845 U.S. Route 20
Pingree Grove, Illinois 60140 USA

Phone: (800) 323-9420
Email: tech@powerboss.com

This is the Parts Catalog for the PowerBoss® Nautilus Scrubber/Sweeper machine.

This catalog covers all Standard Nautilus machine variations beginning August 2015.

We believe this machine will provide excellent service for many years. Best results will be obtained if:

- The machine is operated with reasonable care.
- The machine is maintained regularly per the maintenance schedule provided in the User Manual.
- The machine is maintained with PowerBoss® supplied or equivalent parts.

All right side and left side references to the machine (except for engine) are determined by facing the direction of forward travel. The front of the engine or engine fan faces the front of the machine. Some hardware considered to be common or locally available has been omitted from the parts section to make this manual clear. Be sure to use equivalent hardware when replacement becomes necessary.

The Model and Serial Number of your machine is shown on the I.D. name plate. This information is needed when contacting Technical Support or when ordering parts. The I.D. plate is mounted on the left side wall of the operator seating area.

Example I.D Plate:

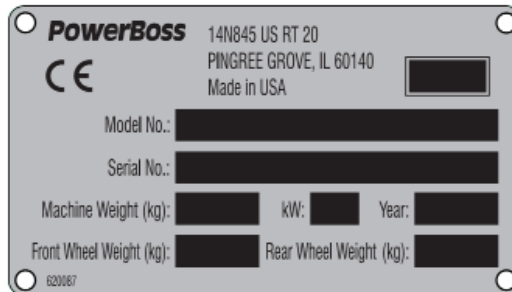

Parts may be ordered by phone, fax or e-mail from any PowerBoss® parts and service center. Before ordering parts or supplies, be sure to have your machine model number and serial number handy. For your convenience Fill out the data block below for future reference.

MACHINE DATA Fill out at installation	
Serial Number:	_____
Engine Serial Number:	_____
Sales Rep.:	_____
Date of Install:	_____

All information contained in this catalog is current at the time of printing. Minuteman International, Inc. reserves the right to make changes at any time without notice.

PowerBoss®, Minuteman International, Inc., Copyright 2014-2015, Printed in USA

TECHNICAL SPECIFICATIONS

Model: Nautilus Rider Scrubber/Sweeper
 Model No.: PB45DSL, PB45GAS, PB45LP

Nautilus CE Rider Scrubber/Sweeper
 PB45DSLCE, PB45GASCE, PB45LPCE

PB45DSLUK, PB45GASUK, PB45LPUK

GENERAL MACHINE SPECIFICATIONS

Length: 95.0 in (241.3 cm)
 Width with side scrub brush retracted: . . . 60.5 in (153.7 cm)
 Width with side scrub brush extended: . . . 65.5 in (166.4 cm)
 Height to lowest steering position: 60.5 in (153.7 cm)
 Height with overhead guard: 83.5 in (212.1 cm)
 Wheelbase: 47.75 in (121.3 cm)
 Front tires (molded): 16 in x 6 in
 (40 cm x 15 cm)
 Rear tires (press on): 18 in x 5 in
 (45 cm x 12 cm)
 Aisle width U-turn: 8 ft - 11.7 in (273.6 cm)
 Weight (Diesel engine) 4,047 lb (1836 kg)
 Weight (Gas & LPG engines) 4,027 lb (1826 kg)
 Maximum forward speed: 7.7 mph (12.4 km/h)
 Maximum reverse speed: 4.0 mph (6.4 km/h)
 Maximum climb angle (Traveling): 10 deg. (17% grade)
 Maximum climb angle (Scrubbing): 8 deg. (14% grade)

SCRUBBING SYSTEM

Cleaning path (main brushes) 45 in (114 cm)
 Cleaning path (w/optional side brush) . . . 60 in (152 cm)
 Main brush diameter: 12 in (30 cm)
 Main brush length: 45 in (114 cm)
 Main brush speed: 425 RPM
 Main brush force: 200 lb - 400 lb
 (90 kg - 181 kg)
 Side scrub brush diameter: 16 in (40 cm)
 Side scrub brush speed: 200 RPM
 Solution Tank capacity: 105 gal (397 L)
 Recovery Tank capacity: 105 gal (397 L)
 Demister chamber capacity: 17 gal (64 L)
 (2) Debris trays, total capacity: 2.1 ft³ (.059 m³)
 Vacuum fan speed: 11,500 RPM
 Vacuum water lift: 35 in (88 cm)

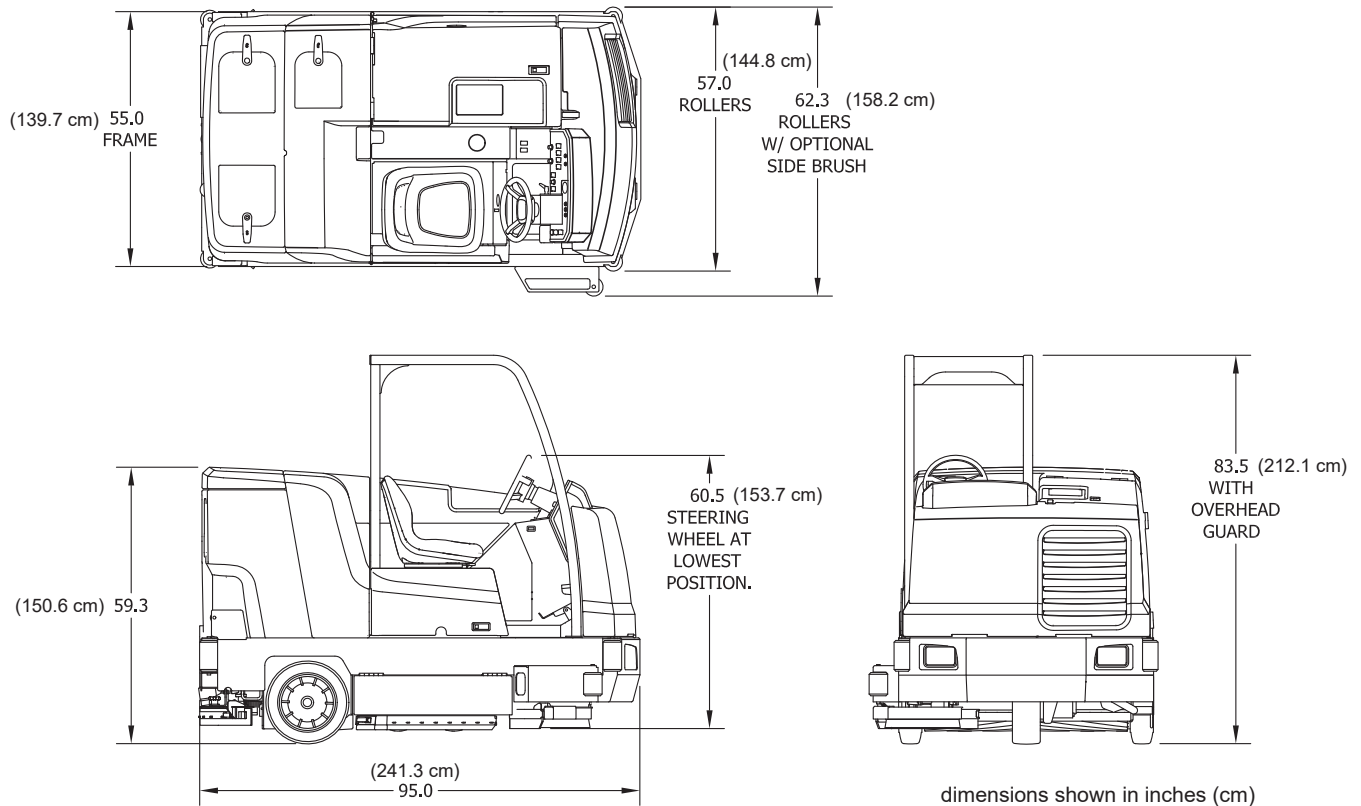

TABLE OF CONTENTS

PREFACE	2
TECHNICAL SPECIFICATIONS	4
PARTS BREAKDOWN	8
FRAME GROUP (730100)	8
BRAKE GROUP (730101)	10
REAR WHEEL GROUP (730105)	12
FRONT WHEEL GROUP (730102)	13
STEERING FORK GROUP (730103)	14
CONSOLE GROUP (730152)	16
STEERING COLUMN GROUP (730104)	18
INSTRUMENT PANEL GROUP - DIESEL (730108)	20
INSTRUMENT PANEL GROUP - GAS (730107)	22
INSTRUMENT PANEL GROUP - LPG (730106)	24
INSTRUMENTATION GROUP (730109)	26
ELECTRICAL BOX GROUP - DIESEL (730156)	28
DIRECTIONAL CONTROL GROUP (730110)	30
PUMP LINKAGE GROUP (730111)	32
SCRUB HEAD GROUP (730112)	34
SCRUB BRUSH LIFT GROUP (730113)	36
SCRUB BRUSH IDLER GROUP (730114)	38
BRUSH DOOR GROUP (730115)	40
SQUEEGEE LIFT GROUP (730119)	42
SQUEEGEE LINKAGE GROUP (730158)	44
SQUEEGEE GROUP (730118)	46
SIDE SQUEEGEE GROUP - RH (730120)	48
SIDE SQUEEGEE GROUP - LH (730157)	50
SOLUTION TANK GROUP (730121)	52
SOLUTION CONTROL GROUP (730123)	54
RECOVERY TANK GROUP (730122)	56
RECOVERY TANK DRAIN GROUP (730179)	58
PLASTIC HOPPER GROUP (730173)	60
HOPPER CRADLE GROUP (730174)	62
REAR BUMPER GROUP (730125)	64
REAR STEP GROUP (730055)	66
BUMPER LIFT GROUP (730159)	68
IMPELLER GROUP (730126)	70
IMPELLER HYDRAULIC MANIFOLD ASSEMBLY (730790-1)	72
HYDRAULIC RESERVOIR GROUP (730127)	74
HYDRAULIC PUMP GROUP (730136)	76
HYDRAULIC VALVE GROUP (730137)	78
HYDRAULIC MANIFOLD COMPONENTS GROUP (730170)	80
ENGINE MOUNT GROUP - DIESEL (730128)	82
ENGINE MOUNT GROUP - GAS (730164)	84

ENGINE MOUNT GROUP - LPG (730163)	86
AIR CLEANER GROUP - DIESEL (730131)	88
AIR CLEANER GROUP - GAS (730129)	90
AIR CLEANER GROUP - LPG (730130)	92
RADIATOR GROUP (730132)	94
RADIATOR OVERFLOW BOTTLE GROUP (730133)	96
OIL COOLER GROUP (730134)	98
EXHAUST GROUP - DIESEL (730154)	100
EXHAUST GROUP - GAS / LP (730178)	102
FUEL TANK MOUNT GROUP - DIESEL (730140)	104
FUEL TANK MOUNT GROUP - GAS (730139)	106
LPG TANK MOUNT GROUP (730138)	108
CE LPG TANK MOUNT GROUP (730138-CE)	110
FUEL LINE GROUP - DIESEL (730153)	112
FUEL COMPONENT GROUP - GAS (730141)	114
THROTTLE SOLENOID GROUP - DIESEL (730151)	116
BATTERY GROUP (730142)	118
FRONT COVER GROUP (730143)	120
TOP COVER GROUP (730144)	122
SIDE DOOR GROUP (730145)	124
SEAT DOOR GROUP (730146)	126
SEAT MOUNT GROUP (730147)	128
HYDRAULIC HOSE GROUP (730148)	130
HOSE CLAMP GROUP (730149)	132
DECAL GROUP (730150)	134
ELECTRICAL GROUP (730116)	136
BRUSH/BROOM GROUP (730175)	138
OPTIONS - PARTS BREAKDOWN	140
OPTION - SIDE BRUSH GROUP (730000)	140
OPTION - SIDE BRUSH LIFT GROUP (730001)	142
OPTION - SIDE BRUSH SOLUTION CONTROL GROUP (730002)	144
OPTION - SIDE BRUSH HYDRAULIC HOSE GROUP (730011)	146
OPTION - SIDE BRUSH SCRUB HEAD GROUP (730028)	148
OPTION - SIDE BRUSH STEERING COLUMN GROUP (730029)	149
OPTION - SSB HYDRAULIC MANIFOLD GROUP (730171)	150
OPTION - OVERHEAD GUARD GROUP (730003)	152
OPTION - LIGHT GROUP (ON OVERHEAD GUARD) (730189)	154
OPTION - SUSPENSION SEAT GROUP (730007)	156
OPTION - BACKUP ALARM GROUP (730008) STANDARD ON CE AND UK MODELS	158
OPTION - SEAT BELT (FOR SUSPENSION SEAT) GROUP (730009)	160
OPTION - SEAT BELT (FOR STANDARD SEAT) GROUP (730010)	162
OPTION - LIGHT GROUP (ON SOLUTION TANK) (730189-4)	164
OPTION - CHEMICAL METERING GROUP (730015)	166
OPTION - FIRE EXTINGUISHER GROUP (730016)	168

OPTION - AUTO FILL GROUP (730017)	170
OPTION - SPRAY AND VAC WAND TOOL GROUP (730021 - PART 1)	172
OPTION - SPRAY AND VAC WAND HOSE GROUP (730021 PART 2)	174
OPTION - SPRAY AND VAC WAND MOUNT GROUP (730022)	176
OPTION - SPRAY AND VAC WAND PUMP GROUP (730023)	178
OPTION - URETHANE SQUEEGEE BLADE GROUP (730024)	180
OPTION - URETHANE SIDE BRUSH SQUEEGEE GROUP (730025)	182
OPTION - STAINLESS STEEL HOPPER GROUP (730027)	184
OPTION - SEAT SWITCH (730031) STANDARD ON CE AND UK MODELS	186
OPTION - SIDE BROOM GROUP (730032)	188
OPTION - SIDE BROOM LIFT AND ADJUSTMENT GROUP (730033)	190
OPTION - SIDE BROOM HYDRAULIC HOSE GROUP (730034)	192
OPTION - SIDE BRUSH HYDRAULIC HOSE ROUTING (730038)	194
OPTION - SPRAY AND WASH GROUP (730040)	196
OPTION - PRESSURE WASHER PUMP GROUP (730041-1)	198
OPTION - PRESSURE WASHER HOSE AND WAND GROUP (730041-2)	200
OPTION - PRESSURE WASHER HYDRAULIC HOSE GROUP (730041-3)	202
OPTION - LOW LP INDICATOR GROUP (730042)	204
OPTION - SIDE BROOM WATER MIST GROUP (730043)	206
OPTION - REAR SQUEEGEE GUARD (730048)	208
OPTION - PVC FREE COMPONENTS (730049)	210
OPTION - TIE DOWNS (730026)	211
OPTION - FRONT WHEEL FENDER (730052)	212
OPTION - DRY SWEEP - PUMP (730053-1)	214
OPTION - DRY SWEEP - SKIRT (730053-2)	216
OPTION - DRY SWEEP - RADIATOR GRILLE (730053-3)	218
OPTION - DRY SWEEP - WATER MIST (730053-4)	220
OPTION - HEATED SOL GROUP, COIL TYPE, LP (730057)	222
OPTION - HEATED SOL GROUP, COIL TYPE, DSL (730058)	224
OPTION - RESERVE LPG TANK GROUP (730160)	226
OPTION - LIGHT GROUP WHEN CHEMICAL METERING AND RESERVE LPG TANK INSTALLED (730189-5)	228
OPTION - BACKUP ALARM GROUP - CM, RESERVE LPG IN (730169)	230
OPTION - PRESSURE WASHER (731457)	232
OPTION - DUST SUPPRESSION (731482)	234
MISCELLANEOUS ADDITIONAL OPTIONS	236
LAYOUTS - ELECTRICAL/HYDRAULIC	237
ELECTRICAL SCHEMATIC LAYOUT	237
ELECTRICAL SCHEMATIC LAYOUT (POINT TO POINT WIRING)	242
HYDRAULIC SYSTEM LAYOUT	247
HYDRAULIC SYSTEM LAYOUT WITH OPTIONAL SIDE SCRUB BRUSH	248
TIMER DIP-SWITCH SETTINGS	249

PARTS BREAKDOWN

FRAME GROUP (730100)

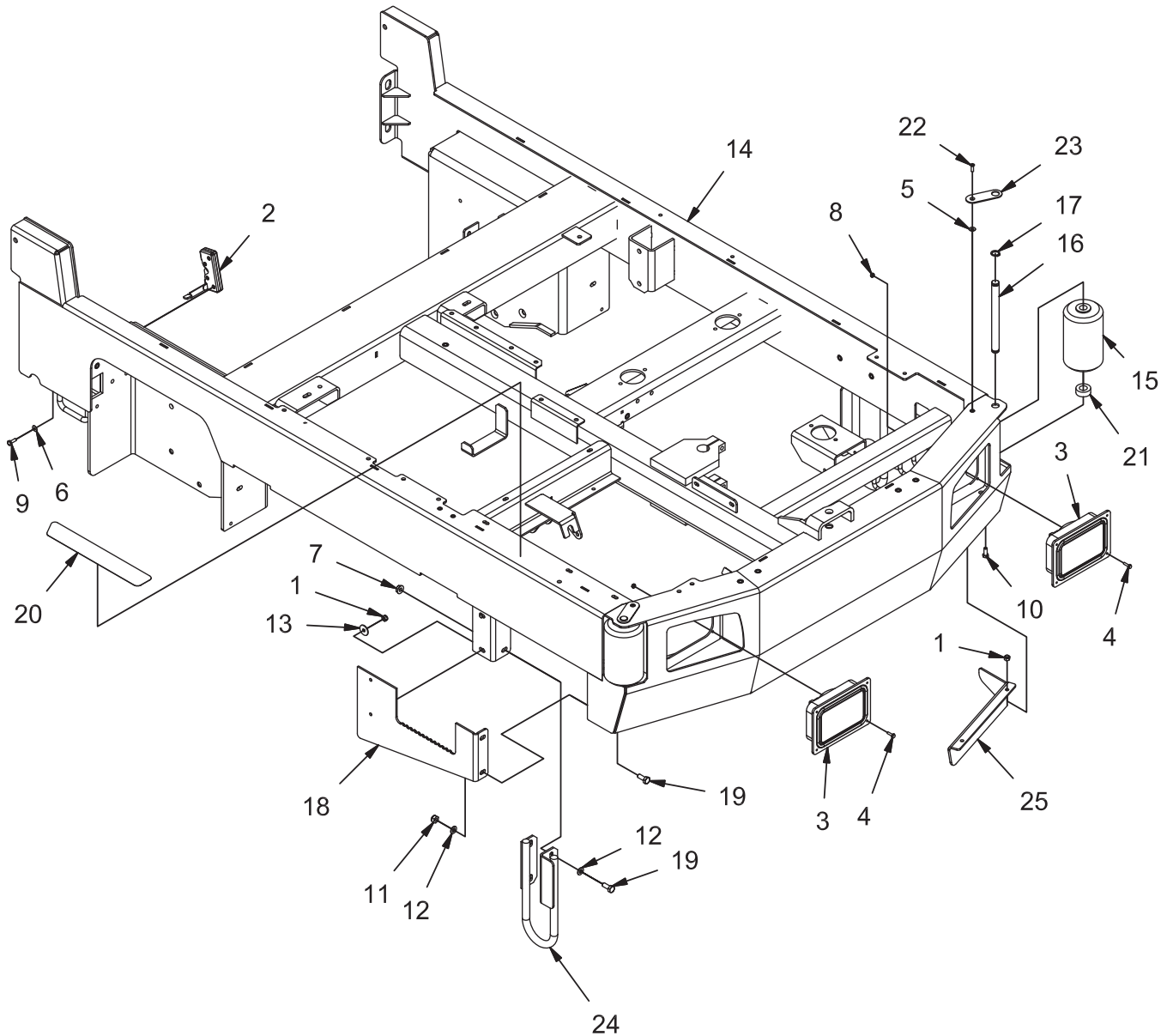

REV J

FRAME GROUP (730100)

Parts List 730100			
ITEM	PART NUMBER	QTY	DESCRIPTION
1	12040259	4	NUT, M8-1.25 ESN SS
2	3307247	1	LATCH, RH
3	681044	2	HEADLIGHT 12V
4	3400044	8	SCR-HEX, #10-32 X .75 ZP
5	3400089	2	WASHER, 1/4 .625 X .281 X .063
6	3400383	4	WASHER, 1/4 BELLEVILLE
7	600936	4	NUT, M10-1.50 FLNG
8	711350	8	NUT, 10-32, ESN
9	712562	4	SCREW, 1/4-20 X .75 HH SS
10	717030	2	BOLT, M8-1.25 X 20 HH SS
11	730339	2	NUT, M10-1.50 ESN SS
12	730344	6	WASHER, M10 SS
13	730526	2	WASHER, M8 FENDER SS
14	730550-1	1	ASSEMBLY, FRAME
15	730719	2	ROLLER
16	730876	2	PIN, ROLLER
17	730877	2	RETAINING RING, EXT, .750
18	730919	1	ASSEMBLY, COVER
19	730958	6	BOLT, M10-1.50 X 25 HH SS
20	730967	1	PAD, STEP
21	730975	2	SPACER, .813 B 1.50 OD .56 T
22	731382	2	SCREW, M6-1.00 X 20 FLAT SHCS ZP
23	731388	2	RETAINER, ROLLER PIN
24	731509	1	WELDMENT, RIGHT GUARD
25	731559	1	GUARD, EXHAUST

BRAKE GROUP (730101)

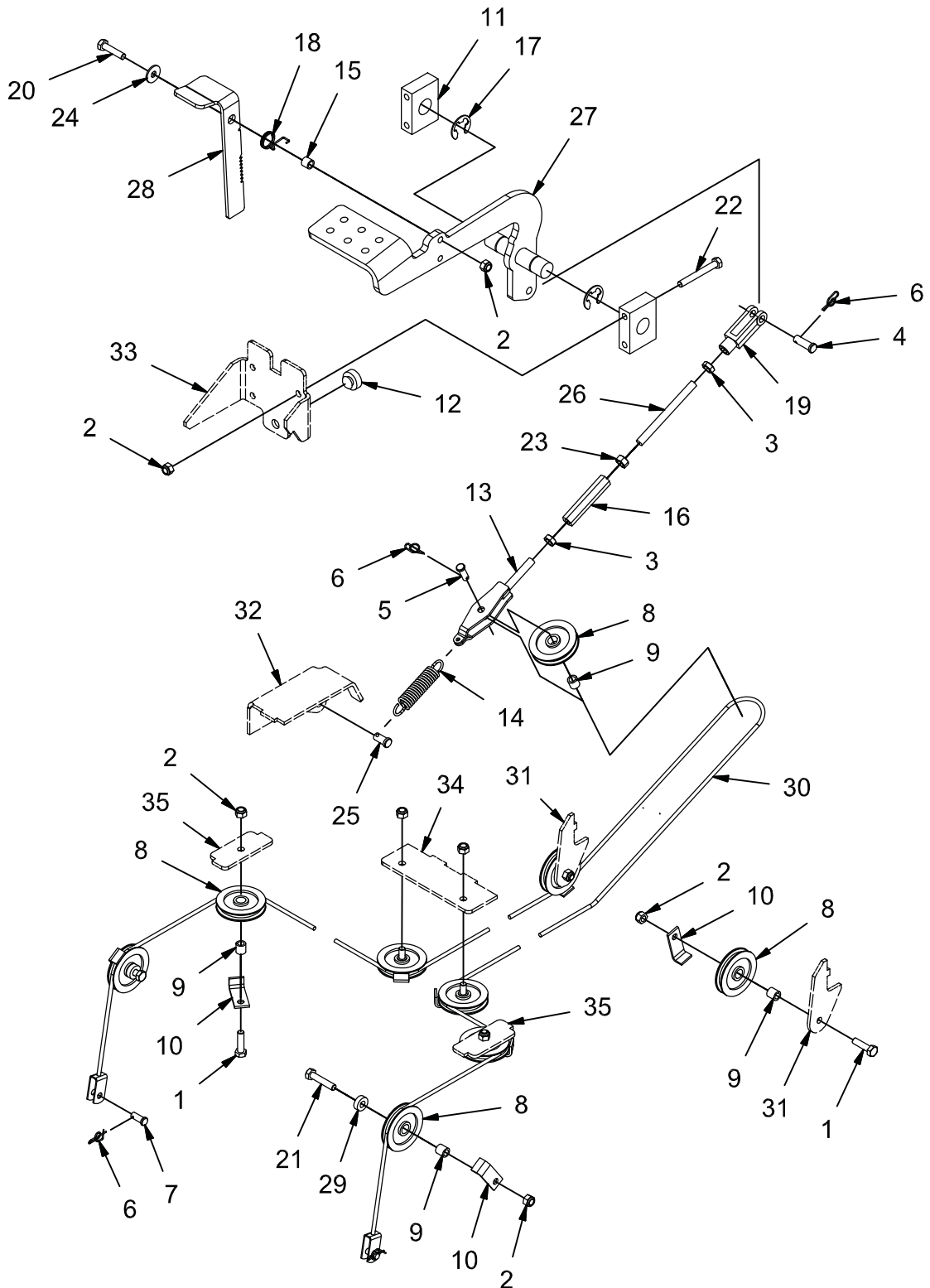

REV *

BRAKE GROUP (730101)

Parts List 730101			
ITEM	PART NUMBER	QTY	DESCRIPTION
1	11038254	6	BOLT, M8-125 X 30 HH
2	12040051	13	NUT, M8-1.25 ESN
3	3400075	2	NUT, HEX JAM 3/8-24
4	3400117	1	PIN, CLEVIS 3/8 X 1.125
5	3400118	1	PIN, CLEVIS, .313 X .88
6	3400125	4	RUE-RING, .375
7	450034	2	PIN, CLEVIS, .313 X .75
8	600113	9	PULLEY, .50 B, 2.00 D, .44 T
9	600114	9	SPACER, .328 B .498 OD .500 T
10	600115	8	RETAINER, CABLE
11	600116	2	BLOCK, BRAKE PIVOT
12	600117	1	BUMPER, 1.00 X .339 T
13	600121	1	CLEVIS, BRAKE PULLEY
14	600127	1	SPRING, EXT, .105 W .75 OD 3.50 L
15	600315	1	SPACER, .344 B .485 OD .425 T
16	600338	1	TURNBUCKLE, .375
17	600570	2	E-RING, .88
18	600809	1	SPRING, TORSION
19	600813	1	CLEVIS, 3/8-24
20	600918	1	BOLT, M8-125 X 35 HH
21	600919	2	BOLT, M8-1.25 X 40 HH
22	600921	4	BOLT, M8-1.25 X 65 HH
23	600938	1	NUT, 3/8-24 LH
24	600940	1	WASHER, M8 FENDER
25	711679	1	PIN, CLEVIS, .375 X .75
26	730369	1	ROD, BRAKE ADJ
27	730370	1	WELDMENT, BRAKE PEDAL
28	730372	1	PEDAL, PARKING BRAKE
29	730374	2	SPACER, .344 ID .75 OD .25 T
30	730375	1	CABLE, BRAKE
31	REF.	-	FRAME
32	REF.	-	FRAME
33	REF.	-	CONSOLE
34	REF.	-	FRAME
35	REF.	-	FRAME

REAR WHEEL GROUP (730105)

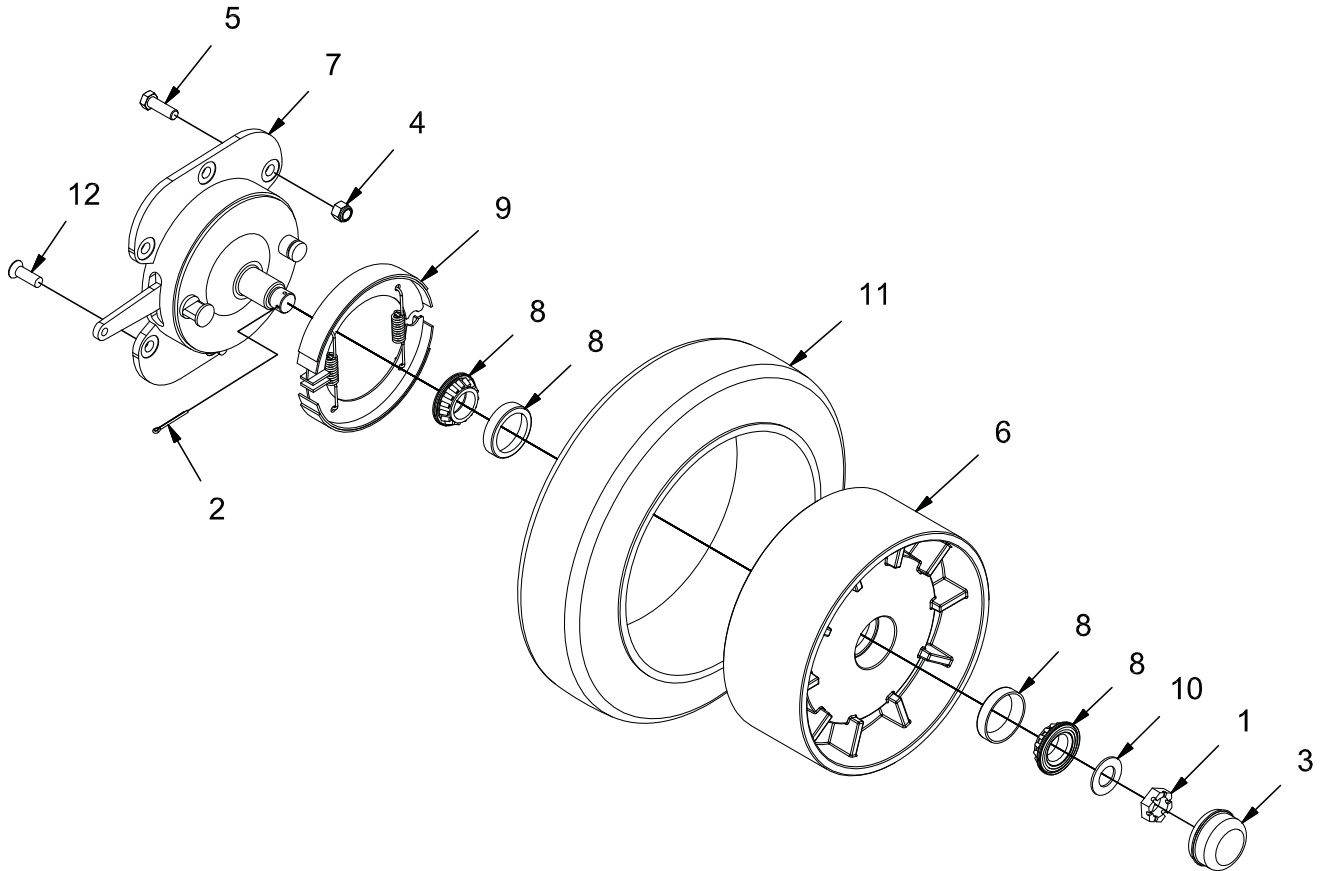

Parts List 730105			
ITEM	PART NUMBER	QTY	DESCRIPTION
1	3400223	2	NUT, 1-20 SLOTTED ZP
2	380-632-20	2	PIN, COTTER .125 X 1.50 ZP
3	383250	2	GREASE CAP
4	711376	12	NUT, FIBER INSERT 1/2-13
5	712047	6	SCREW, 1/2-13 X 1.50 HHC
6	730314	2	RIM, 18"
7	730316	2	ASSEMBLY, BRAKE-AXLE
8	730353	4	BEARING SET, 1.38 BORE CUP AND CONE
9	730357	-	BRAKE SHOE REPLACEMENT KIT
10	730358	2	SPACER, 1.03 B 1.88 OD .105 T
11	730359	2	TIRE, PRESS ON, 18 X 5
12	731100	6	SCREW, .50-13 x 1.50 FHCS ZP

REV *

FRONT WHEEL GROUP (730102)

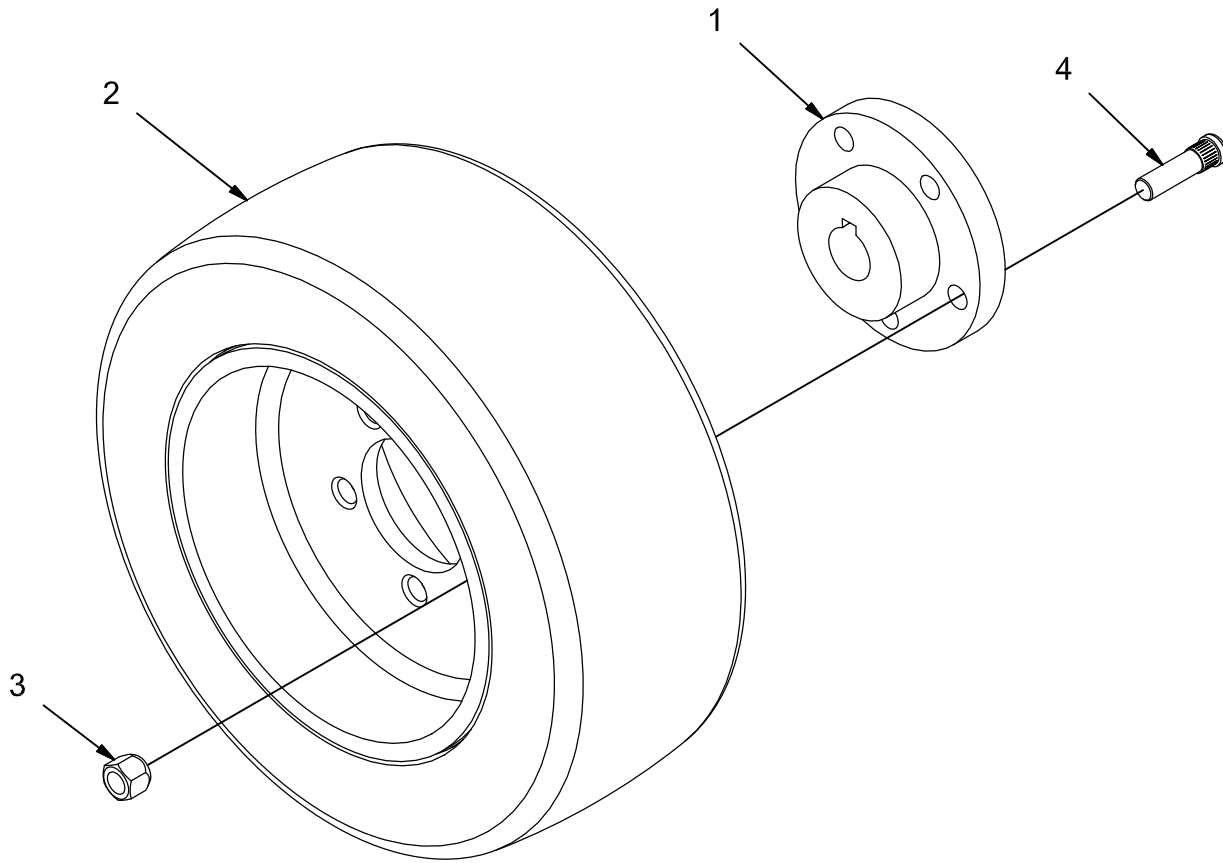

Parts List 730102			
ITEM	PART NUMBER	QTY	DESCRIPTION
1	3316056	1	HUB, REAR WHEEL PNTD FULL
2	3316330	1	ASSEMBLY, TIRE AND RIM 16" PRESS-ON
3	3316057	5	NUT, LUG, 9/16-18
4	713526	5	STUD, WHEEL

REV A

STEERING FORK GROUP (730103)

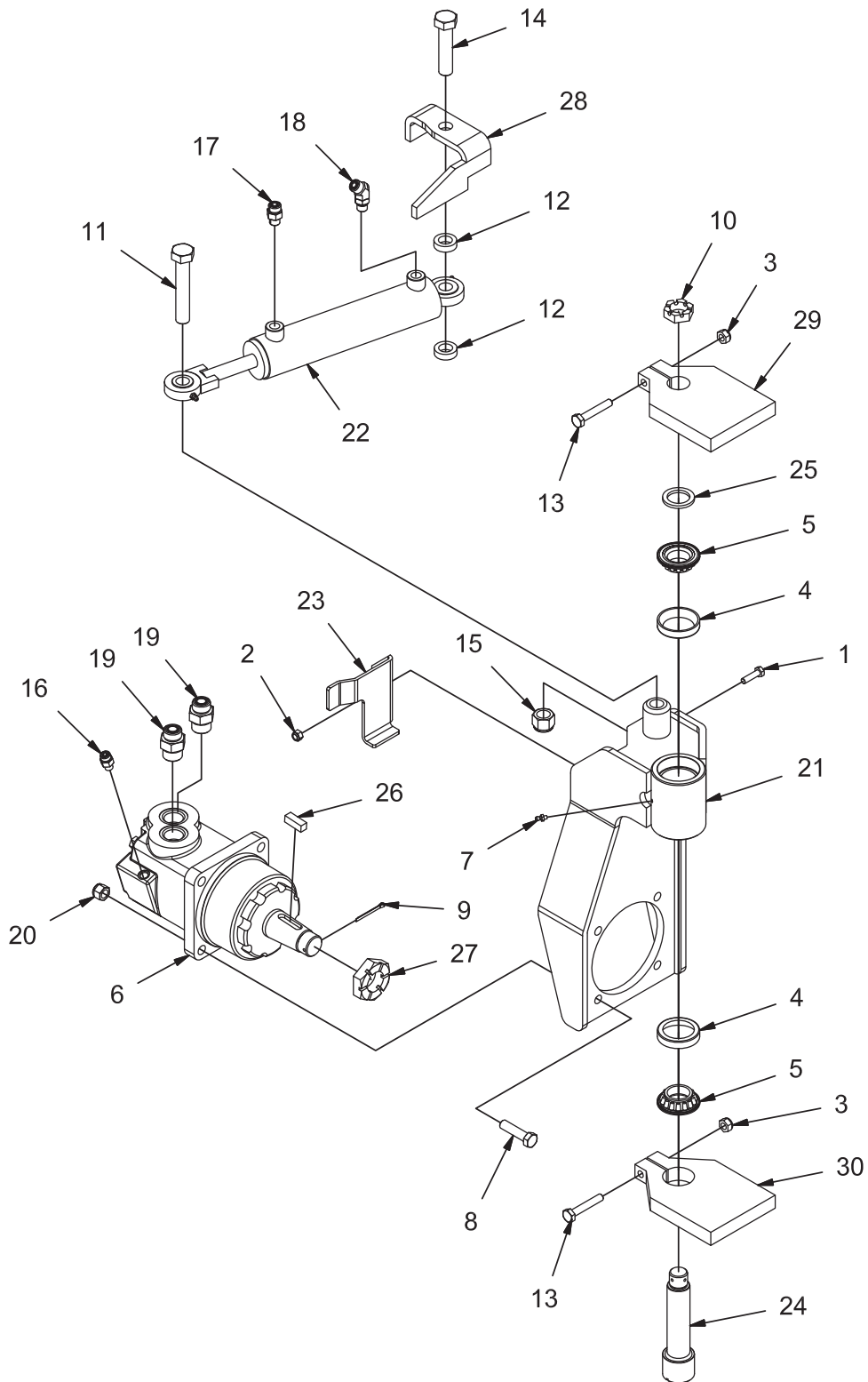

REV C

STEERING FORK GROUP (730103)

Parts List 730103			
ITEM	PART NUMBER	QTY	DESCRIPTION
1	11038254	1	BOLT, M8-125 X 30 HH
2	12040051	1	NUT, M8-1.25 ESN
3	12040069	2	NUT, M10-1.50 ESN
4	3300470	2	BEARING, PIVOT BEARING - CUP
5	3300471	2	BEARING - CONE W/SEAL
6	3305108	1	MOTOR, HYD. WHEEL
7	3400012	3	GREASE ZIRK
8	3400020	4	BOLT, 1/2-13 X 2.00 HH
9	3400122	1	COTTERPIN .125 X 2.00
10	3400223	1	NUT, 1-20 SLOTTED ZP
11	731426	1	BOLT, 3/4-10 X 4.25 HH STL ZP
12	731427	2	SPACER, .766 B 1.25 OD .375 T
13	600925	2	BOLT, M10-1.50 X 60 HH
14	600932	1	BOLT, 3/4-10 X 3.25 HH
15	620059	1	NUT, 3/4-10 FIBER INSERT STL ZP
16	675508	1	FITTING, STR, 4 ORFS - 4-SAE
17	675515	1	FITTING, STR, 6 ORFS - 6 SAE
18	675552	1	FITTING, 45, 6 ORFS - 6 SAE
19	675578	2	FTG, STR, -12 ORFS TO -12 SAE
20	711376	4	NUT, FIBER INSERT 1/2-13
21	730300	1	WELDMENT, STEERING FORK
22	730307	1	CYLINDER, STEERING
23	730312	1	RETAINER, HOSE
24	730351	1	PIN, PIVOT
25	730352	1	SPACER, 1.255 B 1.75 OD .166 T
26	PART OF 3305108	1	KEY .44 SQ X 1.25
27	PART OF 3305108	1	NUT 1.25-18
28	REF.	-	FRAME
29	REF.	-	FRAME
30	REF.	-	FRAME

CONSOLE GROUP (730152)

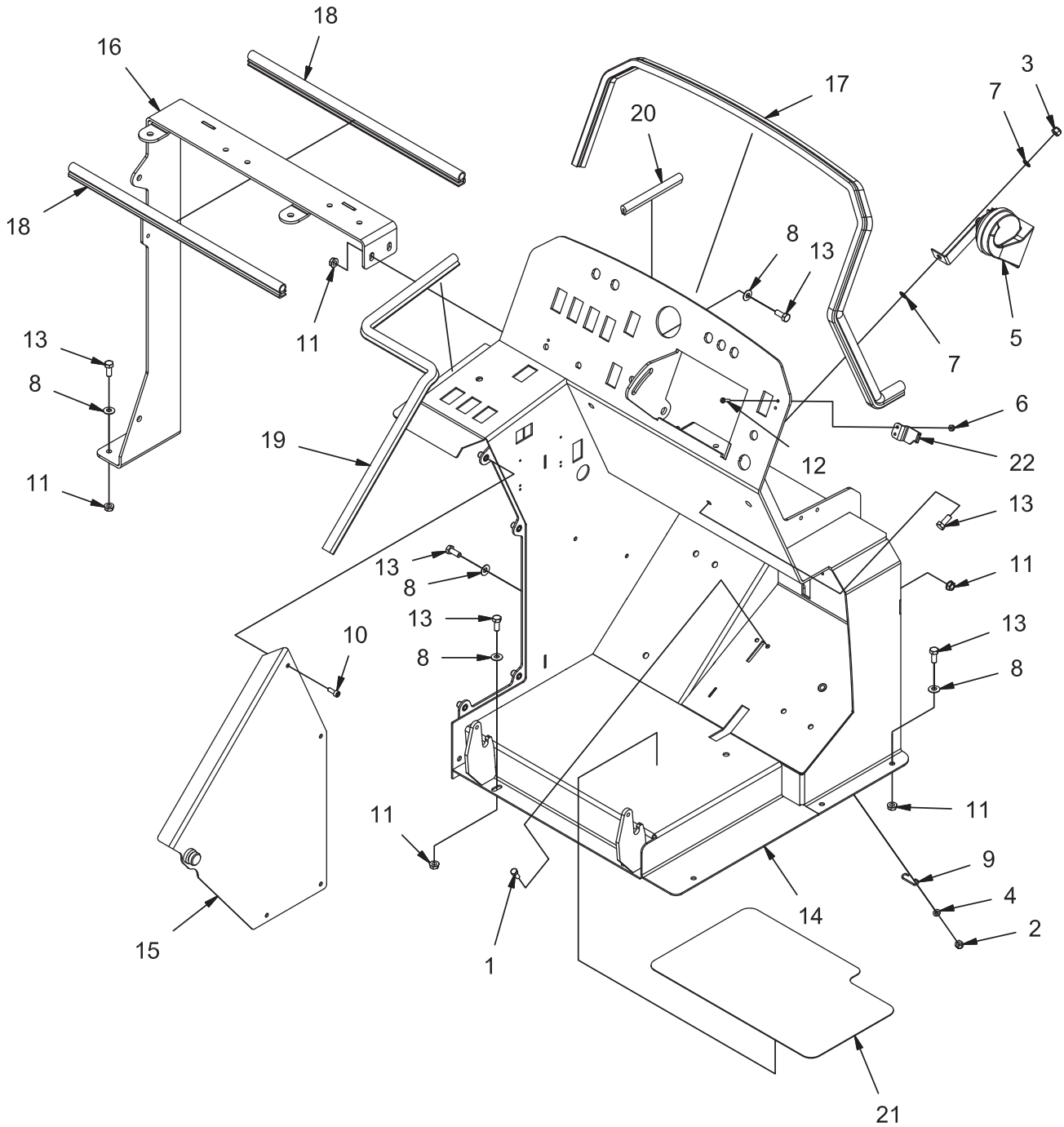

REV K

CONSOLE GROUP (730152)

Parts List 730152			
ITEM	PART NUMBER	QTY	DESCRIPTION
1	11038072	2	BOLT, M6-1.00 X 16 HH
2	12040044	2	NUT, M6-1.00 ESN
3	12040259	1	NUT, M8-1.25 ESN SS
4	12310033	2	WASHER, M6
5	3300379	1	HORN, 12V
6	3400082	2	NUT, FIBER INSERT #8-32
7	3400273	2	WASHER, STAR, .31, INT. ZP
8	3400384	11	WASHER, 5/16 BELLEVILLE
9	600125	1	CATCH, PARKING BRAKE
10	600912	4	BOLT, M6-1.00 X 16 SHCS
11	600934	11	NUT, M8-1.25 FLNG
12	710230	2	SCREW, #8-32 X .62 PAN HD
13	717024	12	BOLT, M8-1.25 X 20 HH
14	730376-1	1	ASSEMBLY, CONSOLE
15	730396	1	WELDMENT, CONSOLE COVER
16	730401	1	WELDMENT, COVER FRAME
17	730536	1	SEAL, BULB, 50.50 LG
18	730537	2	SEAL, BULB
19	730538	1	SEAL, BULB, 30.00 LG
20	730543	1	EDGING, 1/8 X 5.25"
21	730988	1	PAD, FLOOR
22	731435	1	CONSOLE, STRIKER

STEERING COLUMN GROUP (730104)

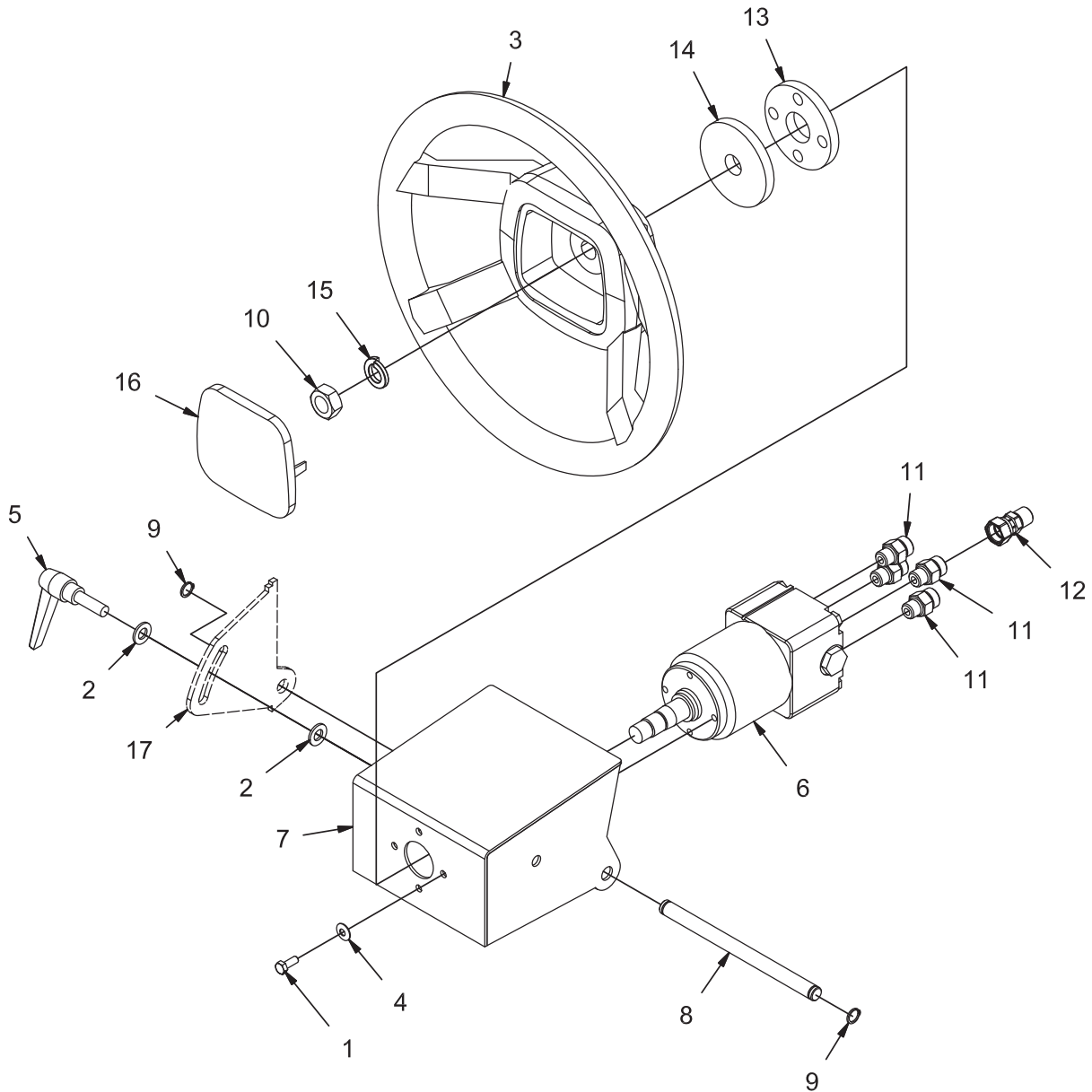

REV C

STEERING COLUMN GROUP (730104)

Parts List			
ITEM	PART NUMBER	QTY	DESCRIPTION
1	11038072	4	BOLT, M6-1.00 X 16 HH
2	12310058	2	WASHER, M10
3	3338215	1	STEERING WHEEL
4	3400383	4	WASHER, 1/4 BELLEVILLE
5	600260	1	KNOB, LEVER
6	600368	1	STEERING UNIT
7	600465	1	WELDMENT, STEERING MNT
8	600516	1	SHAFT, ROLLER
9	600569	2	RETAINING RING, EXT .50 HD
10	620057	1	NUT, JAM, M16-1.50 STL ZP
11	675515	4	FITTING, STR, 6 ORFS - 6 SAE
12	675636	1	FTG-ORFS ORIFICE .078 #6
13	690152	1	DUST RING, STEERING
14	690160	1	DUST RING, STEERING, UPPER
15	712315	1	WSR-HELI .64 X 1.26 X .06 PL
16	PART OF 3338215	1	COVER, STEERING WHEEL
17	REF	1	FRAME

INSTRUMENT PANEL GROUP - DIESEL (730108)

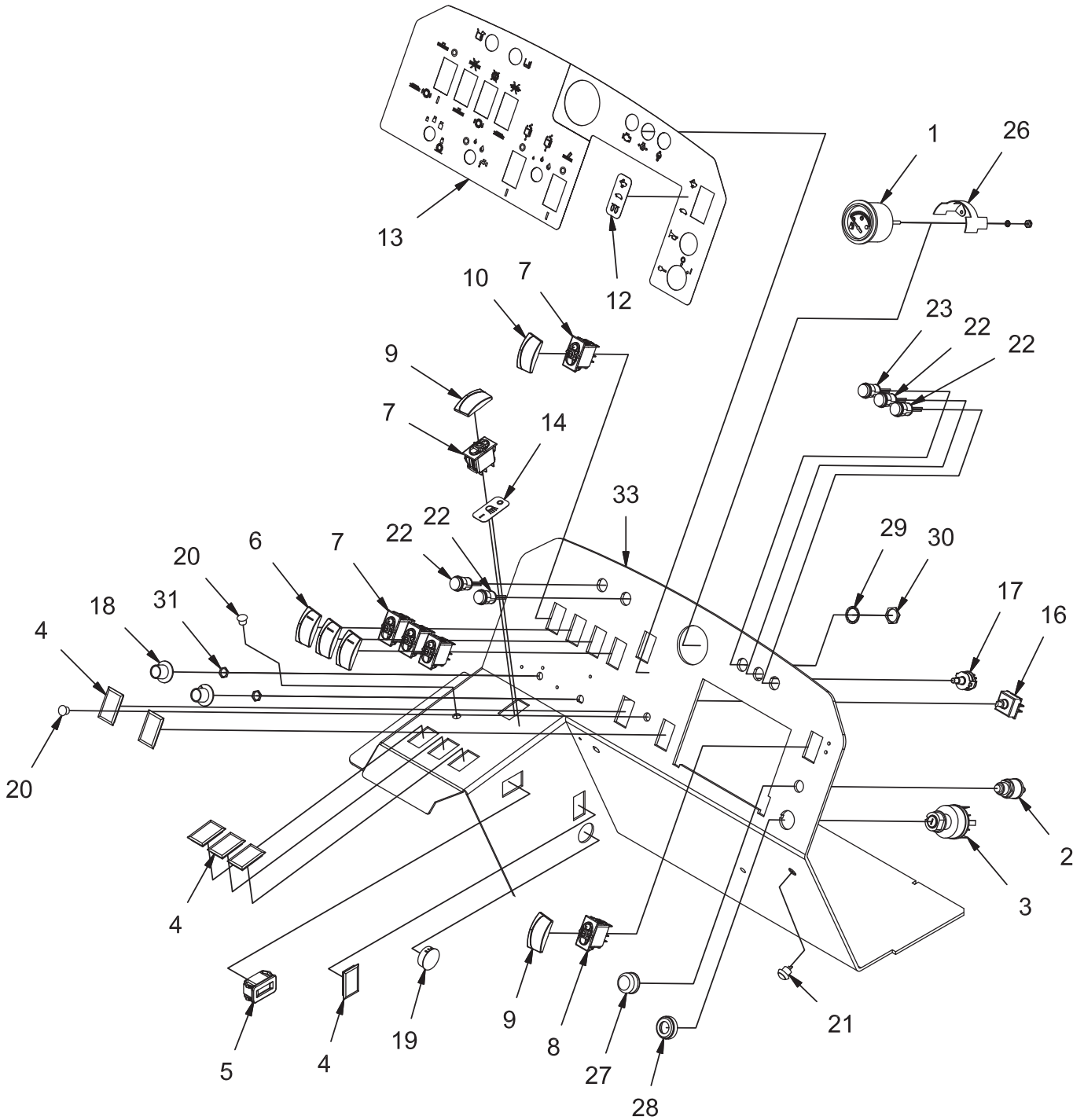

REV H

INSTRUMENT PANEL GROUP - DIESEL (730108)

Parts List 730108			
ITEM	PART NUMBER	QTY	DESCRIPTION
1	3300382	1	GAUGE, FUEL
2	3300441	1	SWITCH, MOMENTARY
3	3316100	1	KEYSWITCH
4	3323529	6	COVER
5	3336094	1	HOUR METER
6	3342273	3	SWITCH COVER - BLACK, CLEAR LENS
7	3342705	5	SWITCH, DPST
8	3343912	1	SWITCH, DPDT
9	3344038	2	SWITCH CAP
10	3344039	1	SWITCH CAP. GREEN
12	715956	1	DECAL, DIESEL IGN
13	715957	1	DECAL, INST PANEL
14	715973	1	DECAL, LIGHTS
16	730850	1	SWITCH, ROTARY, 3-WAY
17	730989-1	1	SWITCH, ROTARY 3-POS
18	731187	2	KNOB
19	731393	1	HOLE PLUG, 1-1/8
20	742749	2	PLUG, BLACK PLASTIC
21	748791-1	1	SWITCH, MOMENTARY
22	748995	4	LIGHT ASSY, INDICATOR RED - LED
23	748996	1	LIGHT ASSY, INDICATOR AMBER - LED
24	748998	1	HARNESS, FUEL GAUGE
26	PART OF 3300382	1	RETAINER, GAUGE
27	PART OF 3300441	1	CAP, SWITCH
28	PART OF 3316100	1	NUT, KEYSWITCH
29	PART OF LED	5	LOCKWASHER
30	PART OF LED	5	NUT
31	PART OF ROTARY SWITCH	2	NUT
33	REF	-	CONSOLE
-	3301345-1	1	WIRE ASSY, LIGHT GAUGE

INSTRUMENT PANEL GROUP - GAS (730107)

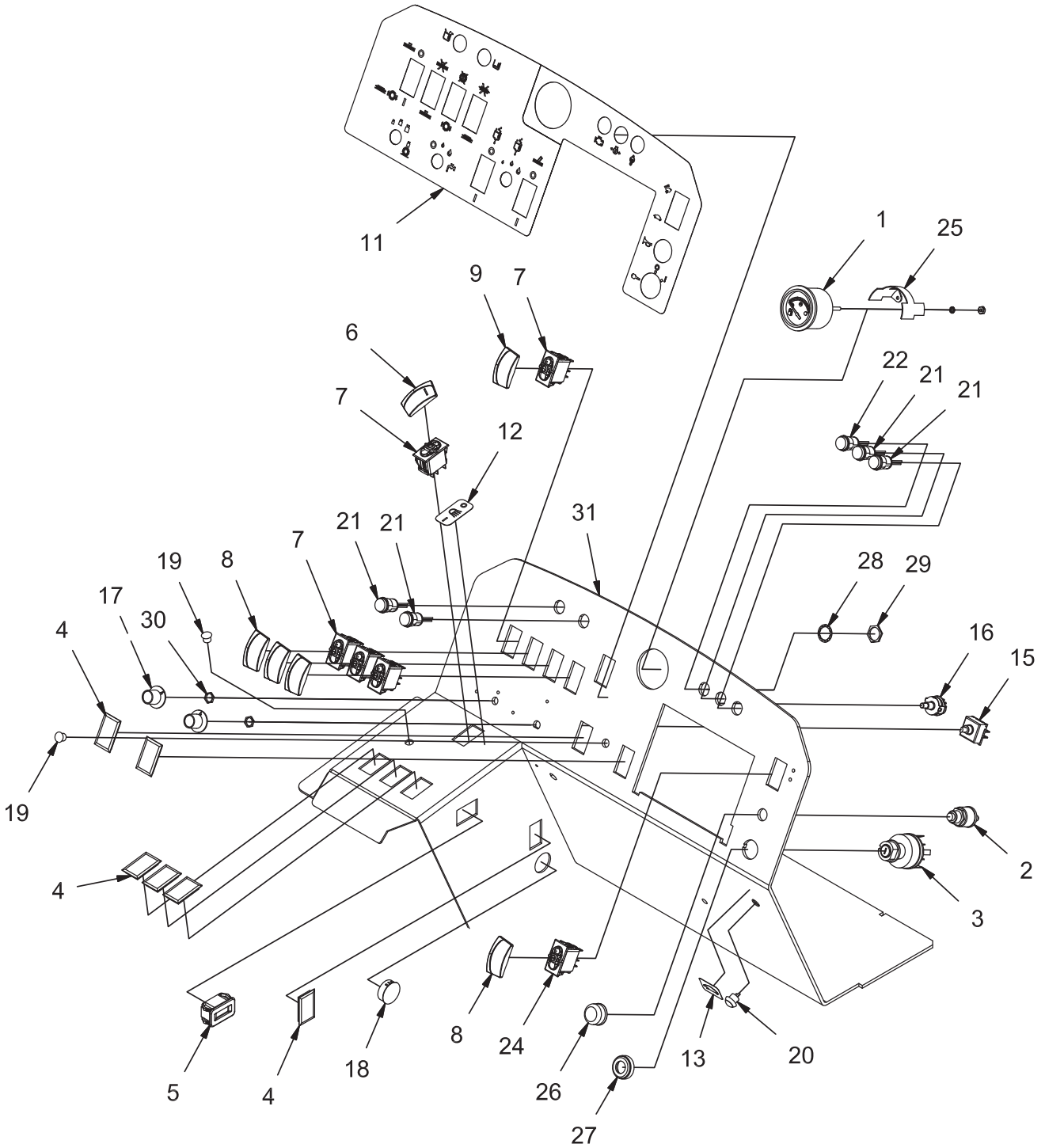

REV K

INSTRUMENT PANEL GROUP - GAS (730107)

Parts List 730107			
ITEM	PART NUMBER	QTY	DESCRIPTION
1	3300382	1	GAUGE, FUEL
2	3300441	1	SWITCH, MOMENTARY
3	3316100	1	KEYSWITCH
4	3323529	6	COVER
5	3336094	1	HOUR METER
6	3342273	1	SWITCH COVER - BLACK, CLEAR LENS
7	3342705	5	SWITCH, DPST
8	3344038	4	SWITCH CAP
9	3344039	1	SWITCH CAP. GREEN
11	715957	1	DECAL, INST PANEL
12	715973	1	DECAL, LIGHTS
13	715974	1	DECAL, IDLE
15	730850	1	SWITCH, ROTARY, 3-WAY
16	730989-1	1	SWITCH, ROTARY 3-POS
17	731187	2	KNOB
18	731393	1	HOLE PLUG, 1-1/8
19	742749	2	PLUG, BLACK PLASTIC
20	748791-1	1	SWITCH, MOMENTARY
21	748995	4	LIGHT ASSY, INDICATOR RED - LED
22	748996	1	LIGHT ASSY, INDICATOR AMBER - LED
23	748998	1	HARNESS, FUEL GAUGE
24	3342703	1	SWITCH, DPDT
25	PART OF 3300382	1	RETAINER, GAUGE
26	PART OF 3300441	1	CAP, SWITCH
27	PART OF 3316100	1	NUT, KEYSWITCH
28	PART OF LED	5	LOCKWASHER
29	PART OF LED	5	NUT
30	PART OF ROTARY SWITCH	2	NUT
31	REF	-	CONSOLE
-	3301345-1	1	WIRE ASSY, LIGHT GAUGE

INSTRUMENT PANEL GROUP - LPG (730106)

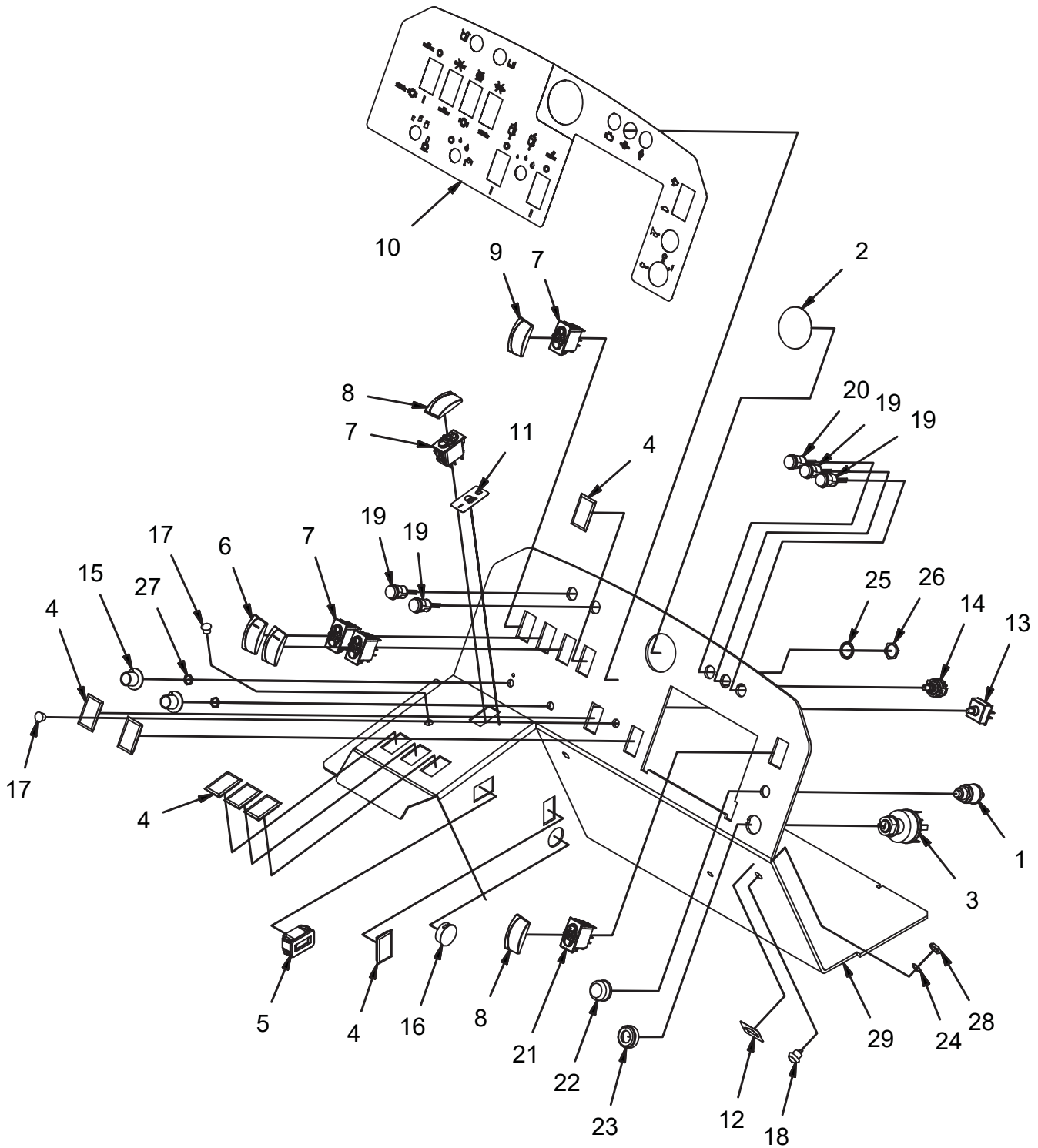

REV F

INSTRUMENT PANEL GROUP - LPG (730106)

Parts List 730106			
ITEM	PART NUMBER	QTY	DESCRIPTION
1	3300441	1	SWITCH, MOMENTARY
2	3301822	1	PLUG, PLASTIC, 2.00
3	3316100	1	KEYSWITCH
4	3323529	7	COVER
5	3336094	1	HOUR METER
6	3342273	2	SWITCH COVER - BLACK, CLEAR LENS
7	3342705	4	SWITCH, DPST
8	3344038	2	SWITCH CAP
9	3344039	1	SWITCH CAP. GREEN
10	715957	1	DECAL, INST PANEL
11	715973	1	DECAL, LIGHTS
12	715974	1	DECAL, IDLE
13	730850	1	SWITCH, ROTARY, 3-WAY
14	730989-1	1	SWITCH, ROTARY 3-POS
15	731187	2	KNOB
16	731393	1	HOLE PLUG, 1-1/8
17	742749	2	PLUG, BLACK PLASTIC
18	748791-1	1	WIRE ASSY, SWITCH
19	748995	4	LIGHT ASSY, INDICATOR RED - LED
20	748996	1	LIGHT ASSY, INDICATOR AMBER - LED
21	3342703	1	SWITCH, DPDT
22	PART OF 3300441	1	CAP, SWITCH
23	PART OF 3316100	1	NUT, KEYSWITCH
24	PART OF 748791-1	1	WASHER
25	PART OF LED	5	LOCK WASHER
26	PART OF LED	5	NUT
27	PART OF ROTARY SWITCH	2	NUT
28	PART OF 748791-1	1	NUT
29	REF	-	CONSOLE

INSTRUMENTATION GROUP (730109)

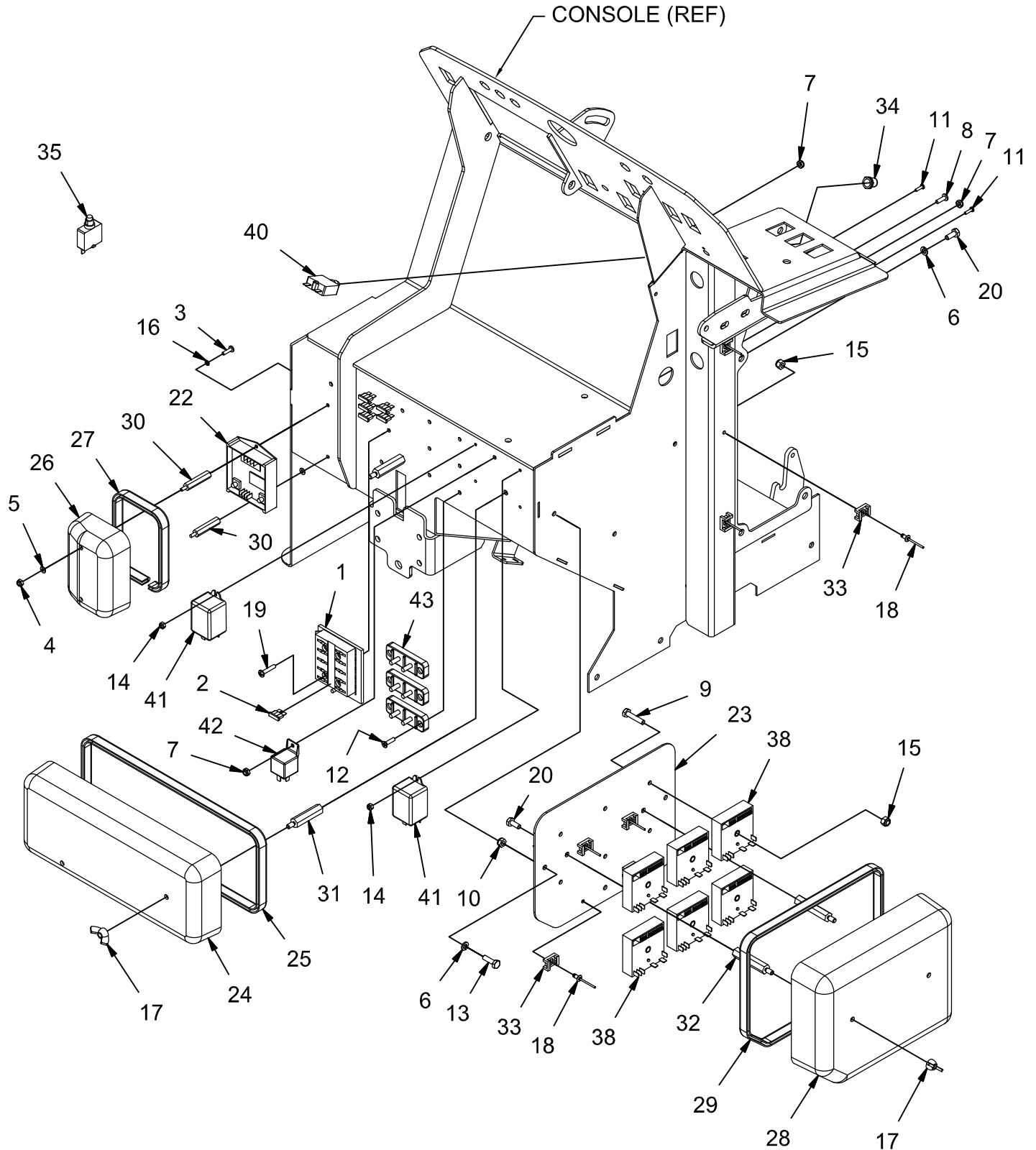

REV F

INSTRUMENTATION GROUP (730109)

Parts List - INSTRUMENTATION GROUP			
ITEM	PART NUMBER	QTY	DESCRIPTION
1	3322599	1	FUSE BLOCK
2	3322601	6	FUSE, 15A
3	3400045	2	SCREW, #8-32 X .625 PAN HD ZP
4	3400082	2	NUT, FIBER INSERT #8-32
5	3400096	2	FLATWASHER, #8
6	3400103	5	LOCK WASHER, 1/4 HS MED
7	3400172	9	NUT, 10-32 ESN
8	3400204	1	SCREW, #10-32 X .625 PAN HD ZP
9	3400227	6	SCREW, 1/4-20 X 1.25 HH ZP
10	3401021	3	NUT, LOW HEIGHT 1/4-20 ESN
11	710204	4	SCREW, #6-32 X .500 PAN HD ZP
12	710556	6	SCREW, FHMS, 10-32 X .75 ZP
13	711206	3	BLT - HH 1/4-20 X .87 STL ZINC
14	711371	4	NUT, #6-32 ESN ZP
15	711373	9	NUT, FIBER INSERT 1/4-20
16	711542	2	WASHER, HELICAL, #8 ZP
17	711563	4	WING NUT, 1/4-20, NYLON
18	711903	7	RIVET, BLIND, .19 D X .126 - .250 GRIP ALU
19	712546	2	SCREW, #10-32 X 1.00 PAN HD ZP
20	713001	4	SCREW, 1/4-20 X .625 HHC
21	731125	-	PROP VALVE DRIVER (PART OF 731125-1)
22	731125-1	1	ASSEMBLY, PROPORTIONAL VALVE DRIVER
23	731191	1	PLATE, TIMER
24	731227	1	COVER, FUSE PANEL
25	731228	1	SEAL, FUSE COVER
26	731229	1	COVER, CONTROLLER
27	731230	1	SEAL, CONTROLLER
28	731231	1	COVER, TIMER
29	731232	1	SEAL, TIMER COVER
30	731233	2	STANDOFF, PANEL, #8-32 X 1.75
31	731234	2	STANDOFF, PANEL, 1/4-20 X 2.00
32	731236	2	STANDOFF, PANEL, 1/4-20 X 2.38
33	731258	7	MOUNT, CABLE TIE
34	742748	1	BOOT, CIRCUIT BREAKER
35	746006	1	CIRCUIT BREAKER, 3A (ATTACHED TO HARNESS)
36	748339	-	HANESS, WIRE ASSY (PART OF 748430-1)
37	748430	-	TIMER (PART OF 748430-1)
38	748430-1	6	ASSEMBLY, TIMER
39	748431	-	HARNESS, WIRE ASSY (PART OF 731125-1)
40	748904	1	CIRCUIT BREAKER, 40A
41	748961	2	RELAY, DPDT, 12VDC, 35A
42	90264672	1	RELAY, SPDT, 12VDC, 30A
43	90286238	3	TERMINAL BLOCK

ELECTRICAL BOX GROUP - DIESEL (730156)

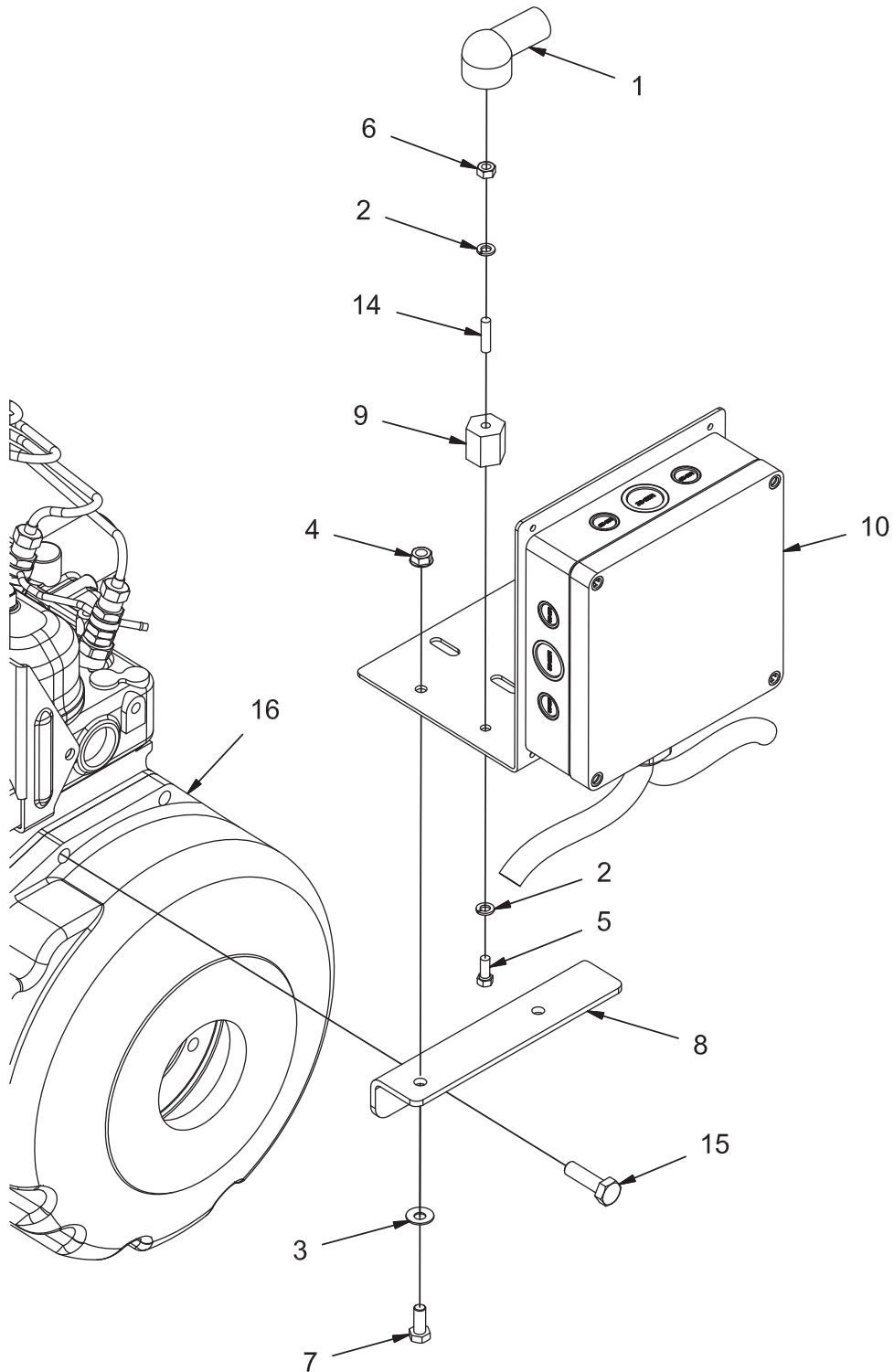

REV D

ELECTRICAL BOX GROUP - DIESEL (730156)

Parts List - 730156			
ITEM	PART NUMBER	QTY	DESCRIPTION
1	3342931	1	BOOT
2	3400103	2	LOCK WASHER, 1/4 HS MED
3	3400384	2	WASHER, 5/16 BELLEVILLE
4	600934	2	NUT, M8-1.25 FLNG
5	711203	1	BOLT, 1/4-20 X .625
6	711316	1	NUT, HEX 1/4-20 ZINC PL
7	717024	2	BOLT, M8-1.25 X 20 HH
8	730532	1	ANGLE, MOUNT
9	740132	1	PLASTIC INSULATOR
10	748769	1	DIESEL CONTROL BOX ASSEMBLY
11	749056	1	HARNESS ASSY, ECU POWER <i>(NOT SHOWN)</i>
12	748950	1	WIRE ASSY, OIL PRESS. SWTCH <i>(NOT SHOWN)</i>
13	748951	1	WIRE ASSY, WTR TEMP SWTCH <i>(NOT SHOWN)</i>
14	833638	1	1/4-20 STUD, BRASS
15	REF.	-	BOLT
16	REF.	-	DIESEL ENGINE

DIRECTIONAL CONTROL GROUP (730110)

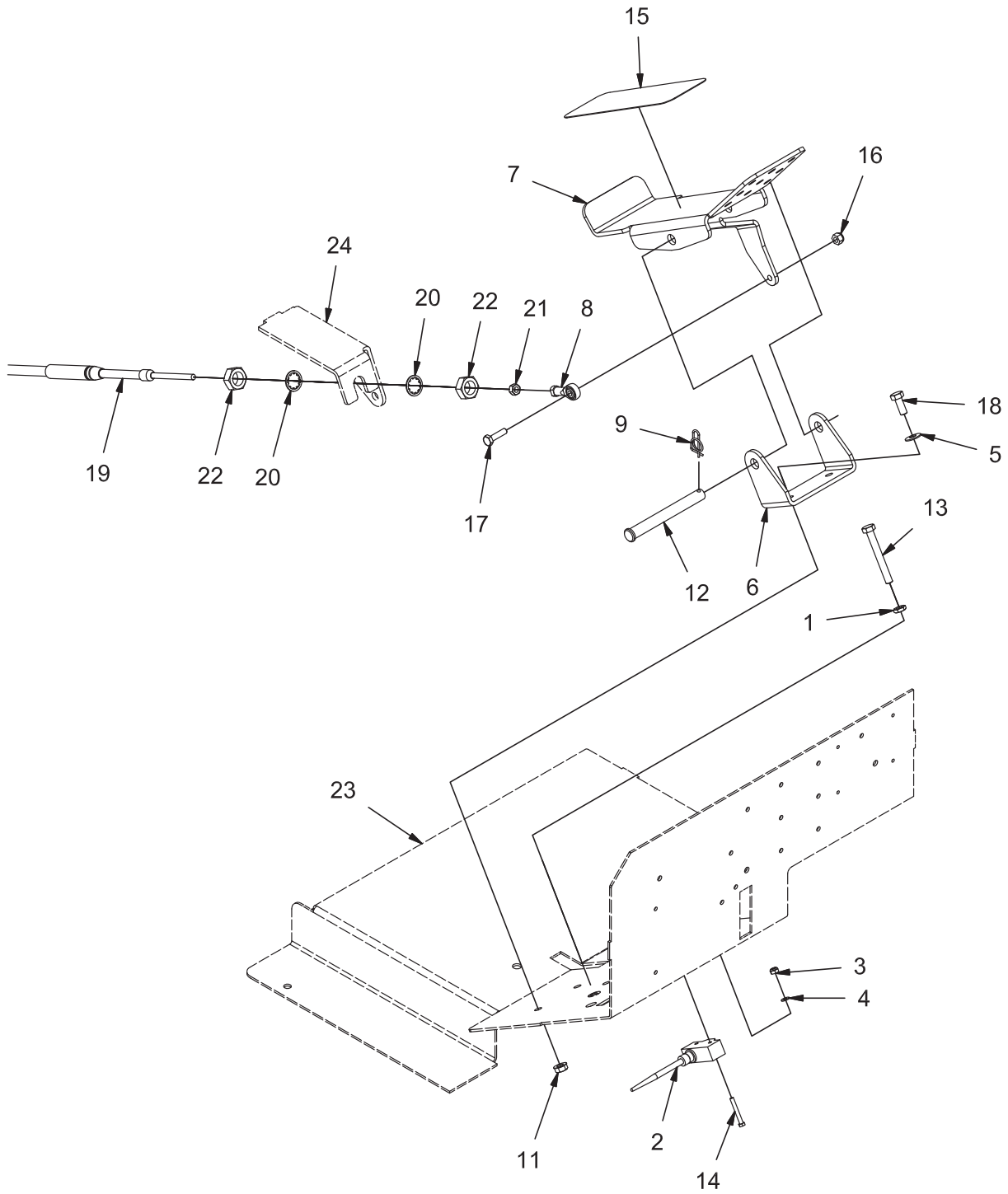

REV D

DIRECTIONAL CONTROL GROUP (730110)

Parts List 730110			
ITEM	PART NUMBER	QTY	DESCRIPTION
1	12012019	1	NUT, M8-1.25 JAM
2	3342546-1	1	HARNESS, SWITCH, WHISKER
3	3400082	2	NUT, FIBER INSERT #8-32
4	3400096	2	FLATWASHER, #8
5	3400384	2	WASHER, 5/16 BELLEVILLE
6	600134	1	BRACKET, F/R PEDAL
7	600135	1	PEDAL, F/R
8	600175	1	ROD END, FEM 1/4-28
9	600578	1	RUE-RING, .50
10	600851	1	M8-1.25 INSERT, .125 GRIP
11	600934	2	NUT, M8-1.25 FLNG
12	620027	1	PIN, CLEVIS 1/2 X 4.50
13	620033	1	BOLT, M8-1.25 X 65 HH
14	620136	2	BOLT, #8-32 X 1.25 HH ZP
15	620179	1	PAD, F/R PEDAL
16	711373	1	NUT, FIBER INSERT 1/4-20
17	713003	1	SCREW, 1/4-20 X 1.00 HH
18	717024	2	BOLT, M8-1.25 X 20 HH
19	730356	1	CABLE, JACKETED, 92.50 OAL
20	PART OF 730356	2	LOCK WASHER
21	PART OF 730356	1	NUT, 1/4-28
22	PART OF 730356	2	NUT, 5/8-18 JAM
23	REF	-	CONSOLE
24	REF.	-	FRAME

PUMP LINKAGE GROUP (730111)

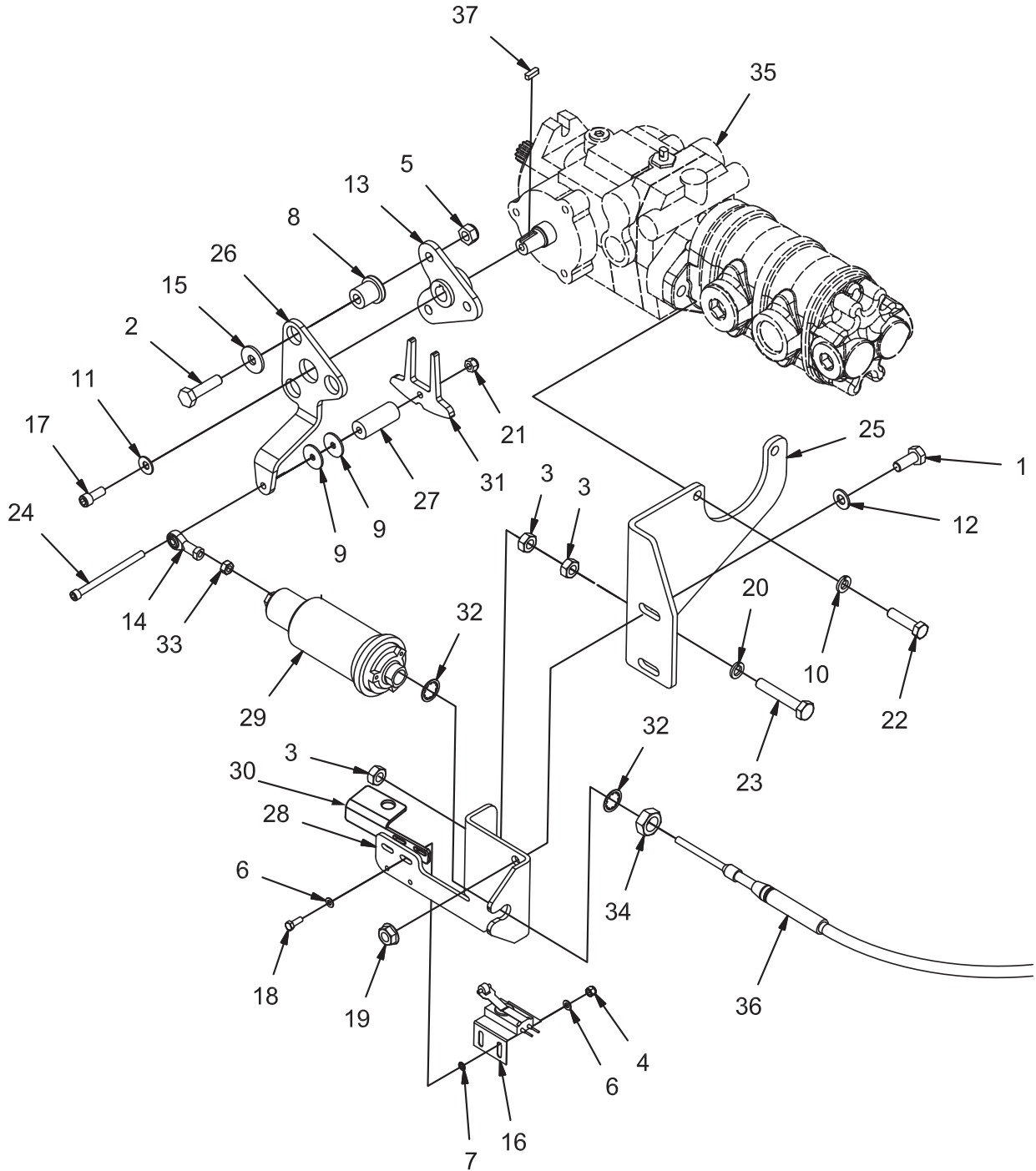

REV F

PUMP LINKAGE GROUP (730111)

Parts List 730111			
ITEM	PART NUMBER	QTY	DESCRIPTION
1	11038346	2	BOLT, M10-1.50 X 25 HH
2	11038395	3	BOLT, M10-1.50 X 40 HH
3	12022067	3	NUT, M10-1.50 HEX
4	711350	2	NUT-NYLOC 10-32 ZP
5	12040069	3	NUT, M10-1.50 ESN
6	711503	4	WASHER-FLAT #10 X .50 ZP
7	12518080	2	WASHER, STAR, M5, INT. ZP
8	3300465	3	ISOLATOR, VIB
9	3400090	2	WASHER, FENDER, 1/4 ZP
10	3400101	2	LOCK WASHER, 3/8 HS MED
11	3400384	1	WASHER, 5/16 BELLEVILLE
12	3400385	2	WASHER, 3/8, BELLEVILLE
13	600141	1	WELDMENT, DIR CONT HUB
14	600175	1	ROD END, FEM 1/4-28
15	600363	3	WASHER, ISOLATOR
16	749009	1	SWITCH ASSY, ROLLER PLUNGER
17	600895	1	BOLT, 5/16-24 X .75 SHCS
18	3400044	2	SCR-HH 10-32 X .75 ZP SERR FLANGE
19	600936	2	NUT, M10-1.50 FLNG
20	600945	1	LOCK WASHER, M10
21	711373	1	NUT, FIBER INSERT 1/4-20
22	713044	2	SCREW, 3/8-16 X 1.50 HHC
23	730481	1	BOLT, M10-1.50 X 60 HH ALL-THRD
24	730699	1	BOLT, 1/4-20 X 3.50 SOC HD CAP
25	730714	1	MOUNT, HYDROBACK
26	730715	1	ARM, DIR CONT
27	731108	1	SPACER, .266 B .750 OD 1.81 T
28	731109	1	ADJUSTER, HYDROBACK W/SW MNT
29	731181	1	HYDROBACK CENTERING UNIT, 10 LB
30	731394	1	BRACKET, NEUTRAL SWITCH
31	731395	1	CAM, NEUTRAL, NAUTILUS
32	PART OF CABLE ASSY	2	LOCK WASHER
33	PART OF CABLE ASSY	1	NUT, 1/4-28
34	PART OF CABLE ASSY	1	NUT, 5/8-18 JAM
35	REF.	-	PUMP, PROPULSION
36	REF.	-	CABLE, PUSH-PULL
37	WITH PUMP	1	KEY

SCRUB HEAD GROUP (730112)

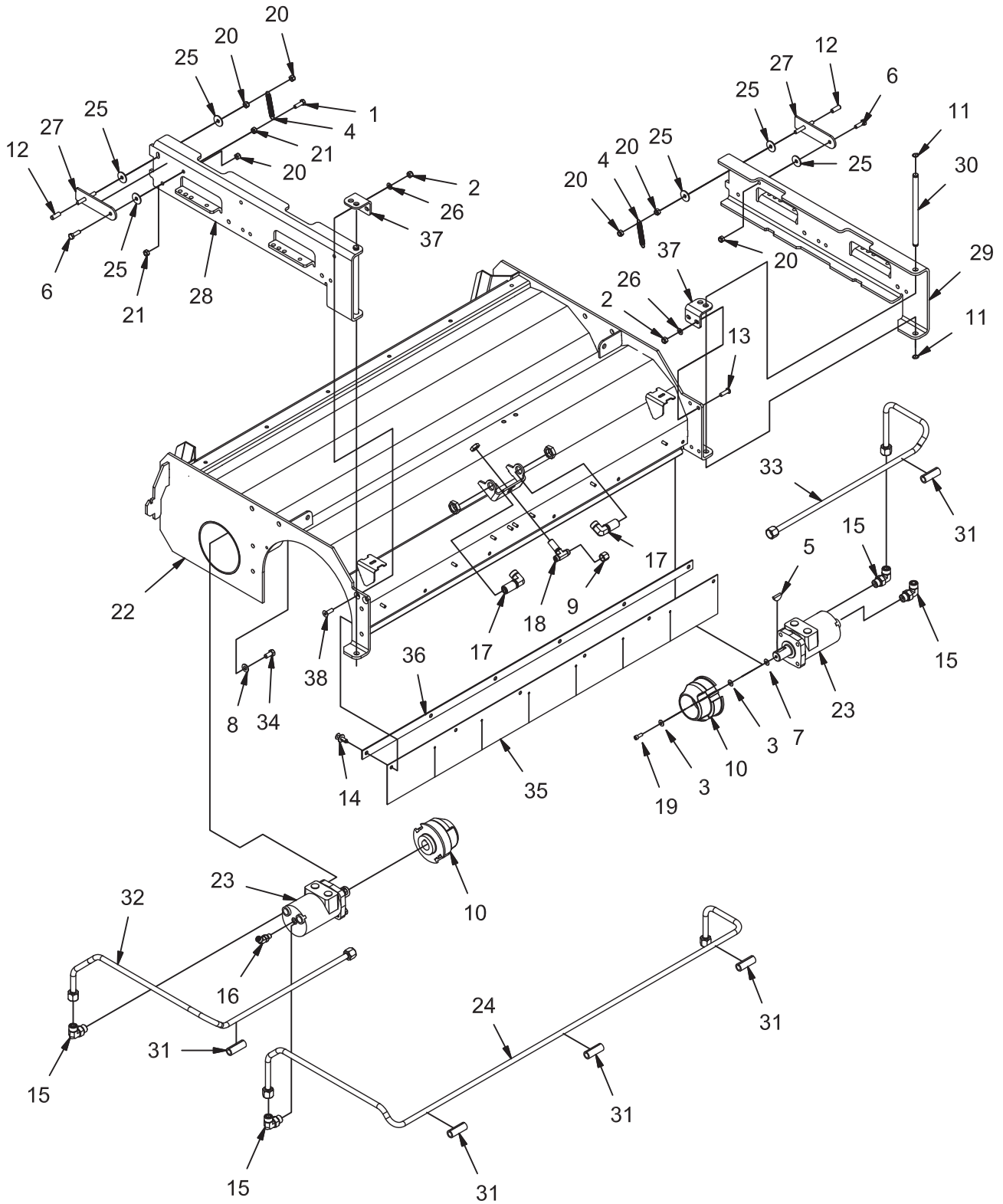

REV H

SCRUB HEAD GROUP (730112)

Parts List 730112			
ITEM	PART NUMBER	QTY	DESCRIPTION
1	11039567	1	BOLT, M8-1.25 X 25 HH SS
2	12040259	4	NUT, M8-1.25 ESN SS
3	712761	4	WASHER-FENDER 1/4 X 1.25 X .059 SS
4	3304160	2	SPRING, EXT
5	3330338	2	KEY, WOODRUFF .25 X .50
6	3400318	2	BOLT, 5/16-18 X 1.00 HH SS
7	3400383	2	WASHER, 1/4 BELLEVILLE
8	3400385	8	WASHER, 3/8, BELLEVILLE
9	675605	1	FITTING, CAP -4 ORFS
10	731304-1	2	HUB, MAIN BROOM DRIVE <i>ORDER K-731304-1 KIT</i>
11	600569	4	RETAINING RING, EXT .50 HD
12	600910	2	CAP
13	600917	2	SCREW, M8-1.25 X 25 BUTTON HD CAP SS
14	600965	6	FASTENER, PRESS-IN
15	675523	4	FITTING, 90, -8 ORFS - 8 SAE
16	675541	1	FITTING, 45, 4 ORFS - 4 SAE
17	675544	2	FITTING, 90, BULKHEAD 8 ORFS - 8 ORFS
18	675607	1	FITTING, BULKHEAD TEE - 4 ORFS - 4 ORFS
19	712562	2	SCR-HH 1/4-20 X .75, 18-8 SS
20	712683	6	NUT, 5/16-18 ESN SS
21	717029	2	NUT, M8-1.25 SS
22	730325MBC	1	WELDMENT, SCRUB HEAD
23	730343	2	MOTOR, 4.5 DISP
24	730348	1	ASSEMBLY, CROSS TUBE
25	730526	6	WASHER, M8 FENDER SS
26	730609	4	WASHER, M8 SS
27	730622	2	WELDMENT, DOOR LATCH
28	730626	1	SQU MNT CHANNEL, RH
29	730627	1	SQU MNT CHANNEL, LH
30	730642	2	SHAFT, .50 D X 8.00 L
31	730685	5	GUARD, HOSE
32	730775	1	ASSEMBLY, RH MOTOR TUBE
33	730776	1	ASSEMBLY, LH MOTOR TUBE
34	730959	8	SCREW, 3/8-16 X .750 HHC SS
35	730982	1	SKIRT, SCRUB HEAD
36	730983	1	STRAP, RETAINER
37	731131	2	HINGE, ADJ
38	731139	2	SCREW, M8-1.25 X 25 FHCS SS

SCRUB BRUSH LIFT GROUP (730113)

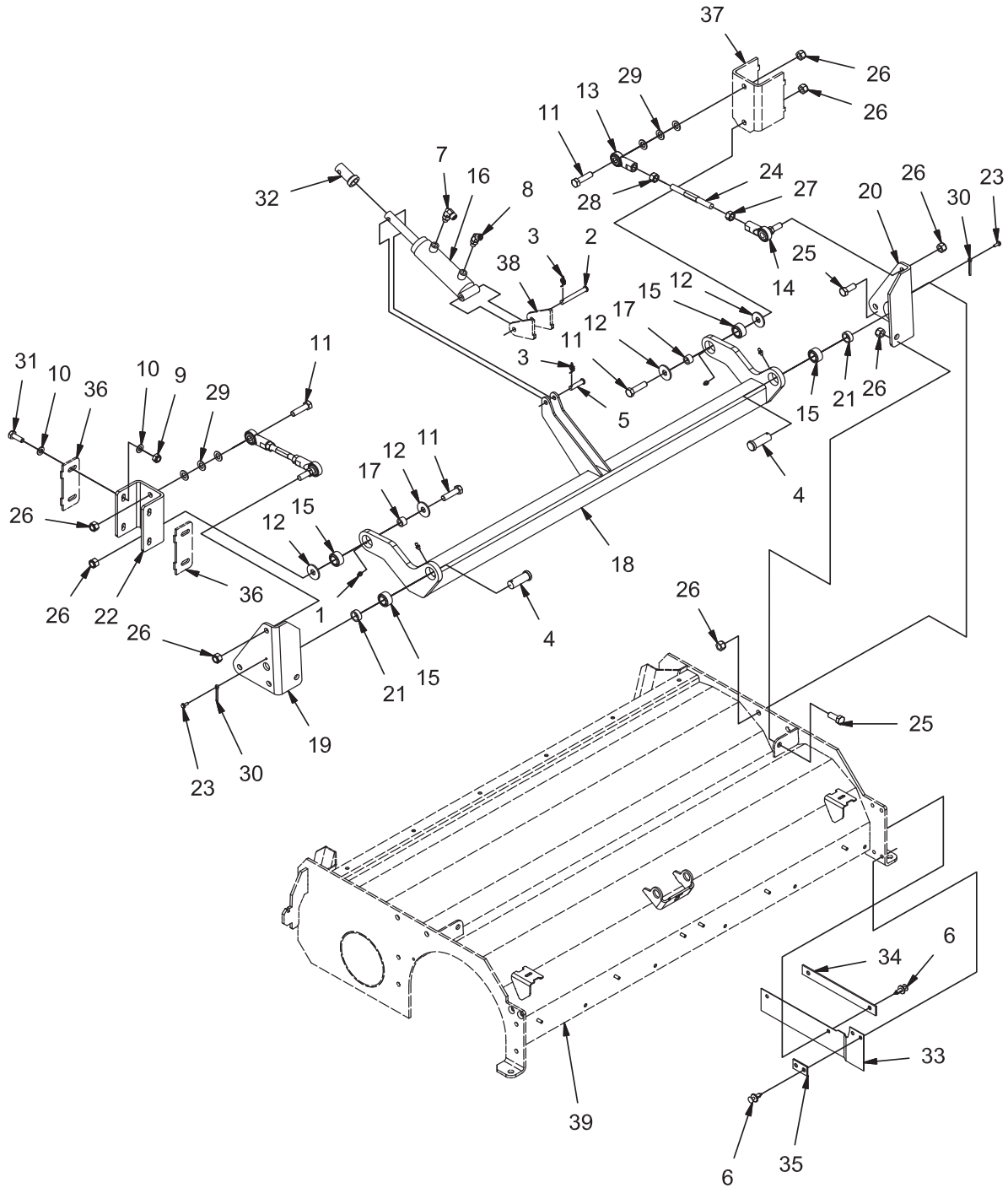

REV C

SCRUB BRUSH LIFT GROUP (730113)

Parts List 730113			
ITEM	PART NUMBER	QTY	DESCRIPTION
1	710006	4	GREASE ZIRK
2	3400115	1	PIN, CLEVIS, .375 X 3.00
3	3400125	2	RUE-RING, .375
4	3400439	2	CLEVIS PIN, .75 X 2.00
5	600573	1	PIN, CLEVIS, 3/8 X 1.50
6	600965	4	FASTENER, PRESS-IN
7	675507	1	FITTING, 90, -4 ORFS - 4 SAE
8	675541	1	FITTING, 45, 4 ORFS - 4 SAE
9	730339	4	NUT, M10-1.50 ESN SS
10	730344	8	WASHER, M10 SS
11	730516	4	BOLT, M12-1.75 X 45 HH SS
12	730528	4	WASHER, .512 B 1.46 OD .118 T SS
13	730544	2	ROD END, FEM, M12-1.75
14	730545	2	ROD END, FEM, M12-1.75 LH THRD W/STUD
15	730547	4	BEARING, SPHERICAL
16	730548	1	CYLINDER, HYD, 1.5 B X 2.88 STK
17	730549	2	SPACER, .484 B .746 OD .500 T
18	730590	1	WELDMENT, SH LIFT ARM
19	730594	1	WELDMENT, SH LIFT BRACKET RH
20	730597	1	WELDMENT, SH LIFT BRACKET, LH
21	730599	2	SPACER, .760 B 1.00 OD .375 T
22	730600	1	CHANNEL, SH ADJ MNT
23	730601	2	SCREW, #10-32 x .50 SELF TAPPING SS
24	730603	2	ROD, ADJ
25	730604	6	BOLT, M12-1.75 X 30 HH SS
26	730605	12	NUT, M12-1.75 ESN SS
27	730606	2	NUT, M12-1.75 LH THRD SS
28	730607	2	NUT, M12-1.75 HEX SS
29	730608	6	WASHER, M12 SS
30	730610	2	PIN, COTTER, .156 X 1.25 SS
31	730878	4	BOLT, M10-1.50 X 30 HH SS
32	731194	1	TUBE, STOP
33	731362	1	SKIRT, SIDE
34	731363	1	SKIRT RETAINER, REAR
35	731364	1	SKIRT RETAINER, FRONT
36	REF.	-	FRAME
37	REF.	-	FRAME
38	REF.	-	FRAME
39	REF.	-	SCRUB HEAD

SCRUB BRUSH IDLER GROUP (730114)

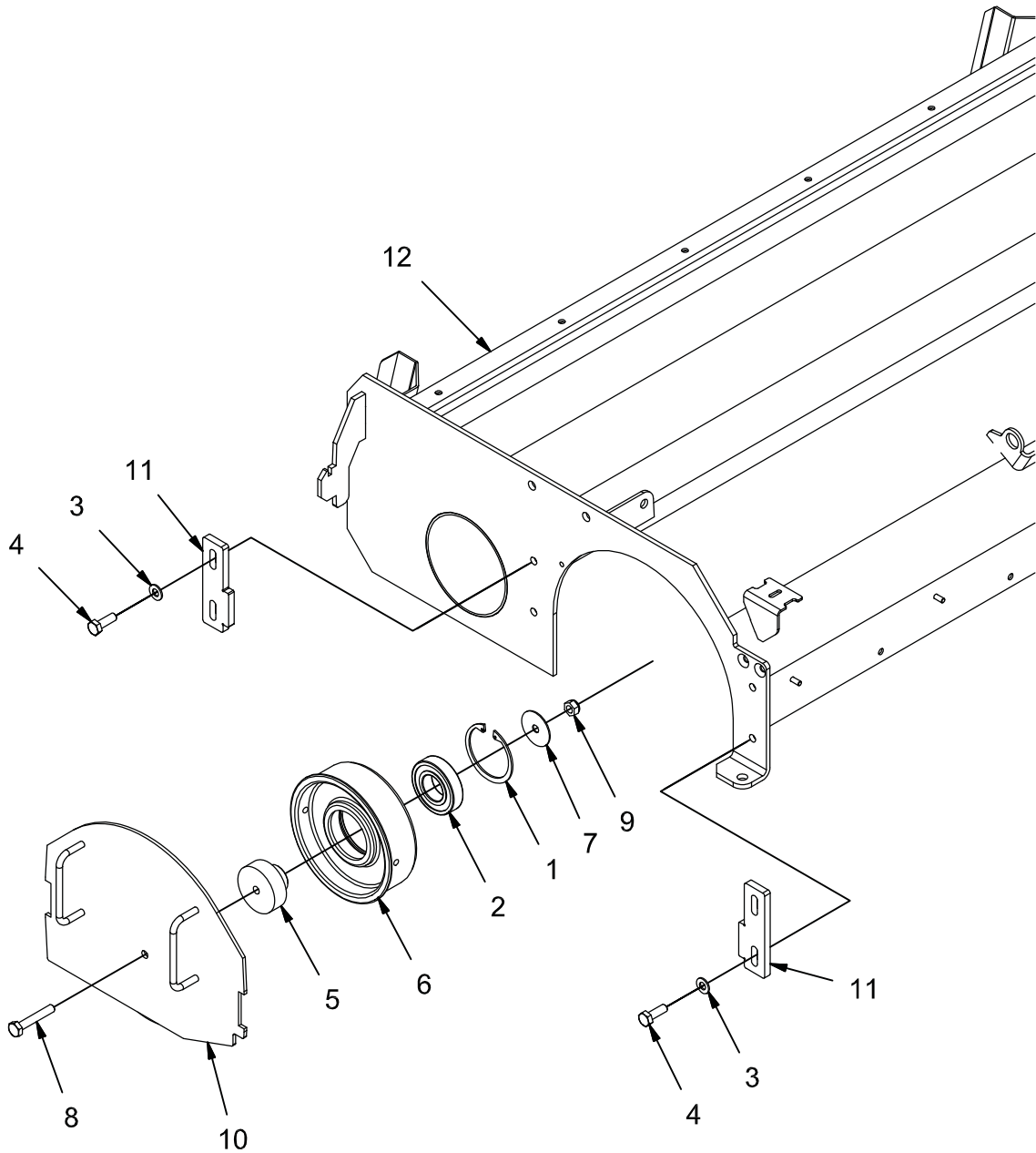

REV C

SCRUB BRUSH IDLER GROUP (730114)

Parts List 730114			
ITEM	PART NUMBER	QTY	DESCRIPTION
1	3305666	2	RING, RETAINING, INT
2	3305667	2	BEARING, BALL, 207PP
3	3400385	8	WASHER, 3/8, BELLEVILLE
4	730878	8	BOLT, M10-1.50 X 30 HH SS
5	600544	2	MOUNT, BEARING
6	620083	2	IDLER, MAIN BROOM
7	712768	2	WSR-FLT .406 X 1.875 SS
8	730323	2	BOLT, M10-1.50 X 60 HH SS
9	730339	2	NUT, M10-1.50 ESN SS
10	730341	2	WELDMENT, BRUSH RETAINER
11	730613	4	PLT, ADJ
12	REF.	-	SCRUB HEAD

BRUSH DOOR GROUP (730115)

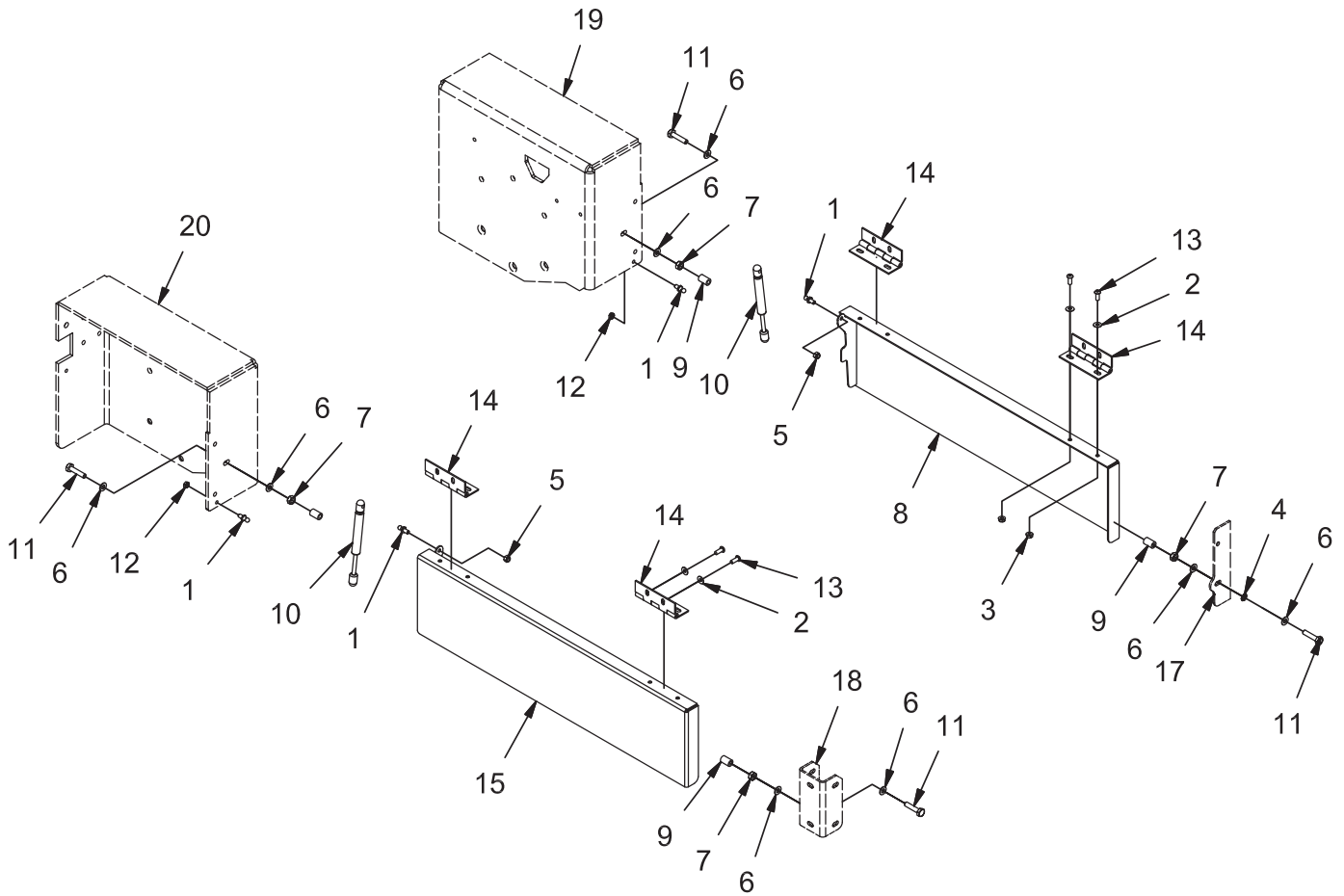

REV C

BRUSH DOOR GROUP (730115)

Parts List 730115			
ITEM	PART NUMBER	QTY	DESCRIPTION
1	3300376	4	STUD, 10MM BALL
2	3400384	16	WASHER, 5/16 BELLEVILLE
3	600934	8	NUT, M8-1.25 FLNG
4	600946	1	LOCK WASHER, 3/8 INT STAR
5	712683	2	NUT, 5/16-18 ESN SS
6	730344	8	WASHER, M10 SS
7	730718	4	NUT, M10-1.50 HEX SS
8	730900	1	WELDMENT, LH BRUSH DOOR
9	730901	4	TUBING, STOP
10	730902	2	GAS STRUT, 8.77 EXT, 3.00 STK, 200N
11	730903	4	BOLT, M10-1.50 X 45 HH SS
12	730904	2	NUT, 5/16-18 HEX JAM SS
13	730905	16	SCREW, M8-1.25 X 20 BUTTON HD CAP SS
14	730906	4	HINGE, 5"
15	730952	1	WELDMENT, SSB DOOR
17	REF.	-	FRAME
18	REF.	-	FRAME
19	REF.	-	FRAME
20	REF.	-	FRAME

SQUEEGEE LIFT GROUP (730119)

Parts List 730119			
ITEM	PART NUMBER	QTY	DESCRIPTION
1	11039328	4	BOLT, M10-1.50 X 25 HH SS
2	11039567	2	BOLT, M8-1.25 X 25 HH SS
3	3304624	1	CAP, RUBBER BUMPER
4	3400125	1	RUE-RING, .375
5	3400178	2	WASHER, THRUST, .53 B 1.00 OD .03 T
6	3400355	1	SCR, LEVEL BOLT, 3/8-16 X 2.50
7	3400384	2	WASHER, 5/16 BELLEVILLE
8	450034	1	PIN, CLEVIS, .313 X .75
9	600106	1	CYLINDER
10	600220	2	BUMPER, 1.00 X .625 T
11	600569	1	RETAINING RING, EXT .50 HD
12	600578	2	RUE-RING, .50
13	620143	1	COTTERPIN, 5/64 X 1/2
14	675507	2	FITTING, 90, -4 ORFS - 4 SAE
15	712098	1	PIN, CLEVIS 1/2 X 3.50
16	712680	2	NUT, HEX 5/16-18 SS
17	712695	1	NUT, HEX 3/8-16 SS
18	730339	4	NUT, M10-1.50 ESN SS
19	730527	2	LOCK WASHER, M8, SS
20	730528	1	WASHER, .512 B 1.46 OD .118 T SS
21	730605	1	NUT, M12-1.75 ESN SS
22	730647	2	WASHER, THRUST, .66 B 1.25 OD .06 T
23	730724	1	WELDMENT, SQU LIFT
24	730738	1	WELDMENT, SQU LIFT ARM
25	730741	1	PIN, SQU LIFT
26	730745	1	PULLEY
27	730746	1	CABLE ASSEMBLY
28	730747	1	BEARING, DU .625 ID .25 L
29	730749	1	SPACER, .484 B .622 OD .390 T
30	730750	2	BUSHING, BRONZE, FLANGED. .50 B .62 OD .31 T
31	730752	1	FIBERGLIDE BEARING, .500 ID .750 T
32	730756	1	NUT, 1/2-13 ESN, SS
33	730757	2	NUT, 3/8-24 JAM ESN SS
34	730759	1	WASHER, 1/2, SS
35	730760	1	PIN, CLEVIS 1/2 X 2.75
36	730761	1	PIN, CLEVIS, .25 X .275
37	730762	1	BOLT, M12-1.75 X 35 HH SS

SQUEEGEE LINKAGE GROUP (730158)

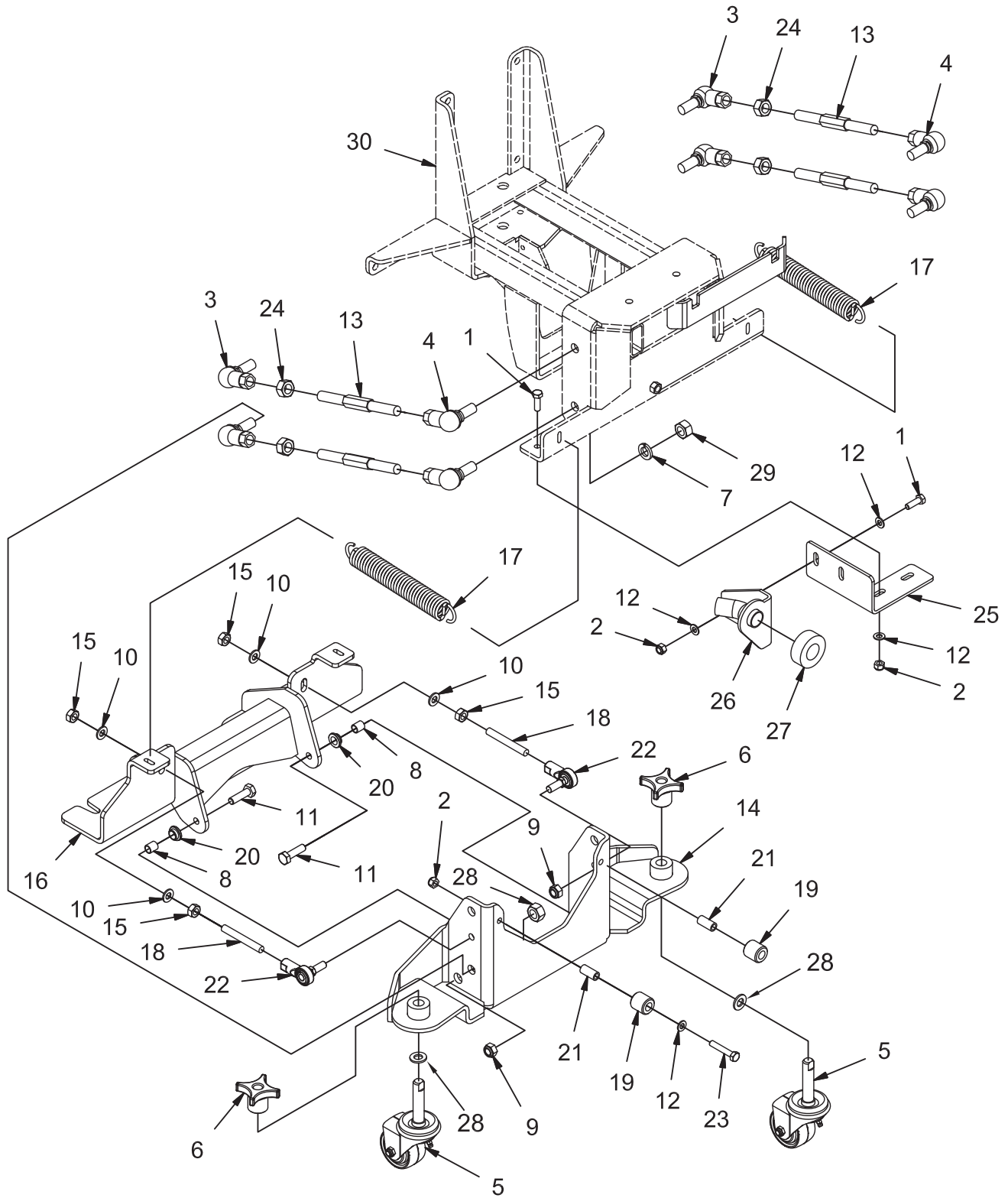

REV D

SQUEEGEE LINKAGE GROUP (730158)

Parts List 730158			
ITEM	PART NUMBER	QTY	DESCRIPTION
1	11039567	4	BOLT, M8-1.25 X 25 HH SS
2	12040259	6	NUT, M8-1.25 ESN SS
3	16046054	4	ROD END, M14 RH THRDS
4	16046062	4	ROD END, M14 LH THRDS
5	3343816	2	CASTER
6	3343819	2	KNOB
7	3400414	8	LOCK WASHER, 9/16 HS MED
8	600525	2	SPACER, .406 B .50 OD .57 T
9	730339	4	NUT, M10-1.50 ESN SS
10	730344	4	WASHER, M10 SS
11	730345	2	BOLT, M10-1.50 X 35 HH SS
12	730609	8	WASHER, M8 SS
13	730662	4	ROD, SQUEEGEE
14	730674	1	WELDMENT, SQU BRACKET
15	730718	4	NUT, M10-1.50 HEX SS
16	730720	1	WELDMENT, SQU MNT
17	730742	2	SPRING, EXT, .160 W 1.25 OD 10.25 L SS
18	730743	2	ROD, TREADED, M10-1.50
19	730744	2	ROLLER, SQU
20	730750	2	BUSHING, BRONZE, FLANGED. .50 B .62 OD .31 T
21	730751	2	SPACER, .344 B .500 OD 1.06 T
22	730753	2	ROD END, M10-1.50
23	730754	2	BOLT, M8-1.25 X 45 HH SS
24	731176	4	NUT, M14-1.50 HEX SS
25	730839	1	BRACKET, ADJ
26	730847	1	WELDMENT, HOSE ADJ
27	730848	1	SEAL
28	3401543	2	WASHER-EXT 1/2 ZP RIP STYLE
29	PART OF ROD END	8	NUT, M14-1.50 HEX
30	REF	-	SQUEEGEE LIFT WELDMENT

SQUEEGEE GROUP (730118)

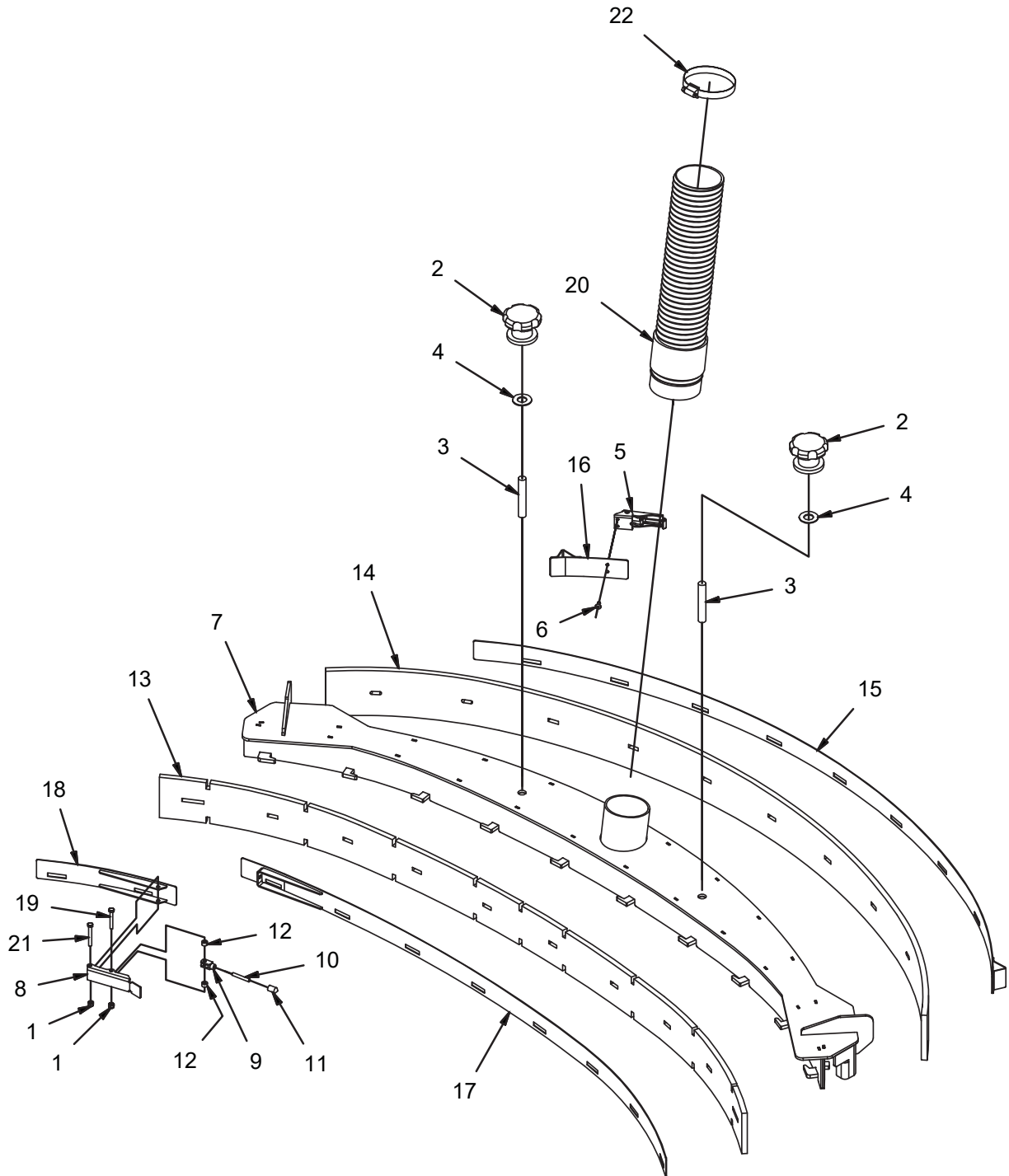

REV E

SQUEEGEE GROUP (730118)

Parts List 730118			
ITEM	PART NUMBER	QTY	DESCRIPTION
1	12040283	2	NUT, M5 - 0.8 ESN SS
2	3343814	2	KNOB
3	3343903	2	STUD, 1/2-13 X 3.00 SS
4	3401543	2	WASHER, TOOTHED PERIPHERY
5	730652	1	LATCH, UNDER CENTER
6	730654	2	RIVET, BLIND, .156 D X .062 - .125 GRIP SS
7	730764	1	WELDMENT, SQUEEGEE
8	730780	1	LATCH, BODY
9	730781	1	CLEVIS, M5-0.8
10	730782	1	ROD, M5-0.8
11	730783	1	ROD, NOSE
12	730784	2	SPACER, .203 B .375 OD .210 T
13	730787	1	SQUEEGEE BLADE, FRONT
14	730788	1	SQUEEGEE BLADE, REAR
15	730791	1	WELDMENT, REAR RETAINER
16	730796	1	WELDMENT, REAR RETAINER, SHORT
17	730798	1	WELDMENT, FRONT RETAINER
18	730800	1	WELDMENT, FRONT RETAINER, SHORT
19	730802	1	BOLT, M5-0.8 X 35 HH SS
20	730985	1	ASSEMBLY, LOWER SQU HOSE
21	731130	1	BOLT, M5-0.8 X 40 HH SS
22	731144	1	CLAMP, HOSE, 2.25 - 3.25

SIDE SQUEEGEE GROUP - RH (730120)

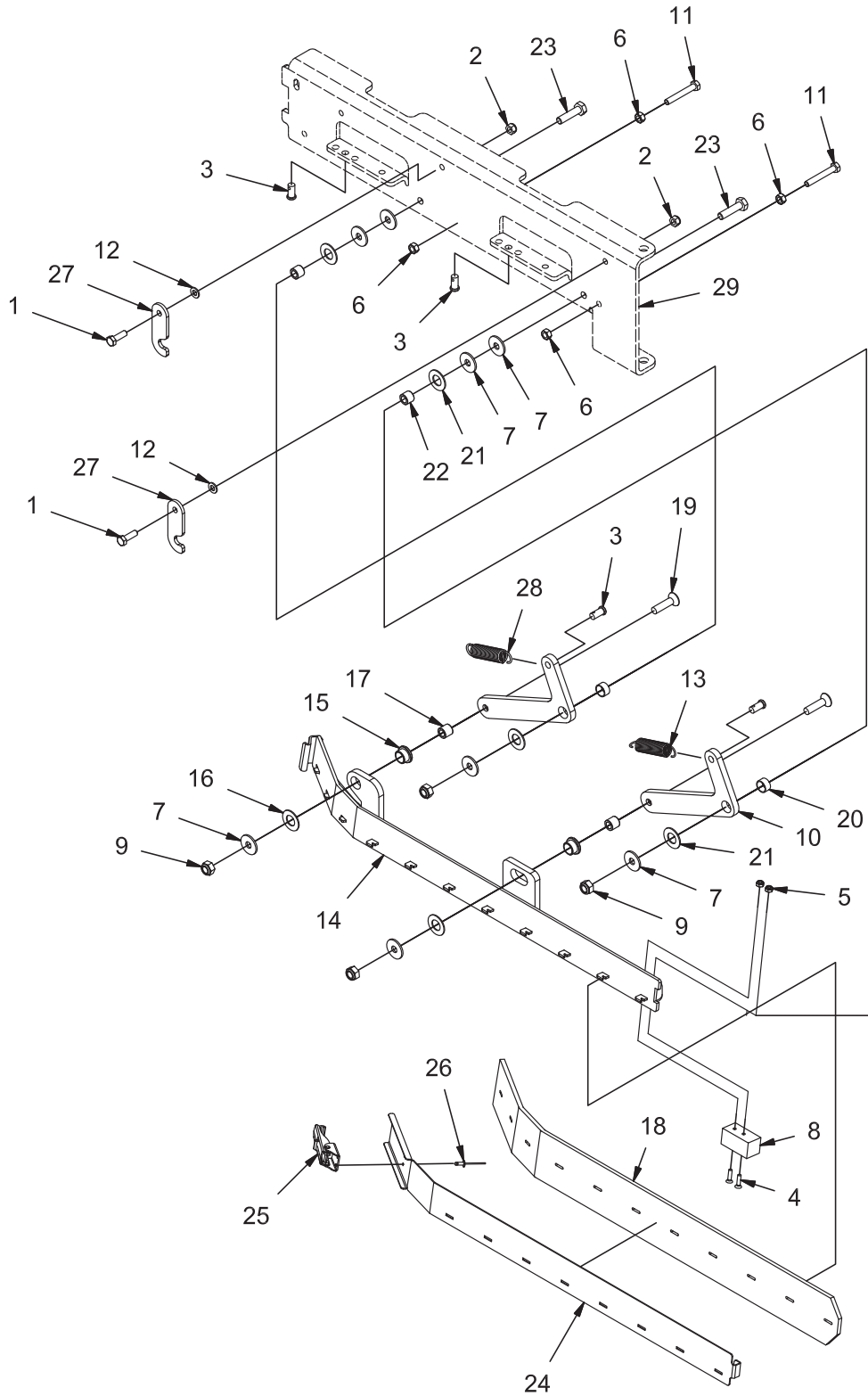

REV C

SIDE SQUEEGEE GROUP - RH (730120)

Parts List 730120			
ITEM	PART NUMBER	QTY	DESCRIPTION
1	11039567	2	BOLT, M8-125 X 25 HH SS
2	12040259	2	NUT, M8-1.25 ESN SS
3	711679	4	PIN, CLEVIS, .375 X .75
4	712544	2	SCR-FHMS 10-24 X 3/4 SS
5	712638	2	NUT, 10-32 ESN SS
6	717029	4	NUT, M8-1.25 SS
7	717040	8	WASHER, FENDER, .413 B 1.18 OD .098 T SS
8	730063	1	BLOCK, SIDE SQUEEGEE SLIDER
9	730339	4	NUT, M10-1.50 ESN SS
10	730346	2	ARM, SIDE SQU, RH
11	730507	2	BOLT, M8-1.25 X 55 HH SS
12	730609	2	WASHER, M8 SS
13	730619	1	SPRING, EXT, .07 W .75 OD 3.50 L SS
14	730630	1	WELDMENT, SQU MNT, RH
15	730640	2	BUSHING, BRONZE FLANGED, .62 B .75 OD .50T
16	730641	2	WASHER, BACKED THRUST .66 B 1.25 OD .06 T
17	730643	2	SPACER, .406 X .623 OD .575 T SS
18	730644	1	SQUEEGEE, SIDE
19	730645	2	SCREW, M10-1.50 X 40 FLAT HD SOC HD SS
20	730646	2	BEARING, DU, .63 B .72 OD .38 T
21	730647	4	WASHER, THRUST, .66 B 1.25 OD .06 T
22	730648	2	SPACER, .406 X .624 OD .515 T SS
23	730649	2	BOLT, M10-1.50 X 40 HH SS
24	730650	1	STRAP, RH SQU
25	730652	1	LATCH, UNDER CENTER
26	730654	2	RIVET,BLIND, .156 D X .062 - .125 GRIP SS
27	730990	2	LATCH, DOUBLE SCRUB
28	731183	1	SPRING, EXT, .09 W .75 OD 3.50 L SS
29	REF	-	SQU MNT CHANNEL, RH

SIDE SQUEEGEE GROUP - LH (730157)

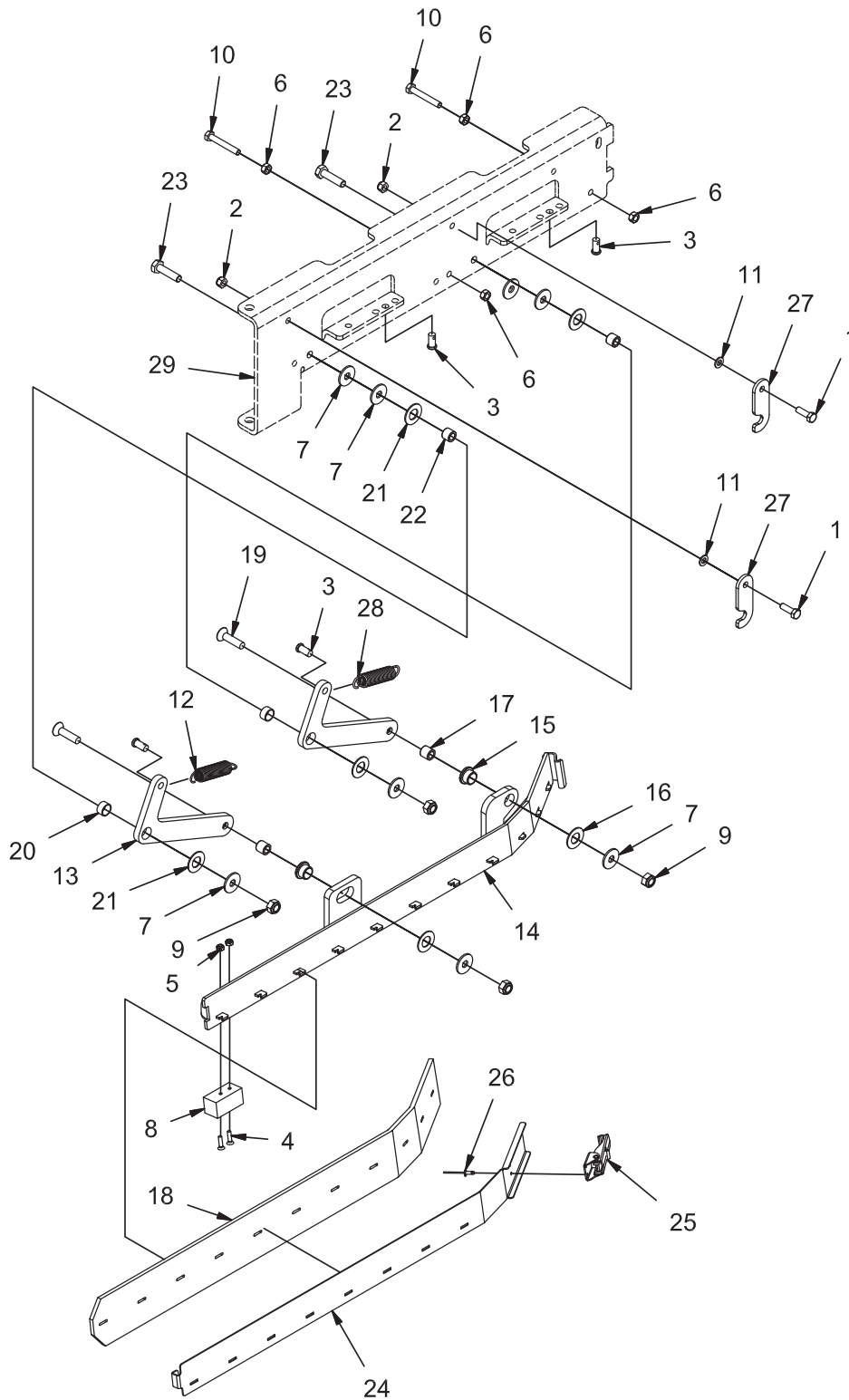

REV C

SIDE SQUEEGEE GROUP - LH (730157)

Parts List 730157			
ITEM	PART NUMBER	QTY	DESCRIPTION
1	11039567	2	BOLT, M8-125 X 25 HH SS
2	12040259	2	NUT, M8-1.25 ESN SS
3	711679	4	PIN, CLEVIS, .375 X .75
4	712544	2	SCR-FHMS 10-24 X 3/4 SS
5	712638	2	NUT, 10-32 ESN SS
6	717029	4	NUT, M8-1.25 SS
7	717040	8	WASHER, FENDER, .413 B 1.18 OD .098 T SS
8	730063	1	BLOCK, SIDE SQUEEGEE SLIDER
9	730339	4	NUT, M10-1.50 ESN SS
10	730507	2	BOLT, M8-1.25 X 55 HH SS
11	730609	2	WASHER, M8 SS
12	730619	1	SPRING, EXT, .07 W .75 OD 3.50 L SS
13	730620	2	ARM, SIDE SQU, LH
14	730637	1	WELDMENT, SQU MNT, LH
15	730640	2	BUSHING, BRONZE FLANGED, .62 B .75 OD .50T
16	730641	2	WASHER, BACKED THRUST .66 B 1.25 OD .06 T
17	730643	2	SPACER, .406 X .623 OD .575 T SS
18	730644	1	SQUEEGEE, SIDE
19	730645	2	SCREW, M10-1.50 X 40 FLAT HD SOC HD SS
20	730646	2	BEARING, DU, .63 B .72 OD .38 T
21	730647	4	WASHER, THRUST, .66 B 1.25 OD .06 T
22	730648	2	SPACER, .406 X .624 OD .515 T SS
23	730649	2	BOLT, M10-1.50 X 40 HH SS
24	730651	1	STRAP, LH SQU
25	730652	1	LATCH, UNDER CENTER
26	730654	2	RIVET,BLIND, .156 D X .062 - .125 GRIP SS
27	730990	2	LATCH, DOUBLE SCRUB
28	731183	1	SPRING, EXT, .09 W .75 OD 3.50 L SS
29	REF	-	SQU MNT CHANNEL, LH

SOLUTION TANK GROUP (730121)

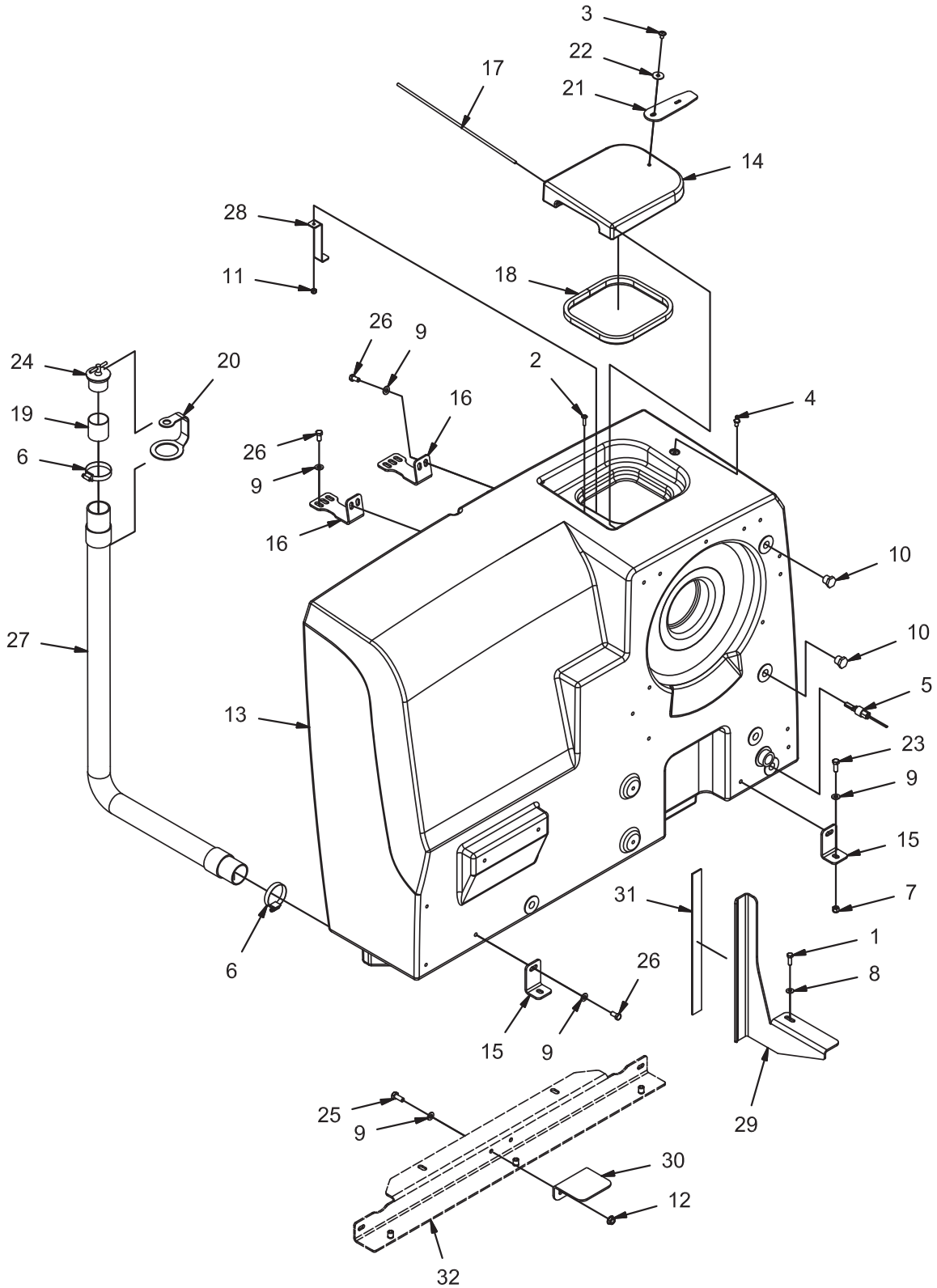

REV G

SOLUTION TANK GROUP (730121)

Parts List 730121			
ITEM	PART NUMBER	QTY	DESCRIPTION
1	11038247	1	BLT-HH M8-1.25 X 25 STL ZINC
2	11177161	1	SCREW, M6-1.00 X 25 BUTTON HD CAP W/FLANGE SS
3	11177253	1	SC BHCS W/ FLANGE M8-1.25 X 12 SS
4	3300376	1	STUD, 10MM BALL
5	3302737-1	1	WIRE ASSY, SWITCH - LEVEL LS7
6	3312189	2	CLAMP, HOSE, 2.00
7	3400340	2	NUT, 3/8-16 ESN SS
8	3400384	1	WASHER, 5/16 BELLEVILLE
9	3400385	10	WASHER, 3/8, BELLEVILLE
10	500122	2	1/2 NPT PLASTIC PLUG
11	600933	1	NUT, M6-1.00 ESN SS
12	600936	2	NUT, M10-1.50 FLNG
13	730458	1	TANK, SOLUTION
14	730480	1	COVER, ACCESS, SOL TANK
15	730491	2	BRACKET, TANK MNT
16	730492	2	BRACKET, TANK MNT
17	730493	1	ROD, SOL COVER
18	730494	1	SEAL, SOL COVER
19	730518	1	TUBE, SS
20	730520	1	LANYARD, CAP
21	730525	1	RETAINER, COVER
22	730526	1	WASHER, M8 FENDER SS
23	730529	2	SCREW, 3/8-16 X 1.00 HH SS
24	730531	1	PLUG, EXPANSION, 1.88
25	730958	2	BOLT, M10-1.50 X 25 HH SS
26	730959	6	SCREW, 3/8-16 X .750 HHC SS
27	730987	1	ASSEMBLY, SOL DRAIN HOSE
28	731184	1	INDICATOR, FULL TANK
29	731273-1	1	BRACKET, SUPPORT
30	731506	1	SUPPORT, ANGLE
31	PART OF 731273-1	1	FRICITION STRIP 281470-1
32	REF.	-	SUPPORT BEAM

SOLUTION CONTROL GROUP (730123)

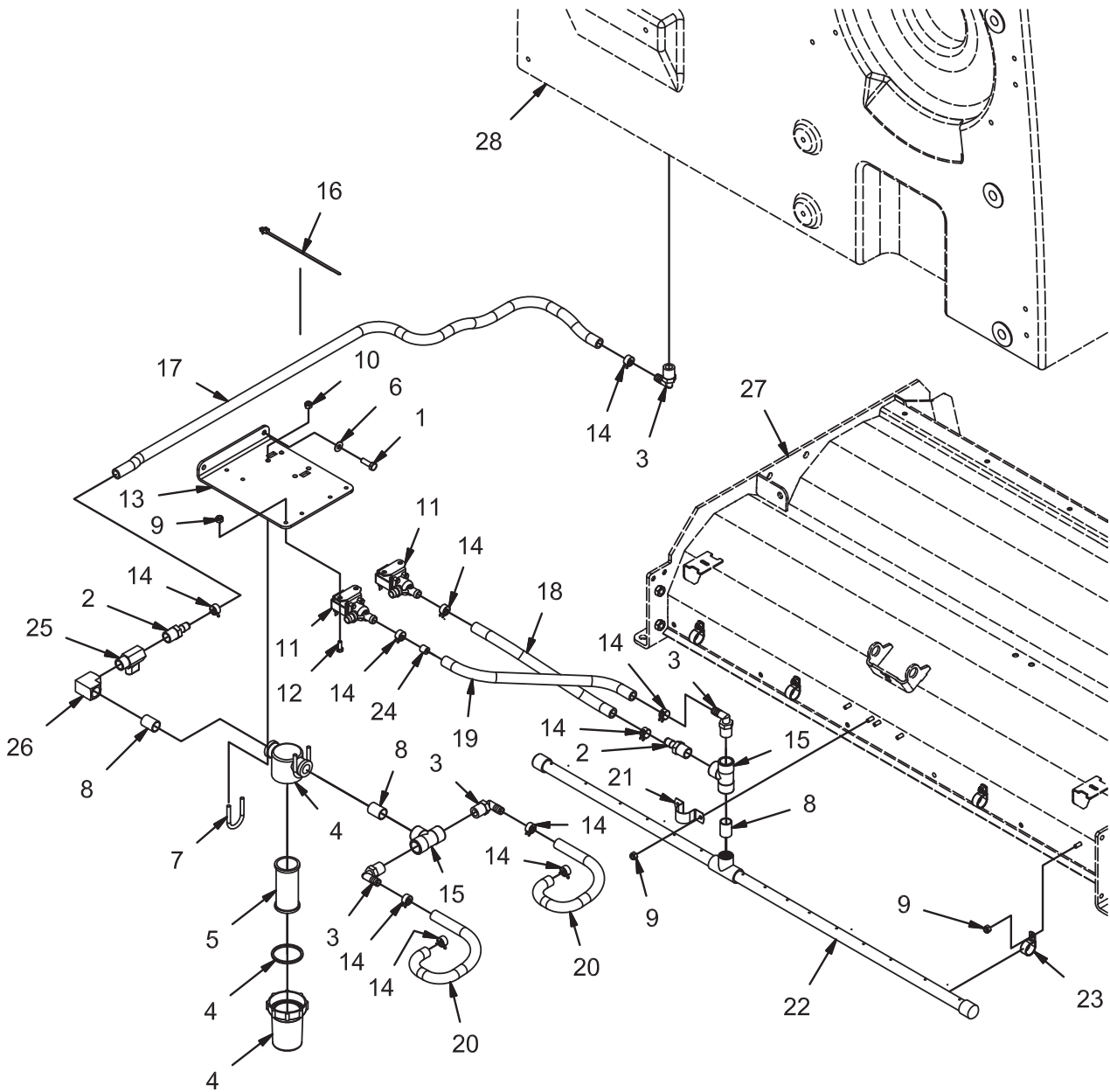

REV G

SOLUTION CONTROL GROUP (730123)

Parts List 730123			
ITEM	PART NUMBER	QTY	DESCRIPTION
1	11038247	2	BLT-HH M8-1.25 X 25 STL ZINC
2	3315534	2	FITTING, PLASTIC, STR, .50 NPT .50 BARB
3	3315535	4	FITTING, PLASTIC, 90, .50 NPT .50 BARB
4	3323501	1	FILTER ASSEMBLY
5	3332264	1	FILTER ELEMENT - SERVICE
6	3400384	2	WASHER, 5/16 BELLEVILLE
7	3401981	2	CLAMP
8	383465	3	1/2 NPT CLOSE PIPE NIPPLE, BRASS
9	600933	10	NUT, M6-1.00 ESN SS
10	712667	4	NUT, FIBER INSERT 1/4-20 SS
11	730899	2	VALVE, SOLENOID, 12-V W/.406 DIA. ORIFICE
12	730934	4	BOLT, M6-1.00 X 16 HH SS
13	730955	1	BRACKET, FILTER MNT
14	730962	10	CLAMP, WIRE HOSE
15	730966	2	FITTING, PVC TEE, FEMALE 1/2 NPT
16	730968	4	TIE, MOUNTED CABLE
17	730970	1	TUBING, .50 ID X 48.00 VINYL
18	730971	1	TUBING, .50 ID X 18.50 VINYL
19	730972	1	TUBING, .50 ID X 20.75 VINYL
20	730973	2	TUBING, .50 ID X 14.00 VINYL
21	730974	1	CLAMP, CONDUIT, 1"
22	731389	1	SOLUTION DELIVERY BAR
23	731218	4	CLAMP, .88 HOSE
24	731244	1	ORIFICE, SOLUTION
25	731378	1	BALL VALVE, 1/2" NPT, BRASS
26	731380	1	FITTING, ELBOW, 1/2" FNPT, BRASS
27	REF.	-	SCRUB HEAD
28	REF.	-	SOLUTION TANK

RECOVERY TANK GROUP (730122)

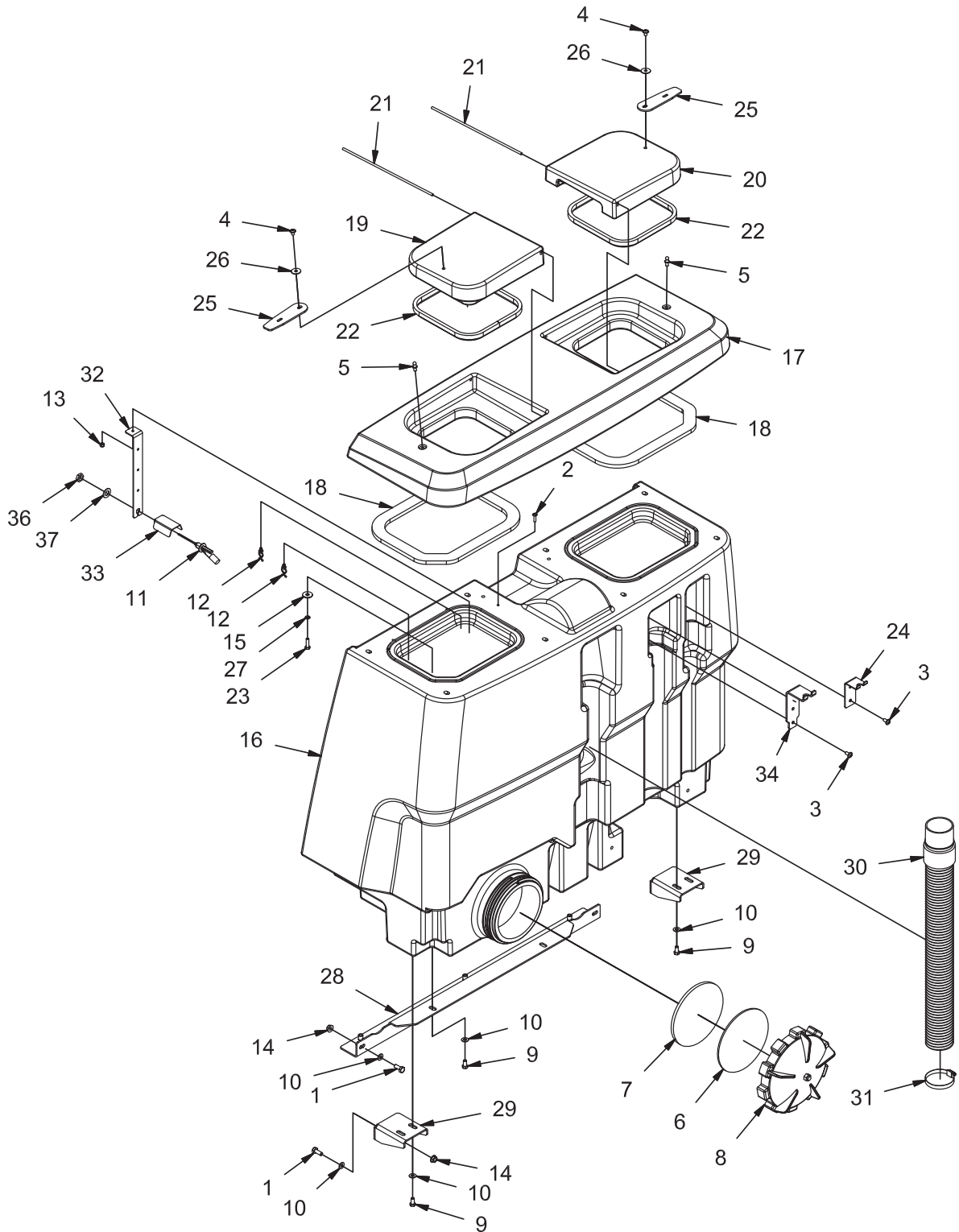

REV H

RECOVERY TANK GROUP (730122)

Parts List 730122			
ITEM	PART NUMBER	QTY	DESCRIPTION
1	11039328	6	BOLT, M10-1.50 X 25 HH SS
2	11177161	1	SCREW, M6-1.00 X 25 BUTTON HD CAP W/FLANGE SS
3	11177187	4	SC-BHCS W/ FLANGE M8 X 1.25 X 16 SS
4	11177253	2	SC BHCS W/ FLANGE M8-1.25 X 12 SS
5	3300376	2	STUD, 10MM BALL
6	3309098	1	PLATE, BACKING FOR 9" CAP GASKET
7	3315258	1	SEAL, CAP
8	3336811	1	ASSEMBLY, CLEAN OUT CAP
9	3400335	4	SCREW, 3/8-16 X .750 HH SS
10	3400385	10	WASHER, 3/8, BELLEVILLE
11	500133-1	1	WIRE ASSY, SWITCH - FLOAT
12	600581	2	CLAMP, WIRE CLIP
13	600933	1	NUT, M6-1.00 ESN SS
14	600936	6	NUT, M10-1.50 FLNG
15	717040	8	WASHER, FENDER, .413 B 1.18 OD .098 T SS
16	730490	1	TANK, RECOVERY
17	730495	1	DEMISTER
18	730496	2	SEAL, DEMISTER
19	730497	1	COVER, LH REC TANK
20	730503	1	COVER, RH REC TANK
21	730504	2	ROD, REC COVER
22	730505	2	SEAL, REC COVER
23	730506	8	BOLT, M8-125 X 30 HH SS
24	730519	1	RETAINER, SOL HOSE
25	730525	2	RETAINER, COVER
26	730526	2	WASHER, M8 FENDER SS
27	730527	8	LOCK WASHER, M8 SS
28	730803-1	1	ASSEMBLY, SUPPORT BEAM
29	730805	2	WELDMENT, TANK BRACKET
30	730984	1	ASSEMBLY, UPPER SQUEEGEE HOSE
31	731144	1	CLAMP, HOSE, 2.25 - 3.25
32	731185	1	REC TANK FLOAT SW MNT
33	731415	1	GUARD, FLOAT
34	731528	1	RETAINER, RECOVERY HOSE
35	748433	1	WIRE ASSY, SWITCH - FLOAT
36	PART OF 500133	1	NUT
37	PART OF 500133	1	GASKET

RECOVERY TANK DRAIN GROUP (730179)

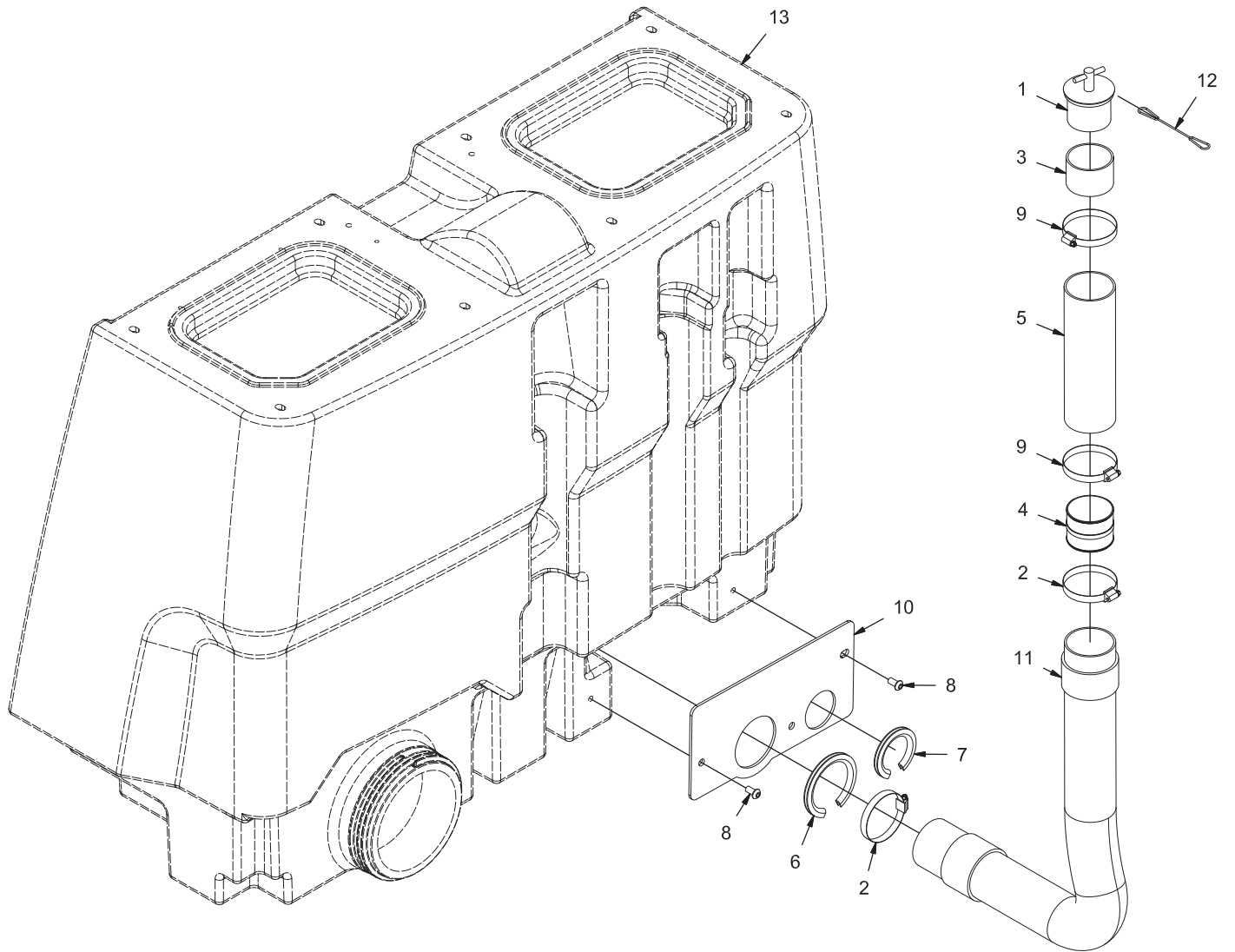

REV C

RECOVERY TANK DRAIN GROUP (730179)

Parts List			
ITEM	PART NUMBER	QTY	DESCRIPTION
1	3336089	1	PLUG, EXPANSION, 1.88
2	3343273	2	CLAMP, HOSE, 3.0 - 3.50
3	3345608	1	SUPPORT TUBE-SS, DRAIN HOSE
4	730511	1	W/D, VALVE BODY, TUBE
5	730517	1	TUBE, DRAIN VALVE
6	731140	1	EDGING, 3/16 X 12.0"
7	731141	1	EDGING, 3/16 X 8.38"
8	731143	2	BOLT, 3/8-16 X .75 BUTTON HD CAP SS
9	731144	2	CLAMP, HOSE, 2.25 - 3.25
10	731527	1	PLATE, HOSE SUPPORT
11	731533	1	ASSEMBLY, REC DRAIN HOSE
12	731539	1	LANYARD
13	REF.	1	TANK, RECOVERY

PLASTIC HOPPER GROUP (730173)

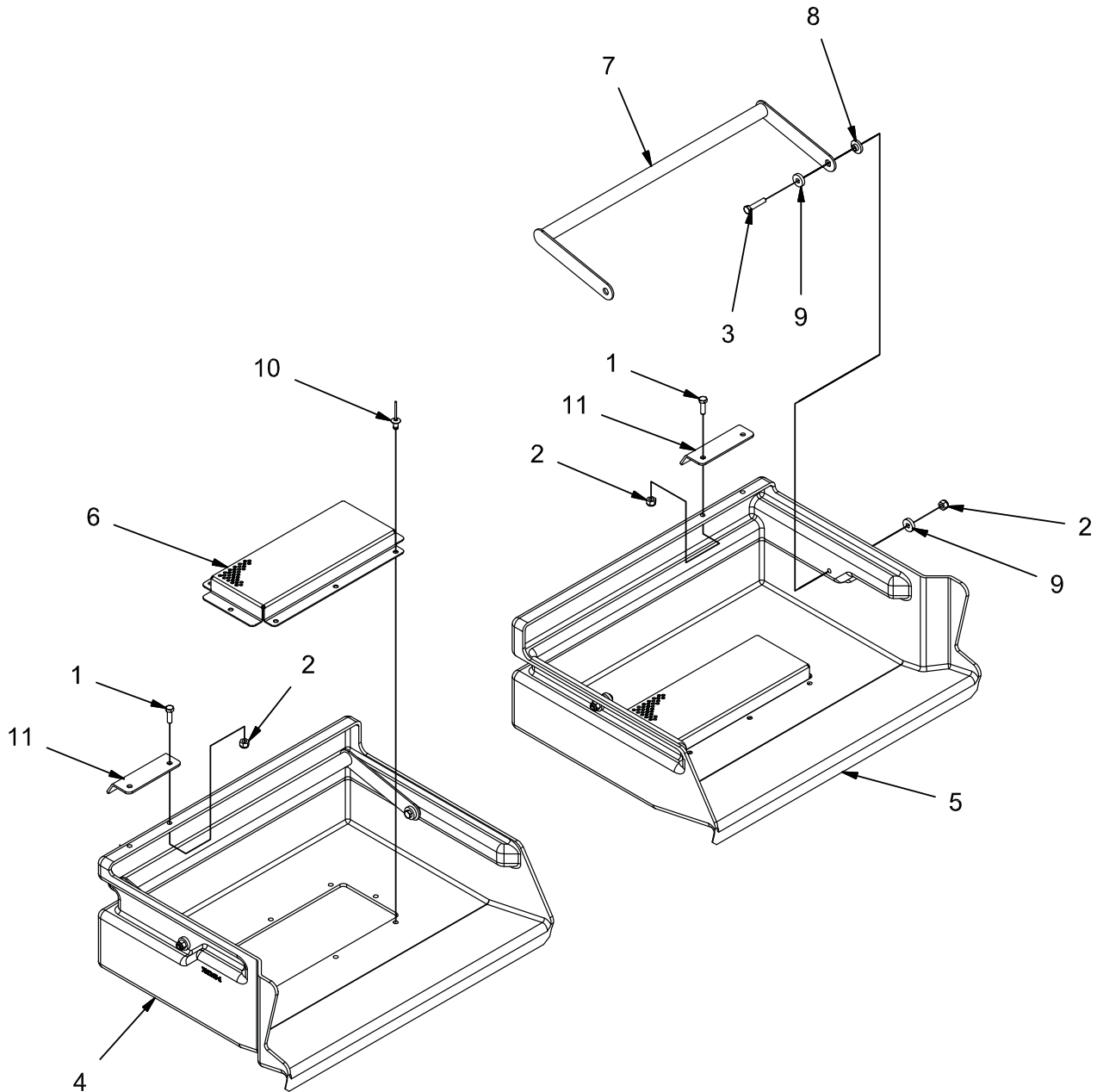

REV A

PLASTIC HOPPER GROUP (730173)

Parts List 730173			
ITEM	PART NUMBER	QTY	DESCRIPTION
1	600913	4	BOLT, M6-1.00 X 20 HH SS
2	600933	8	NUT, M6-1.00 ESN SS
3	731050	4	BOLT, M6-100 X 30 HH SS
4	731245-1	1	HOPPER, RIGHT
5	731246-1	1	HOPPER, LEFT
6	731247	2	SCREEN, HOPPER
7	731248	2	WELDMENT, HANDLE
8	731251	4	SPACER, PIVOT
9	731252	8	WASHER, THICK FENDER, M6, SS
10	731253	16	RIVET, BLIND, .25 D X .062 - .250 GRIP ALU
11	731368	2	RETAINER, HOPPER

HOPPER CRADLE GROUP (730174)

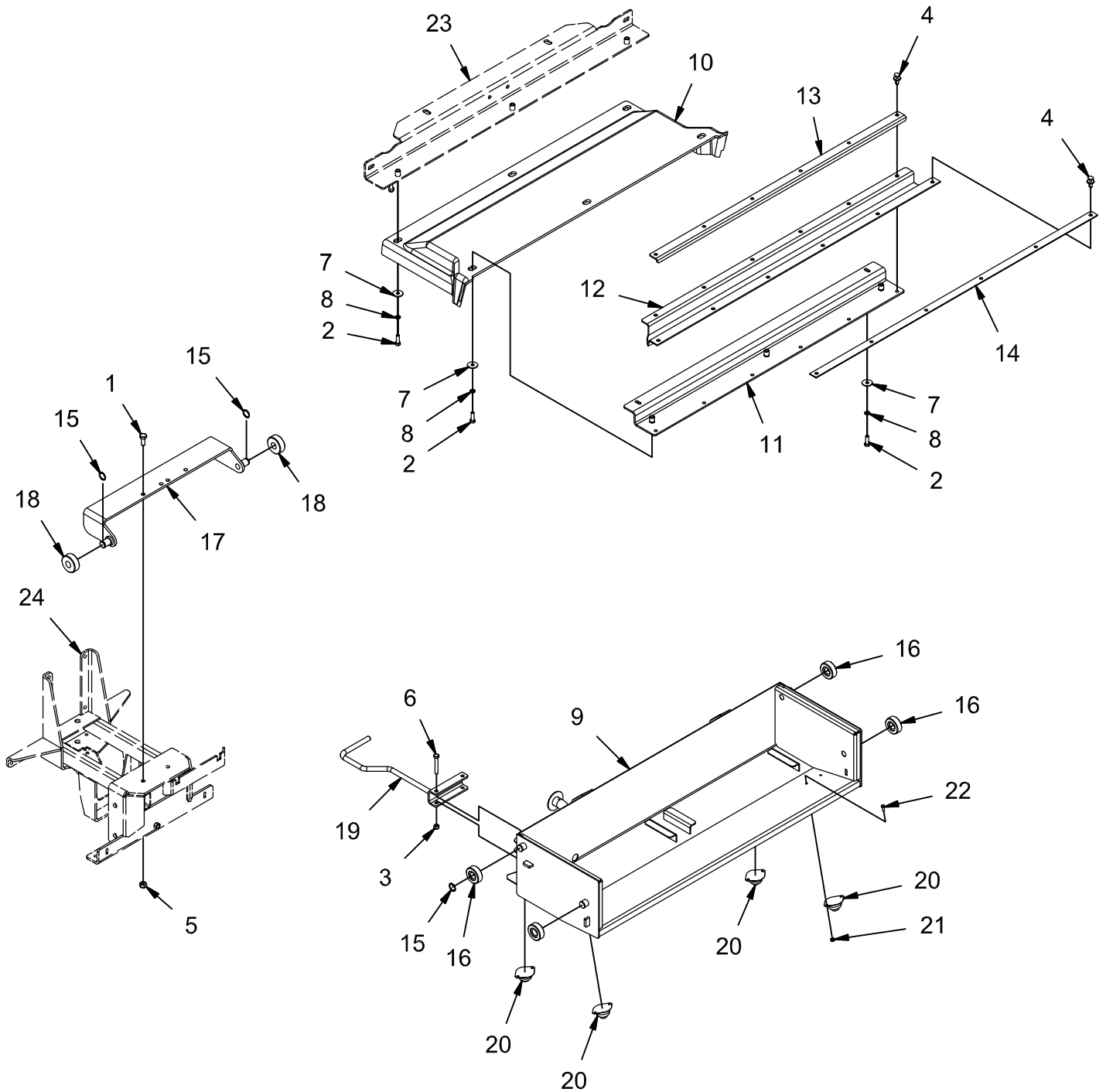

REV *

HOPPER CRADLE GROUP (730174)

Parts List 730124			
ITEM	PART NUMBER	QTY	DESCRIPTION
1	11038346	2	BOLT, M10-1.50 X 25 HH
2	11039567	8	BOLT, M8-1.25 X 25 HH SS
3	12040259	2	NUT, M8-1.25 ESN SS
4	600965	12	FASTENER, PRESS-IN
5	730339	2	NUT, M10-1.50 ESN SS
6	730507	2	BOLT, M8-1.25 X 55 HH SS
7	730526	8	WASHER, M8 FENDER SS
8	730527	8	LOCK WASHER, M8, SS
9	730807	1	WELDMENT, CRADLE
10	730825-1	1	COVER, HOPPER
11	730826-1	1	ASSEMBLY, COVER SUPPORT
12	730828	1	SEAL, HOPPER
13	730829	1	RETAINER, SEAL
14	730830	1	RETAINER, SEAL
15	730841	6	RETAINING RING, .75
16	730842	4	WHEEL
17	731133	1	WELDMENT, PUSH BRACKET
18	731136	2	ROLLER
19	731156-1	1	WELDMENT, CRADLE HANDLE
20	731239	4	BALL, ROLLER, 1" SS
21	731242	8	NUT, 10-32 ESN SS
22	731243	8	SCREW,#10-32 X .50 HH SS
23	REF	-	SUPPORT BEAM
24	REF.	-	SQUEEGEE LIFT

REAR BUMPER GROUP (730125)

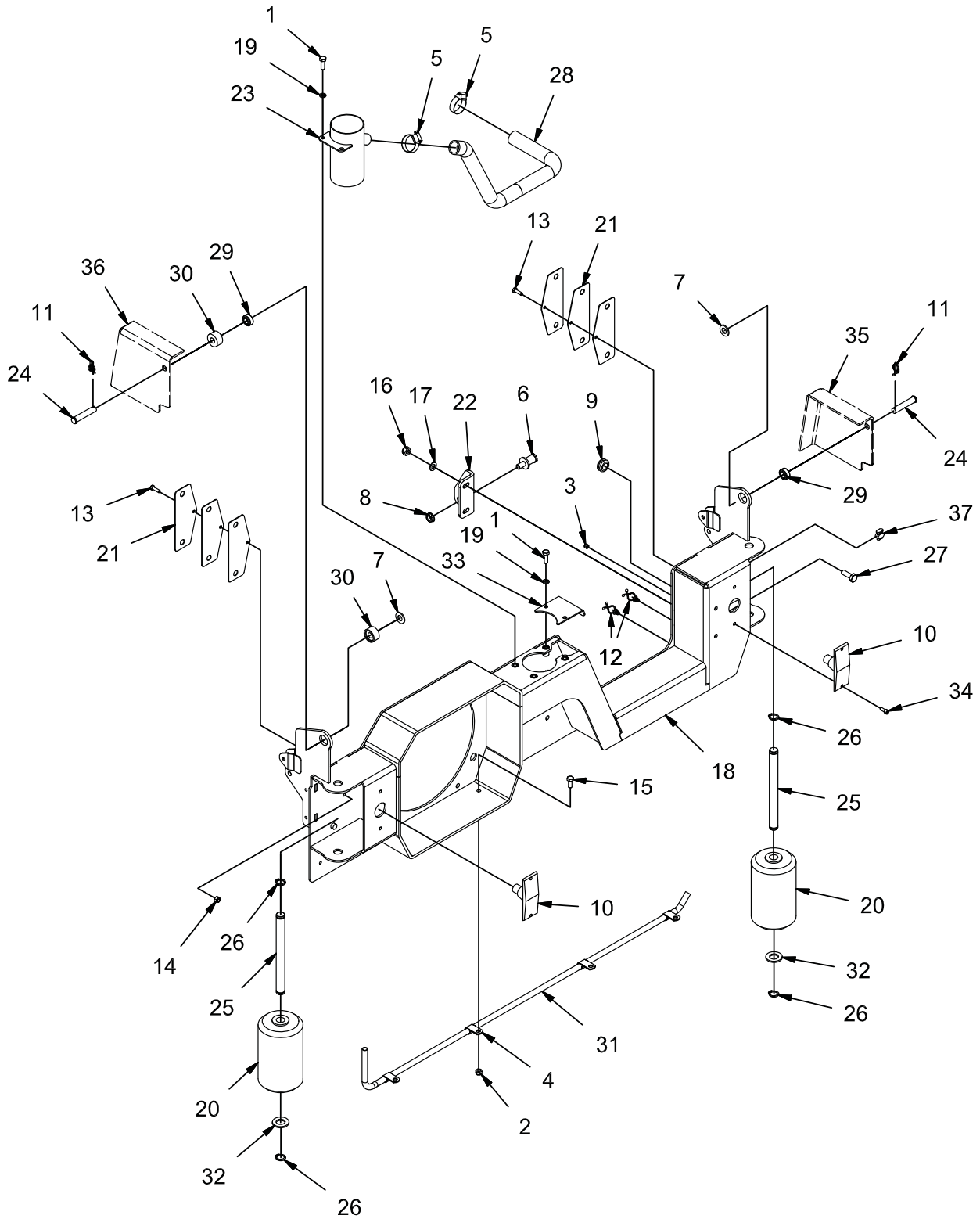

REV L

REAR BUMPER GROUP (730125)

Parts List 730125			
ITEM	PART NUMBER	QTY	DESCRIPTION
1	11039567	4	BOLT, M8-1.25 X 25 HH SS
2	12040259	4	NUT, M8-1.25 ESN SS
3	12040283	4	NUT, M5 - 0.8 ESN SS
4	3301158	4	CLAMP, .50 HOSE
5	3302193	2	CLAMP, HOSE, .75 - 1.25
6	3307248	1	STRIKER-LATCH
7	3400086	2	WASHER, 1/2, 1.063 X .531 X .094
8	3400394	1	NUT, 7/16-14 FLNG
9	600151	1	GROMMET, .63 ID .88 OD .25 T
10	600514-6	2	WIRE ASSY, TAIL LIGHT
11	600578	2	RUE-RING, .50
12	600581	2	CLAMP, WIRE CLIP
13	600913	2	BOLT, M6-1.00 X 20 HH SS
14	600933	2	NUT, M6-1.00 ESN SS
15	717030	4	BOLT, M8-1.25 X 20 HH SS
16	730339	2	NUT, M10-1.50 ESN SS
17	730344	2	WASHER, M10 SS
18	730360-1	1	ASSEMBLY, BUMPER
19	730527	4	LOCK WASHER, M8, SS
20	730719	2	ROLLER
21	730778	6	SHIM PLT
22	730789	1	STRIKER MNT LH
23	730868	1	WELDMENT, SQU TUBE
24	730875	2	PIN, CLEVIS 1/2 X 2.50 ZP
25	730876	2	PIN, ROLLER
26	730877	4	RETAINING RING, EXT, .750
27	730878	2	BOLT, M10-1.50 X 30 HH SS
28	730879	1	TUBING, HOPPER VAC
29	730882	2	BEARING, SPHERICAL
30	730883	2	SPACER, BUMPER
31	730885	1	TUBE, WIRE
32	730886	2	FLAT WASHER, .75 ZP
33	731189	1	COVER, HOSE PORT
34	831206	4	SCREW, M5-0.8 X 16 SHCS ZP
35	REF	-	FRAME
36	REF	-	FRAME
-	748982	1	HARNESS, LEFT TAIL LIGHT
-	748983	1	HARNESS, RIGHT TAIL LIGHT
37	742934	2	GROUND CONNECTOR, SEALED

REAR STEP GROUP (730055)

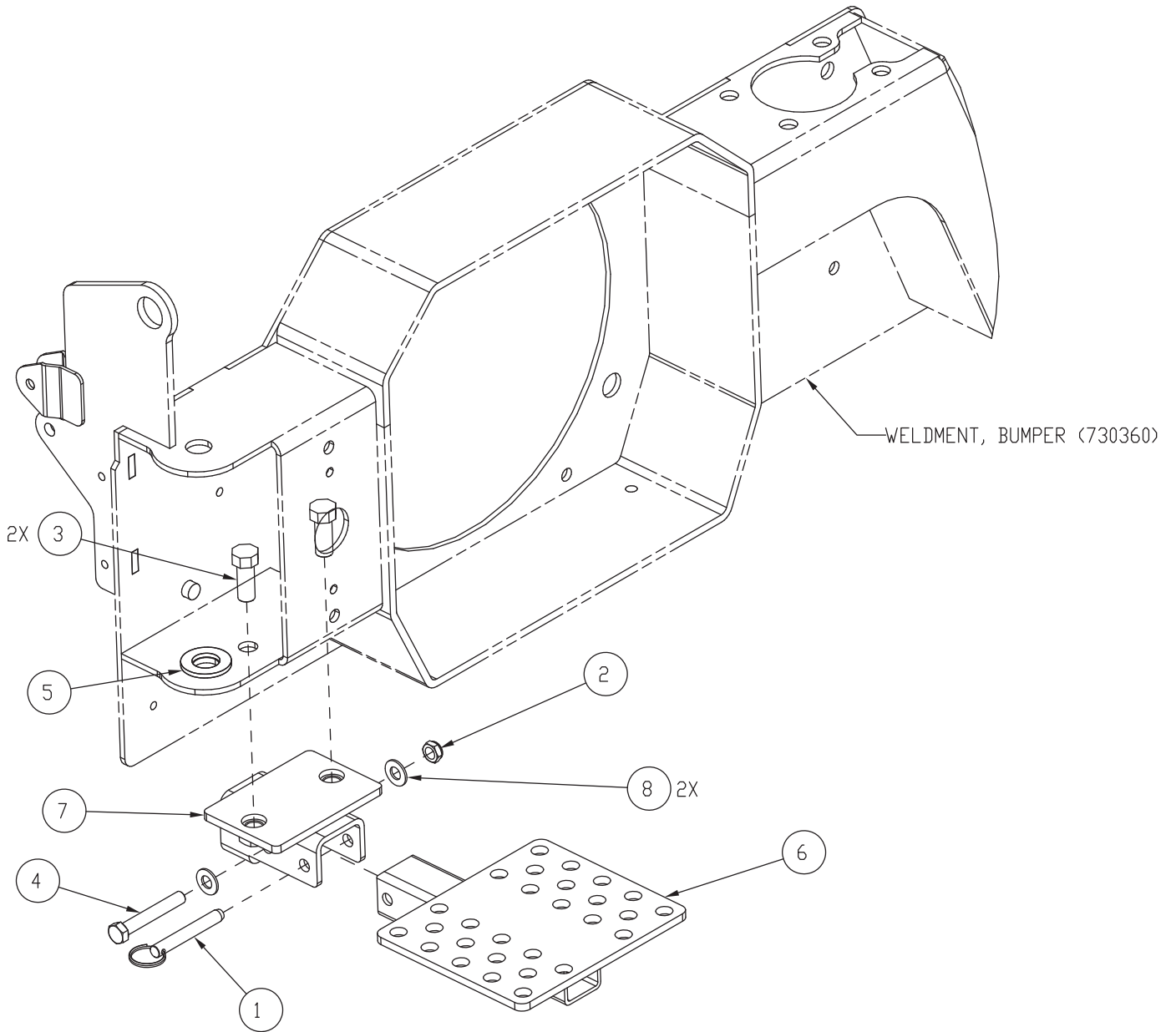

REV A

REAR STEP GROUP (730055)

Parts List 730055			
ITEM	PART NUMBER	QTY	DESCRIPTION
1	711028	1	PIN, QUICK RELEASE, 3/8" X 2" SS
2	711375	1	NUT-NYLOC 3/8-16 ZP
3	712010	2	SCR-HH 1/2-13 X 1.25 ZP GR 5
4	713048	1	SCR-HH 3/8-16 X 2.50 ZP GR 5
5	730886	1	WASHER-FLAT 3/4 ZP
6	731312	1	WELDMENT, REAR STEP, NAUTILUS
7	731315	1	WELDMENT, MOUNTING, REAR STEP
8	3400087	2	WASHER-FLAT 3/8 ZP

BUMPER LIFT GROUP (730159)

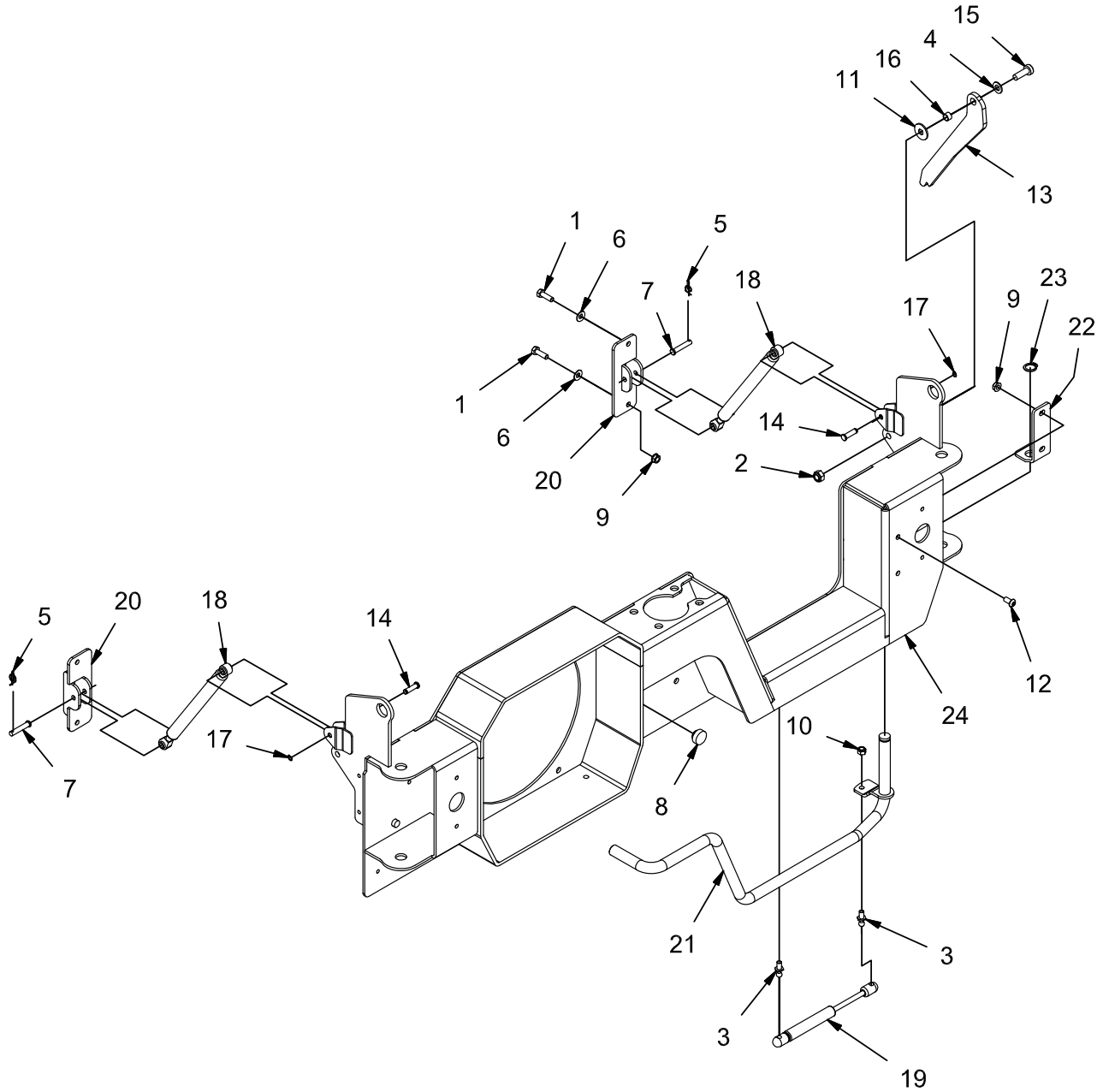

REV E

BUMPER LIFT GROUP (730159)

Parts List 730159			
ITEM	PART NUMBER	QTY	DESCRIPTION
1	11038247	4	BLT-HH M8-1.25 X 25 STL ZINC
2	12040069	1	NUT, M10-1.50 ESN
3	3300376	2	STUD, 10MM BALL
4	3400087	1	WASHER, 3/8
5	3400125	2	RUE-RING, .375
6	3400384	4	WASHER, 5/16 BELLEVILLE
7	3401982	2	PIN, CLEVIS, .313 X 1.625
8	600117	1	BUMPER, 1.00 X .339 T
9	600934	4	NUT, M8-1.25 FLNG
10	711374	2	NUT, FIBER INSERT 5/16-18
11	717040	1	WASHER, FENDER, .413 B 1.18 OD .098 T SS
12	730399	2	SCREW, M8-1.25 X 16 BUTTON HD CAP CZP
13	730758	1	SAFETY ARM
14	730779	2	PIN, BUMPER
15	730872	1	SCREW, M10-1.50 X 30 LOW PROFILE CAP SS
16	730873	1	SPACER, .406 B .498 OD .325 T
17	730874	2	RETAINING RING, EXT, .313
18	730887	2	GAS STRUT, 17.01 EXT 6.89 STK
19	730902	1	GAS STRUT, 8.8 EXT, 3.0 STK, 200N
20	730935	2	WELDMENT, STRUT MOUNT
21	731205	1	WELDMENT, BUMPER LEVER
22	731209	1	W/D, BUMPER, LEVER PIVOT
23	731212	1	RETAINING RING, EXT, HD .750
24	REF	-	REAR BUMPER

IMPELLER GROUP (730126)

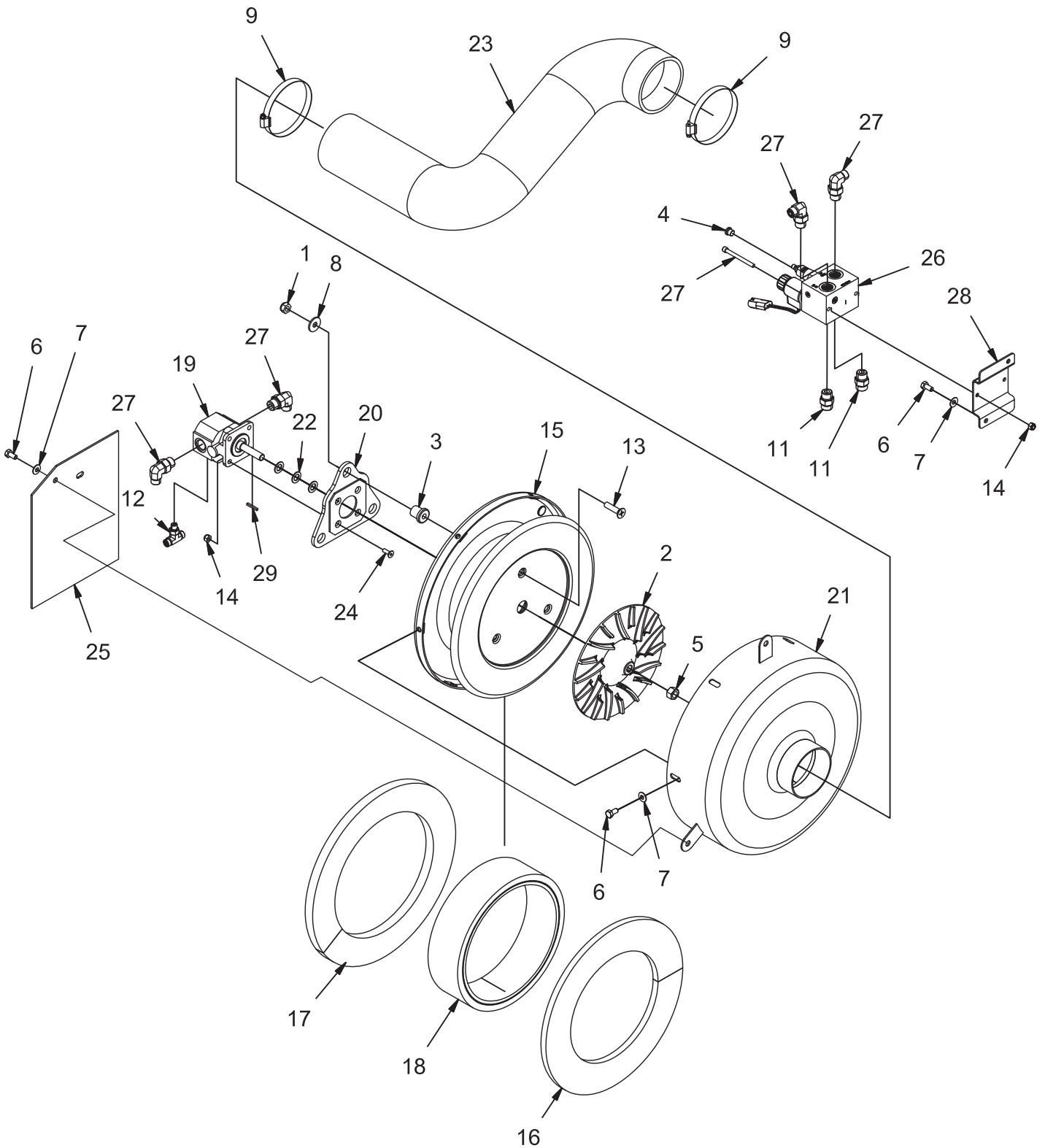

REV J

IMPELLER GROUP (730126)

Parts List 730126			
ITEM	PART NUMBER	QTY	DESCRIPTION
1	12040069	3	NUT, M10-1.50 ESN
2	3300133	1	IMPELLER
3	3300465	3	ISOLATOR, VIB
4	3331436	1	FITTING, PLUG, 4 O-RING
5	3400064	1	NUT, 1/2-20 UNF ZP
6	3400291	11	BOLT, M8-1.25 X 16 HH
7	3400384	11	WASHER, 5/16 BELLEVILLE
8	600363	3	WASHER, ISOLATOR
9	620176	2	CLAMP, HOSE, 4"
10	675520	4	FITTING, 90, 6 ORFS - 6 O-RING
11	675524	2	FITTING, STR, -8 ORFS - 8 SAE
12	675556	1	FITTING, TEE, 4 ORFS - 4 SAE
13	710028	3	SCREW, M10-1.50 X 40 FHMS
14	711373	6	NUT, FIBER INSERT 1/4-20
15	730463-1	1	IMPELLER HOUSING, MACHINED
16	730466	1	INSULATION, SOUND
17	730467	1	INSULATION, SOUND
18	730468	1	INSULATION, SOUND
19	730470	1	MOTOR, HYD, GEAR
20	730471	1	WELDMENT, MOTOR MNT
21	730474	1	WELDMENT, IMPELLER SHROUD
22	730479	3	PRECISION WASHER, .88 D .51 B .060 T
23	730501	1	HOSE, VACUUM FAN
24	730562	4	SCREW, 1/4-20 X .750 FHMS ZP
25	730639	1	FLAP, IMPELLER
26	730790-1	1	MANIFOLD, IMPELLER
27	730889	2	BOLT, 1/4-20 X 2.75 SOC HD ZP
28	730891	1	BRACKET, MANIFOLD
29	PART OF 730470	1	KEY, .125 SQ X 1.00

IMPELLER HYDRAULIC MANIFOLD ASSEMBLY (730790-1)

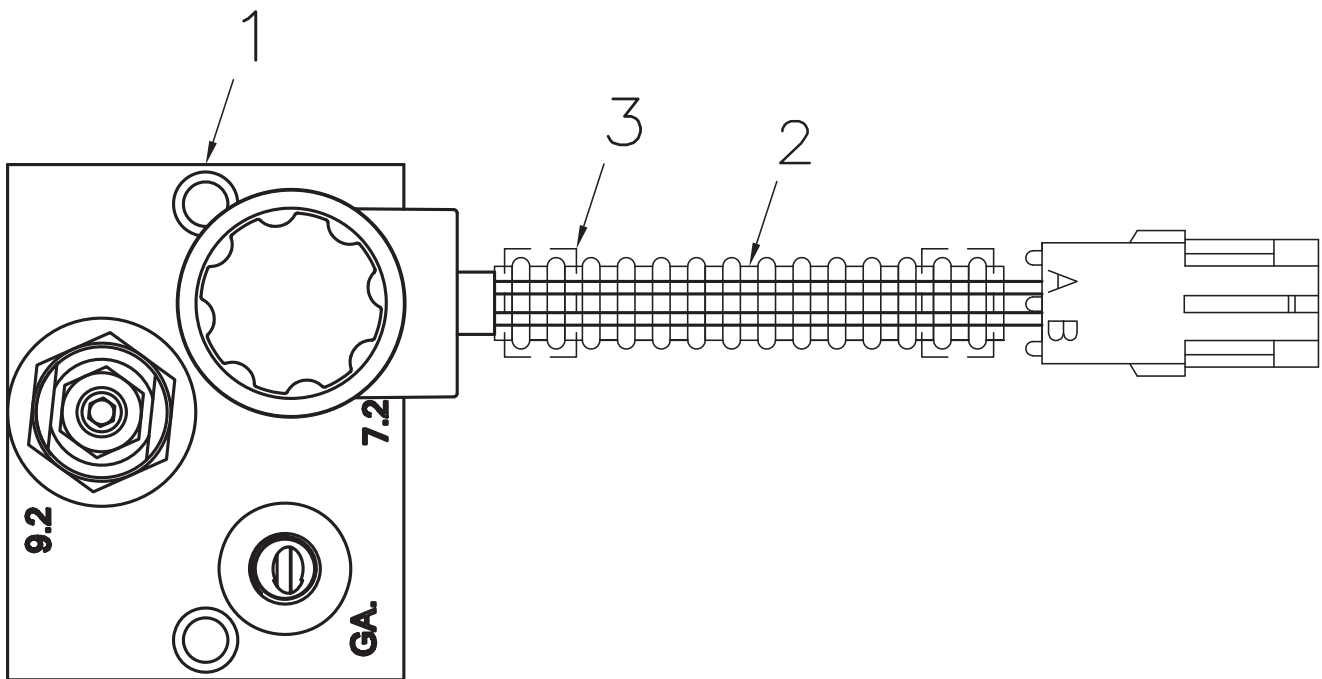

REV A

IMPELLER HYDRAULIC MANIFOLD ASSEMBLY (730790-1)

BILL OF MATERIAL			
ITEM	PART NO.	REQ'D	DESCRIPTION
1	730790	1	MANIFOLD, IMPELLER
2	741231	0.5 FT (6.0 IN)	CONDUIT – SPLIT 1/4” ID
3	000727	0.3 FT (4.0 IN)	TAPE, ELECTRICAL BLACK

HYDRAULIC RESERVOIR GROUP (730127)

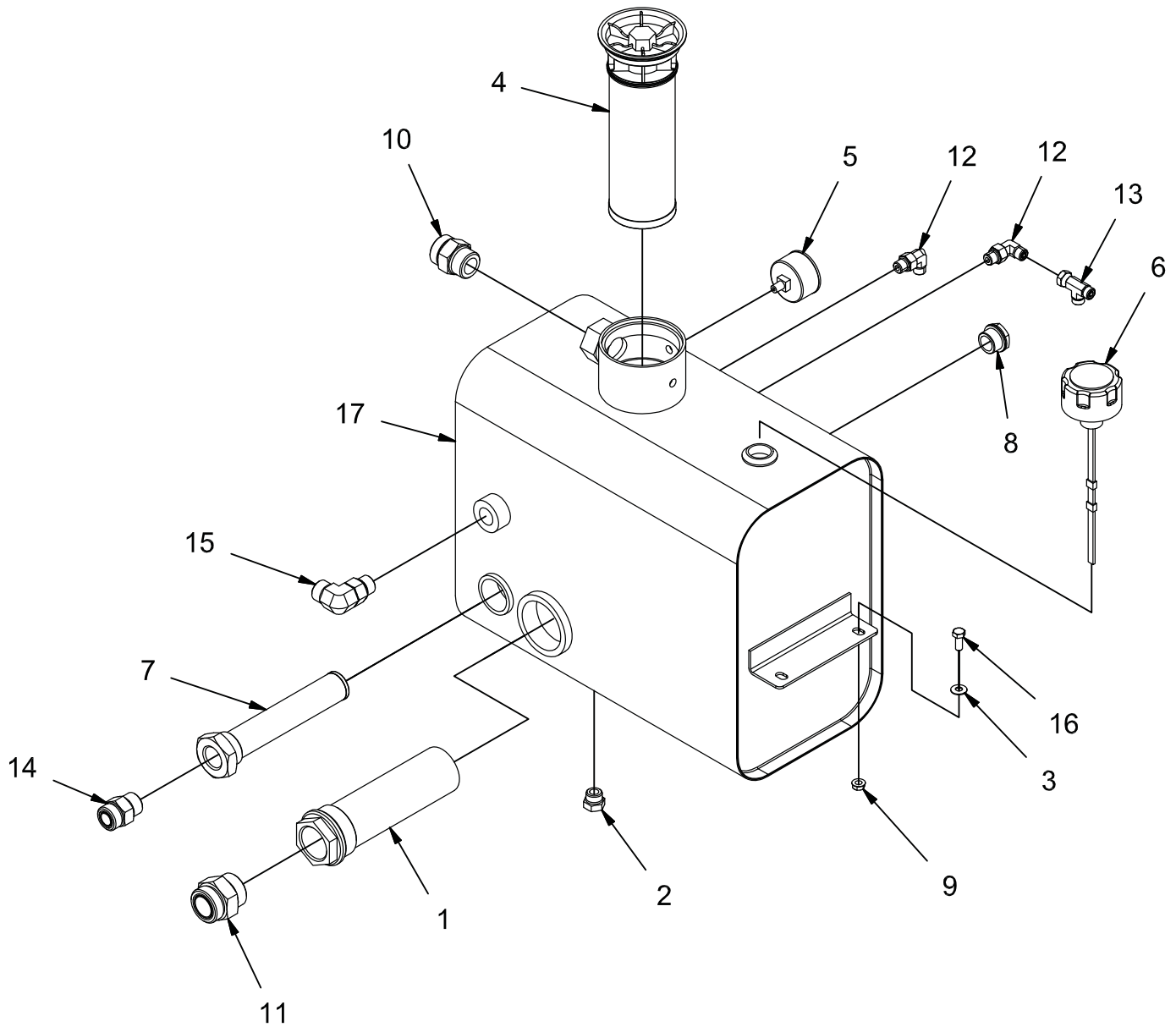

REV *

HYDRAULIC RESERVOIR GROUP (730127)

Parts List 730127			
ITEM	PART NUMBER	QTY	DESCRIPTION
1	3343836	1	STRAINER, HYDRAULIC, 20
2	3400164	1	FITTING, PLUG, 8 O-RING
3	3400384	4	WASHER, 5/16 BELLEVILLE
4	600182	1	FILTER ELEMENT, 10 MIC
5	600183	1	GAUGE, 0-60 PSI
6	600184	1	FILLER-BREATHER, 10 MIC
7	600185	1	STRAINER, 12
8	600531	1	SIGHT GAUGE
9	600934	4	NUT, M8-1.25 FLNG
10	675505	1	FITTING, STR, 16 ORFS - 16 SAE
11	675539	1	FITTING, STR, 20 ORFS - 20 SAE
12	675546	2	FITTING, 90, 4 ORFS - 6 SAE
13	675549	1	FITTING, RUN TEE, 4 ORFS - 4 SAE
14	675551	1	FITTING, STR, 12 ORFS - 12 SAE
15	675557	1	FITTING, 90, 10 ORFS - 10 SAE
16	717024	4	BOLT, M8-1.25 X 20 HH
17	730309	1	TANK, HYD RESERVOIR

HYDRAULIC PUMP GROUP (730136)

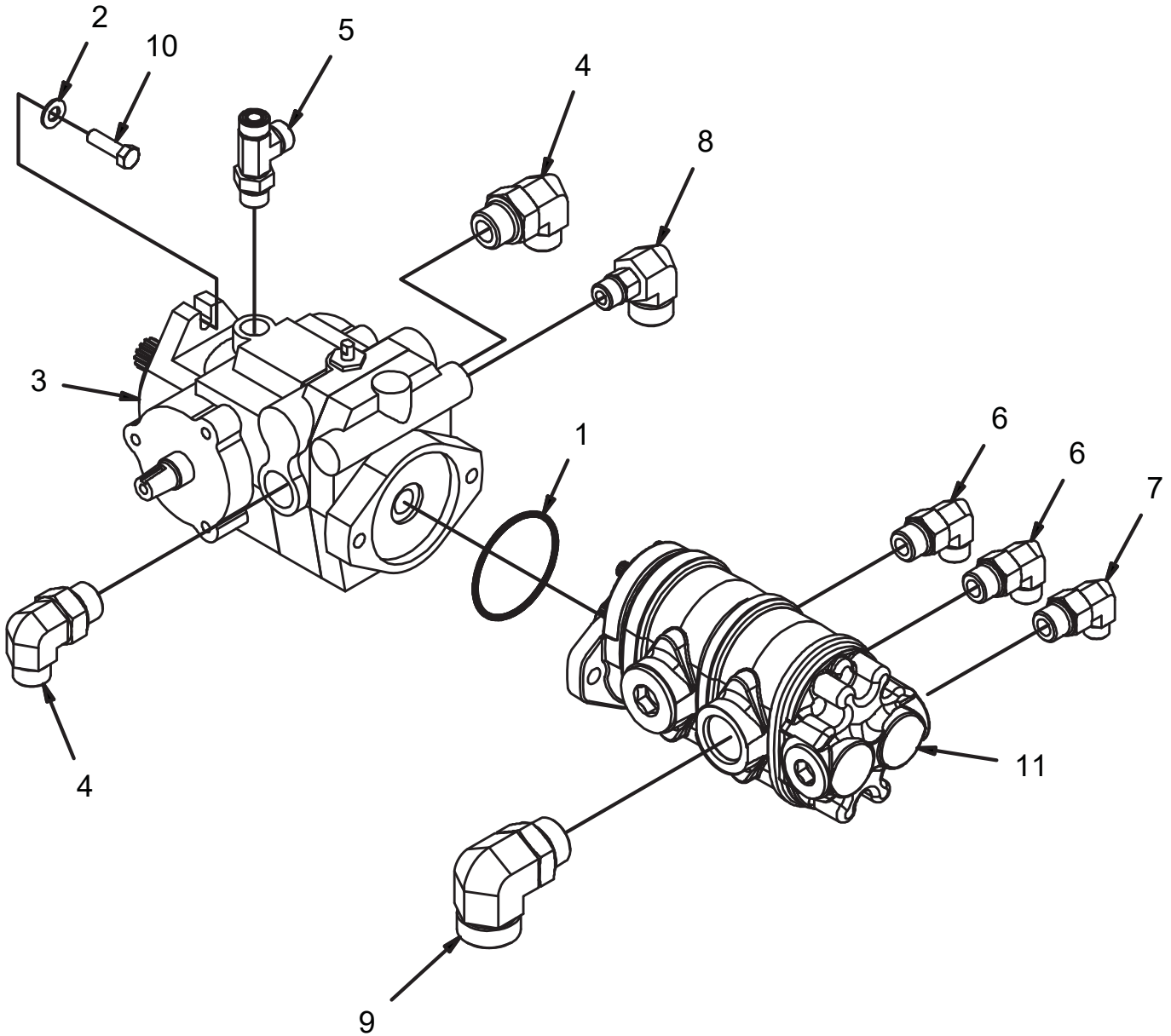

REV A

HYDRAULIC PUMP GROUP (730136)

Parts List - 730136			
ITEM	PART NUMBER	QTY	DESCRIPTION
1	3303711	1	O-RING
2	3400385	2	WASHER, 3/8, BELLEVILLE
3	600215	1	PUMP, PROPULSION
4	675500	2	FTG - ELBOW -10 ORFS TO -12 SAE
5	675525	1	FITTING, RUN TEE, 8 ORFS - 8 ORFS - 8 SAE
6	675528	2	FITTING, 90, -8 ORFS - 10 SAE
7	675532	1	FITTING, 90, 6 ORFS - 10 SAE
8	675543	1	FITTING, 90, 12 ORFS - 8 SAE
9	675553	1	FTG-STR THD 90 -20 ORFC TO -16 SAE
10	713043	2	SCREW, 3/8-16 X 1.25 HH
11	730310	1	PUMP, AUX

HYDRAULIC VALVE GROUP (730137)

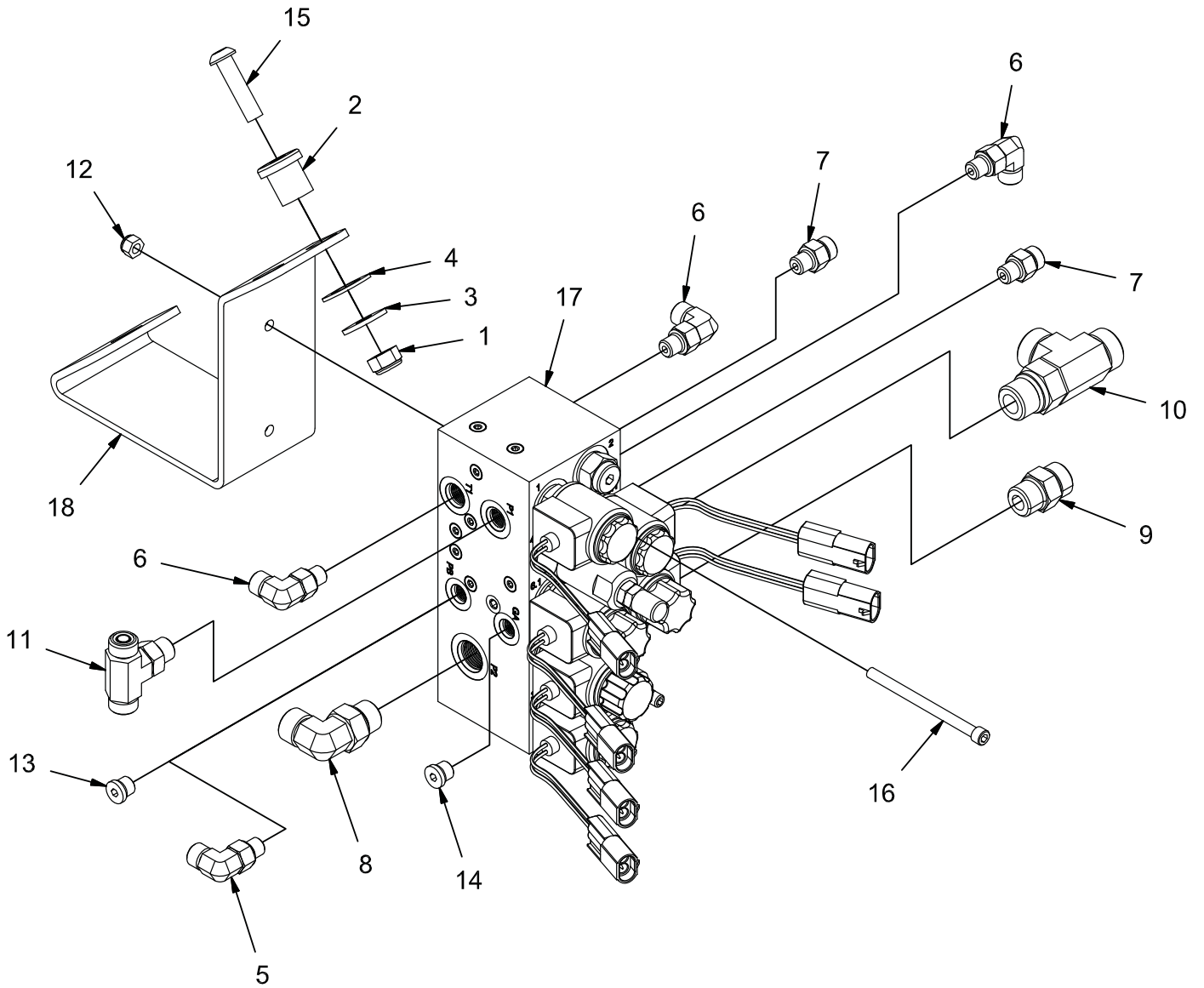

REV A

HYDRAULIC VALVE GROUP (730137)

Parts List 730137			
ITEM	PART NUMBER	QTY	DESCRIPTION
1	12040069	3	NUT, M10-1.50 ESN
2	3300465	3	ISOLATOR, VIB
3	600363	3	WASHER, ISOLATOR
4	66-431-A	3	WASHER, .77 B 1.25 OD .075 T
5	675507	1	FITTING, 90, 4 ORFS - 4 SAE (W/ OPT SIDE BRUSH)
6	675507	3	FITTING, 90, 4 ORFS - 4 SAE
7	675508	2	FITTING, STR, 4 ORFS - 4-SAE
8	675523	1	FITTING, 90, 8 ORFS - 8 SAE
9	675524	1	FITTING, STR, 8 ORFS - 8 SAE
10	675540	1	FITTING, RUN TEE, 10 ORFS - 10 SAE
11	675555	1	FITTING, TEE 6 ORFS - 6 SAE
12	711373	2	NUT, FIBER INSERT 1/4-20
13	3331436	1	FITTING, PLUG 4 O-RING (W/O OPT SIDE BRUSH)
14	3331436	1	FITTING, PLUG, 4 O-RING (GAUGE PORT)
15	730698	3	BOLT, M10-1.50 X 40 BUTTON HD CAP
16	730699	2	BOLT, 1/4-20 X 3.50 SOC HD CAP
17	730700	1	HYDRAULIC MANIFOLD ASSEMBLY
18	730711	1	MOUNT, MANIFOLD

HYDRAULIC MANIFOLD COMPONENTS GROUP (730170)

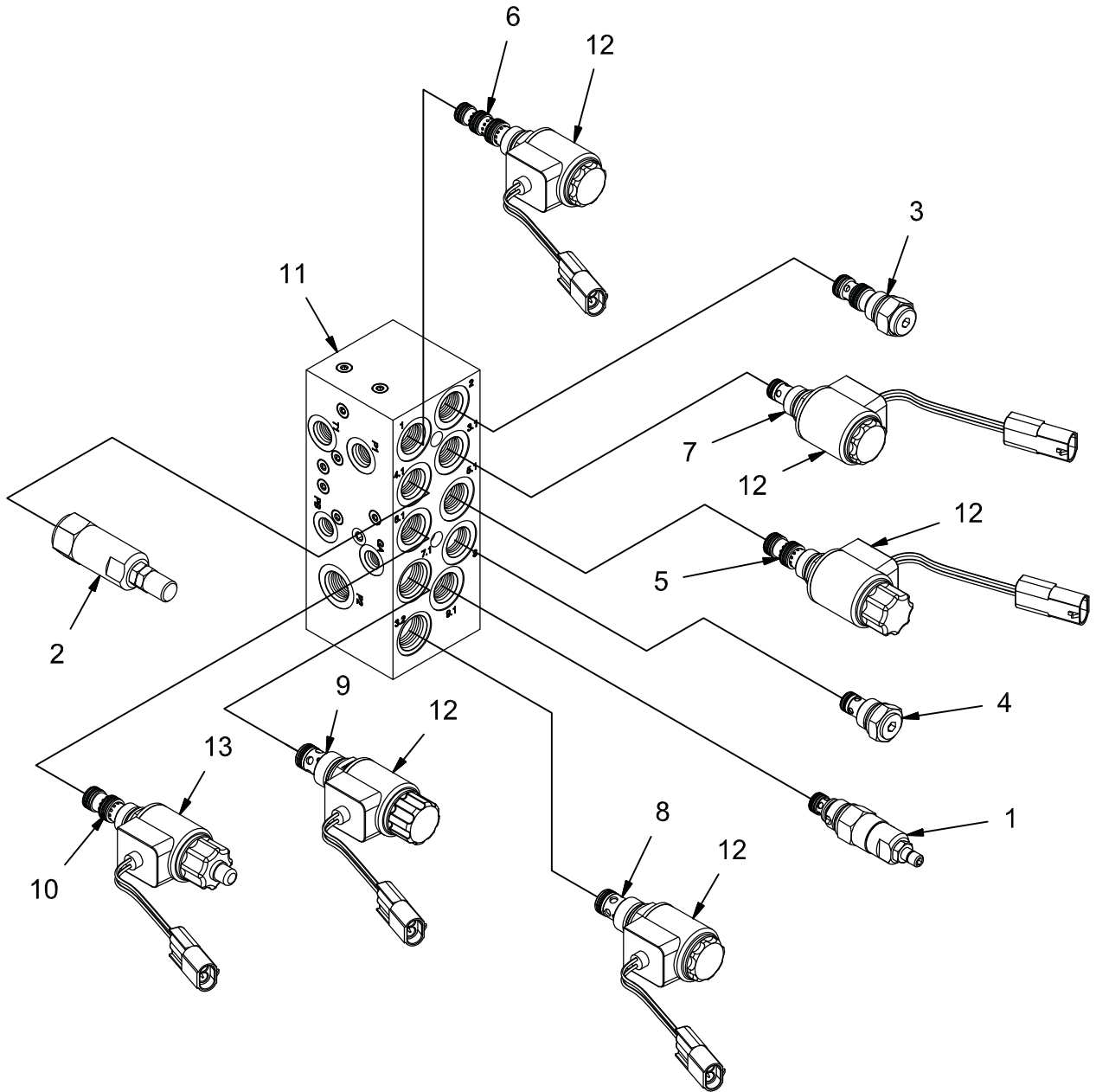

REV B

HYDRAULIC MANIFOLD COMPONENTS GROUP (730170)

Parts List 730170			
ITEM	PART NUMBER	QTY	DESCRIPTION
1	730701	1	PORT 9.1 - RV2 - RELIEF VALVE RELIEF VALVE, DB08P-01-C-N-330-V-250
2	730702	1	PORT 4.1 - RV3 - PRESSURE REDUCTION VALVE SOL. RED. VALVE, DR08-01-C-N-050-V-45
3	730703	1	PORT 2 - CV2 - P.O. CHECK VALVE P.O. CHECK VALVE, RP08A-01-C-N-15-4
4	730704	1	PORT 8 - CV1 - CHECK VALVE CHECK VALVE, RV08A-01-C-N-05
5	730705	1	PORT 5.1 - SV5 - MAIN BRUSHES DOWN SOL. VALVE, WK08L-01-C-N-0
6	730706	1	PORT 1 - SV7 - SQUEEGEE UP-DN SOL. VALVE, WK08X-01-C-N-0
7	730707	1	PORT 3.1 - SV6 - MAIN BRUSHES UP-LOCK SOL. VALVE, WS08ZR-01-C-N-0
8	730708	1	PORT 3.2 - SV3 - MAIN BRUSHES ON-OFF SOL. VALVE, WS10ZR-01-C-N-0
9	730709	1	PORT 7.1 - SV2 - ALL OFF SOL. VALVE, WS10Y-01-C-N-0
10	730710	1	PORT 6.1 - SV4 - BRUSH FORCE PROP. RED. VALVE, PDR08-01-M-C-N-070
11	731121	1	MANIFOLD BLOCK, MAIN C961-1
12	731122	5	COIL, 12V, 3003124
13	731226	1	COIL, PROPORTIONAL, 12PL-2.2-40-1836

ENGINE MOUNT GROUP - DIESEL (730128)

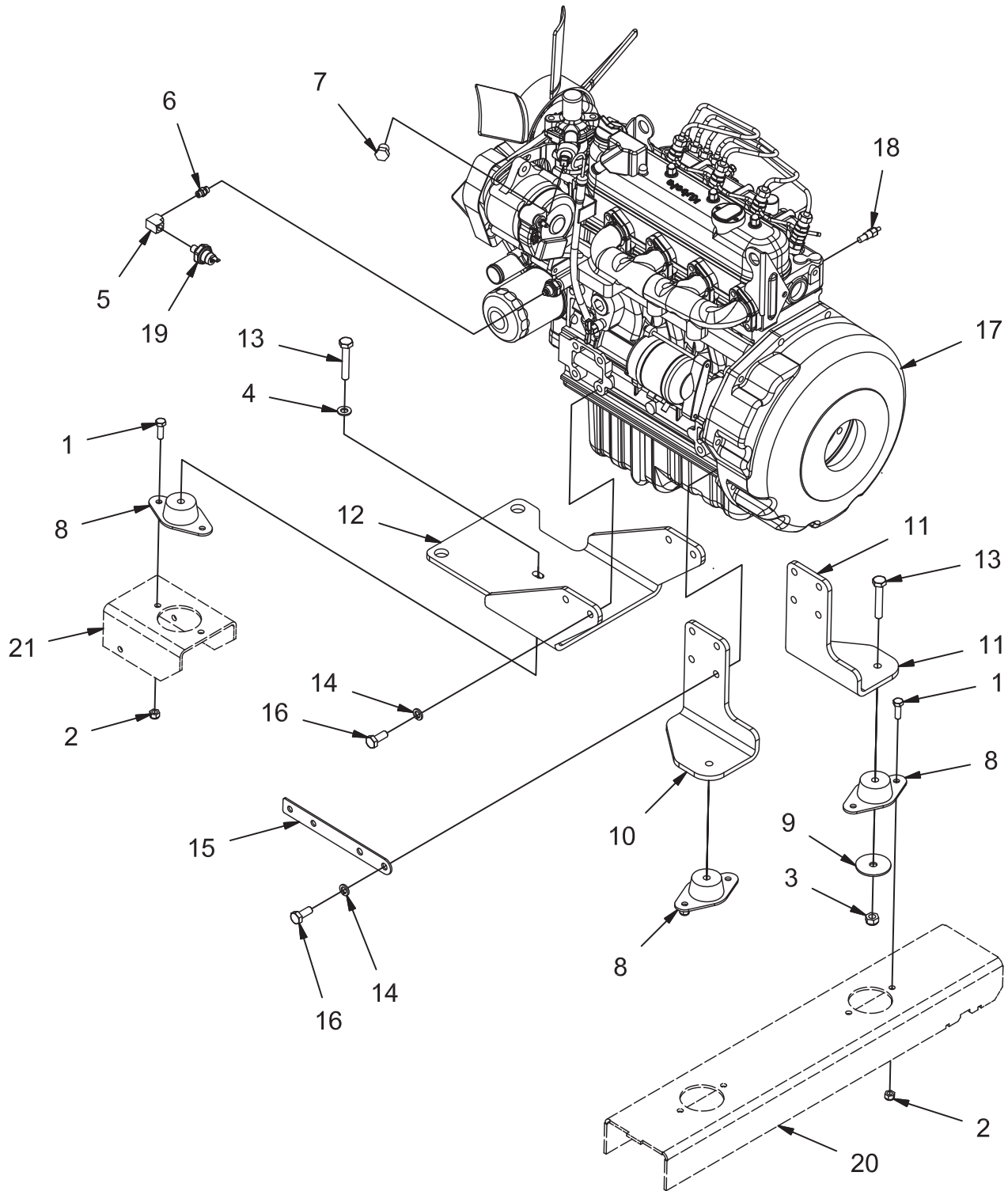

REV A

ENGINE MOUNT GROUP - DIESEL (730128)

Parts List 730128			
ITEM	PART NUMBER	QTY	DESCRIPTION
1	11038247	6	BLT-HH M8-1.25 X 25 STL ZINC
2	12040051	6	NUT, M8-1.25 ESN
3	12040069	3	NUT, M10-1.50 ESN
4	12310058	1	WASHER, M10
5	3301720	1	FTG, BRASS ELBOW, 1/8 FEMALE NPT
6	3305640	1	FITTING, NIPPLE
7	3400194	1	PIPE PLUG, BRASS, 3/8
8	600212	3	ISOLATOR, VIBRATION
9	600333	3	WASHER, SAFETY
10	600881	1	MOUNT, REAR OUTER DIESEL ENG
11	600882	1	MOUNT, REAR INNER DIESEL ENG
12	600899	1	MOUNT, FRONT DIESEL ENG
13	600925	3	BOLT, M10-1.50 X 60 HH
14	600945	12	LOCK WASHER, M10
15	620081	1	MOUNT, HARNESS
16	620082	12	BOLT, M10-1.25 X 25 HH ZP
17	620234F	1	ENGINE, DSL, KUBOTA V1505
18	PART OF 620234	1	SWITCH, WATER TEMP (603000)
19	PART OF 620234	1	SWITCH, OIL PRESSURE (603001)
20	REF.	-	FRAME
21	REF.	-	FRAME
22	748535	1	HARNESS ASSY, ENGINE GROUND

ENGINE MOUNT GROUP - GAS (730164)

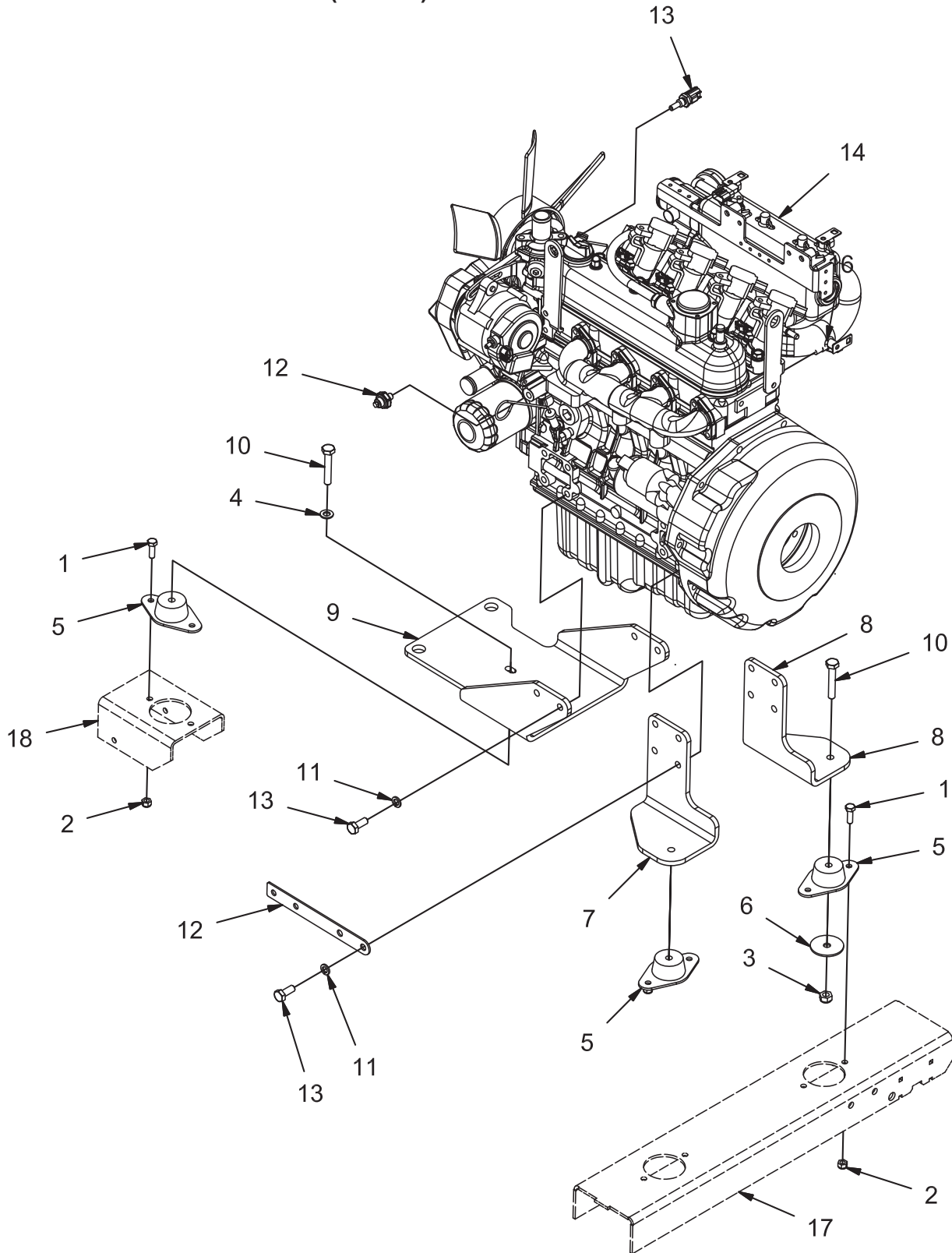

REV B

ENGINE MOUNT GROUP - GAS (730164)

Parts List 730164			
ITEM	PART NUMBER	QTY	DESCRIPTION
1	11038247	6	BLT-HH M8-1.25 X 25 STL ZINC
2	12040051	6	NUT, M8-1.25 ESN
3	12040069	3	NUT, M10-1.50 ESN
4	12310058	1	WASHER, M10
5	600212	3	ISOLATOR, VIBRATION
6	600333	3	WASHER, SAFETY
7	600881	1	MOUNT, REAR OUTER DIESEL ENG
8	600882	1	MOUNT, REAR INNER DIESEL ENG
9	600899	1	MOUNT, FRONT DIESEL ENG
10	600925	3	BOLT, M10-1.50 X 60 HH
11	600945	12	LOCK WASHER, M10
12	620081	1	MOUNT, HARNESS
13	620082	12	BOLT, M10-1.25 X 25 HH ZP
14	620700	1	KUBOTA GAS ENGINE
15	PART OF 620236	1	SWITCH, OIL PRESSURE (603001)
16	PART OF 620236	1	SWITCH, WATER TEMP (603000)
17	REF.	-	FRAME
18	REF.	-	FRAME
19	748535	1	HARNESS ASSY, ENGINE GROUND

ENGINE MOUNT GROUP - LPG (730163)

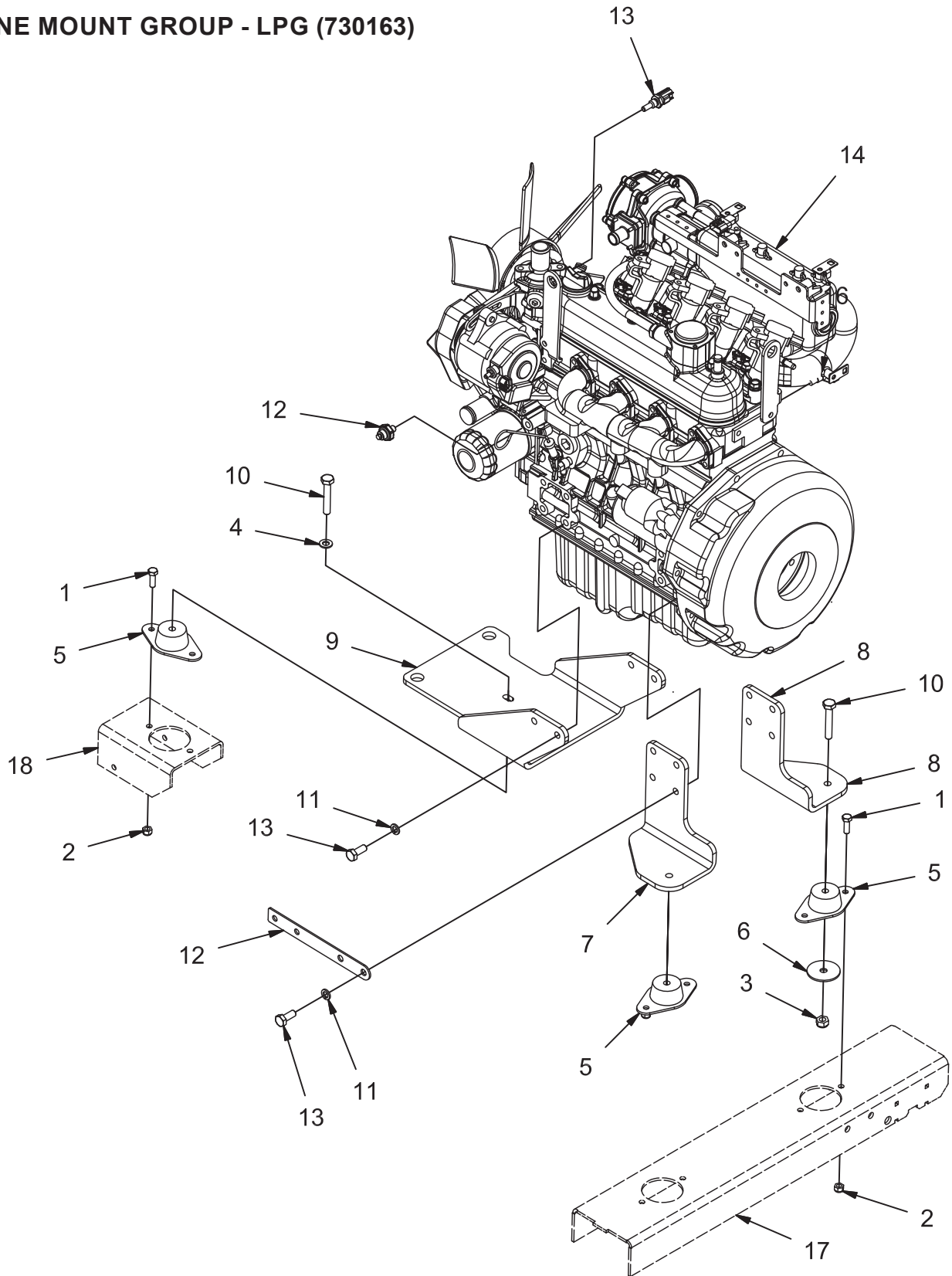

REV B

ENGINE MOUNT GROUP - LPG (730163)

Parts List 730163			
ITEM	PART NUMBER	QTY	DESCRIPTION
1	11038247	6	BLT-HH M8-1.25 X 25 STL ZINC
2	12040051	6	NUT, M8-1.25 ESN
3	12040069	3	NUT, M10-1.50 ESN
4	12310058	1	WASHER, M10
5	600212	3	ISOLATOR, VIBRATION
6	600333	3	WASHER, SAFETY
7	600881	1	MOUNT, REAR OUTER DIESEL ENG
8	600882	1	MOUNT, REAR INNER DIESEL ENG
9	600899	1	MOUNT, FRONT DIESEL ENG
10	600925	3	BOLT, M10-1.50 X 60 HH
11	600945	12	LOCK WASHER, M10
12	620081	1	MOUNT, HARNESS
13	620082	12	BOLT, M10-1.25 X 25 HH ZP
14	620699	1	KUBOTA ENGINE - LPG A/N (CAT MUFFLER)
15	PART OF 620235	1	SWITCH, OIL PRESSURE (603001)
16	PART OF 620235	1	SWITCH, WATER TEMP (603000)
17	REF.	-	FRAME
18	REF.	-	FRAME
19	748535	1	HARNESS ASSY, ENGINE GROUND

AIR CLEANER GROUP - DIESEL (730131)

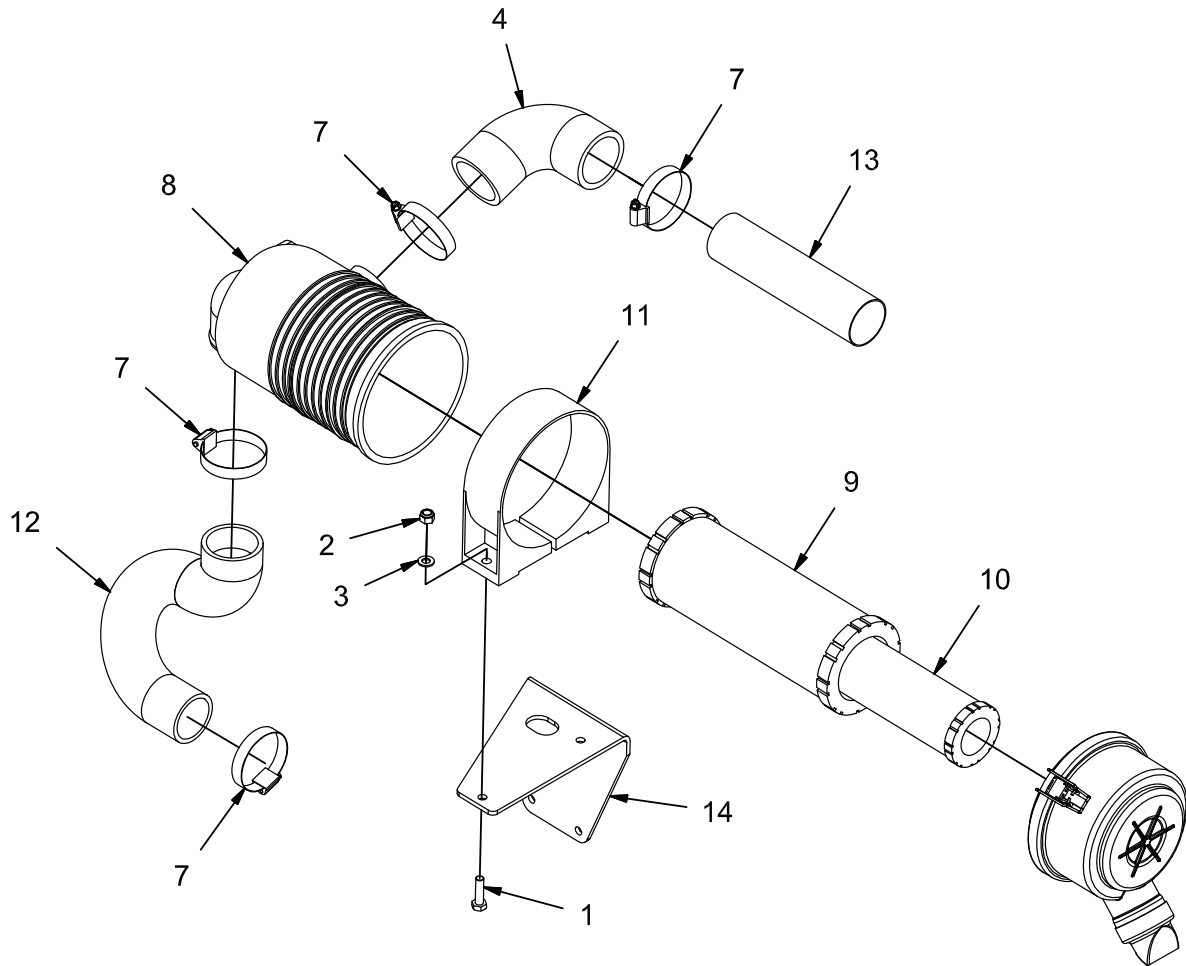

REV A

AIR CLEANER GROUP - DIESEL (730131)

Parts List 730131			
ITEM	PART NUMBER	QTY	DESCRIPTION
1	11038254	2	BOLT, M8-125 X 30 HH
2	12040051	2	NUT, M8-1.25 ESN
3	12310041	2	WASHER, M8
4	3300396	1	ADAPTER, 2" 90
5	3303991	1	INDICATOR, FLTR SERVICE
6	3305640	1	FITTING, NIPPLE
7	3312189	4	CLAMP, HOSE, 2.00
8	3317917	1	HOUSING, AIR FLTR
9	3321143	1	ELEMENT, FLTR, PRIMARY
10	3322572	1	ELEMENT, FLTR, SAFETY
11	600385	1	MOUNTING BAND, AIR CLEANER
12	730319	1	HOSE, AIR INTAKE, DIESEL
13	730393	1	TUBE, AIR CLEANER INTAKE
14	731188	1	MOUNT, AIR CLEANER

AIR CLEANER GROUP - GAS (730129)

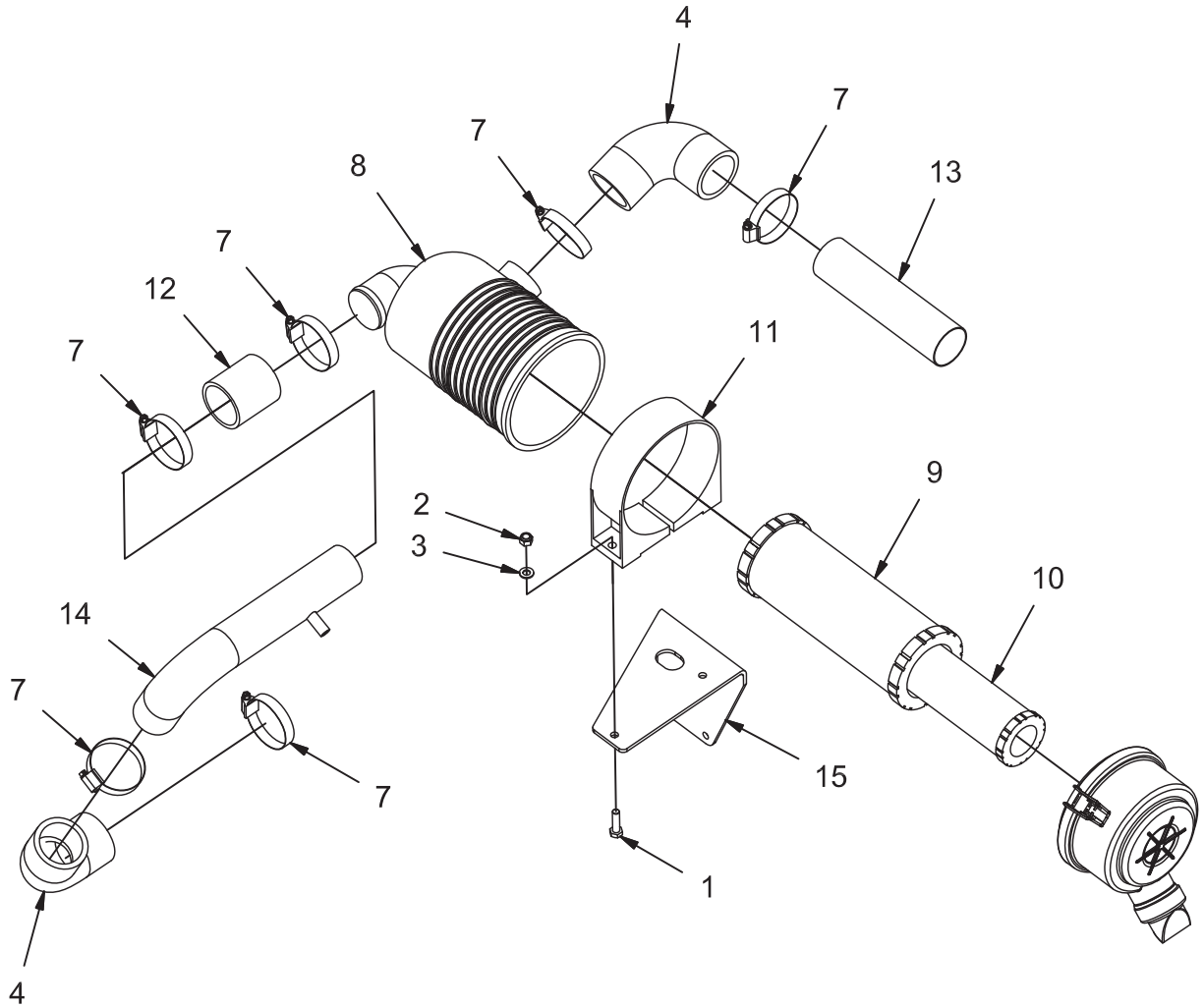

REV C

AIR CLEANER GROUP - GAS (730129)

Parts List 730129			
ITEM	PART NUMBER	QTY	DESCRIPTION
1	11038254	2	BOLT, M8-125 X 30 HH
2	12040051	2	NUT, M8-1.25 ESN
3	12310041	2	WASHER, M8
4	3300396	2	ADAPTER, 2" 90
5	3303991	1	INDICATOR, FLTR SERVICE
6	3305640	1	FITTING, NIPPLE
7	3312189	6	CLAMP, HOSE, 2.00
8	3317917	1	HOUSING, AIR FLTR
9	3321143	1	ELEMENT, FLTR, PRIMARY
10	3322572	1	ELEMENT, FLTR, SAFETY
11	600385	1	MOUNTING BAND, AIR CLEANER
12	730056	1	HOSE, 2.00 X 3.00
13	730393	1	TUBE, AIR CLEANER INTAKE
14	731110	1	WELDMENT, GAS AIR INTAKE
15	731188	1	MOUNT, AIR CLEANER

AIR CLEANER GROUP - LPG (730130)

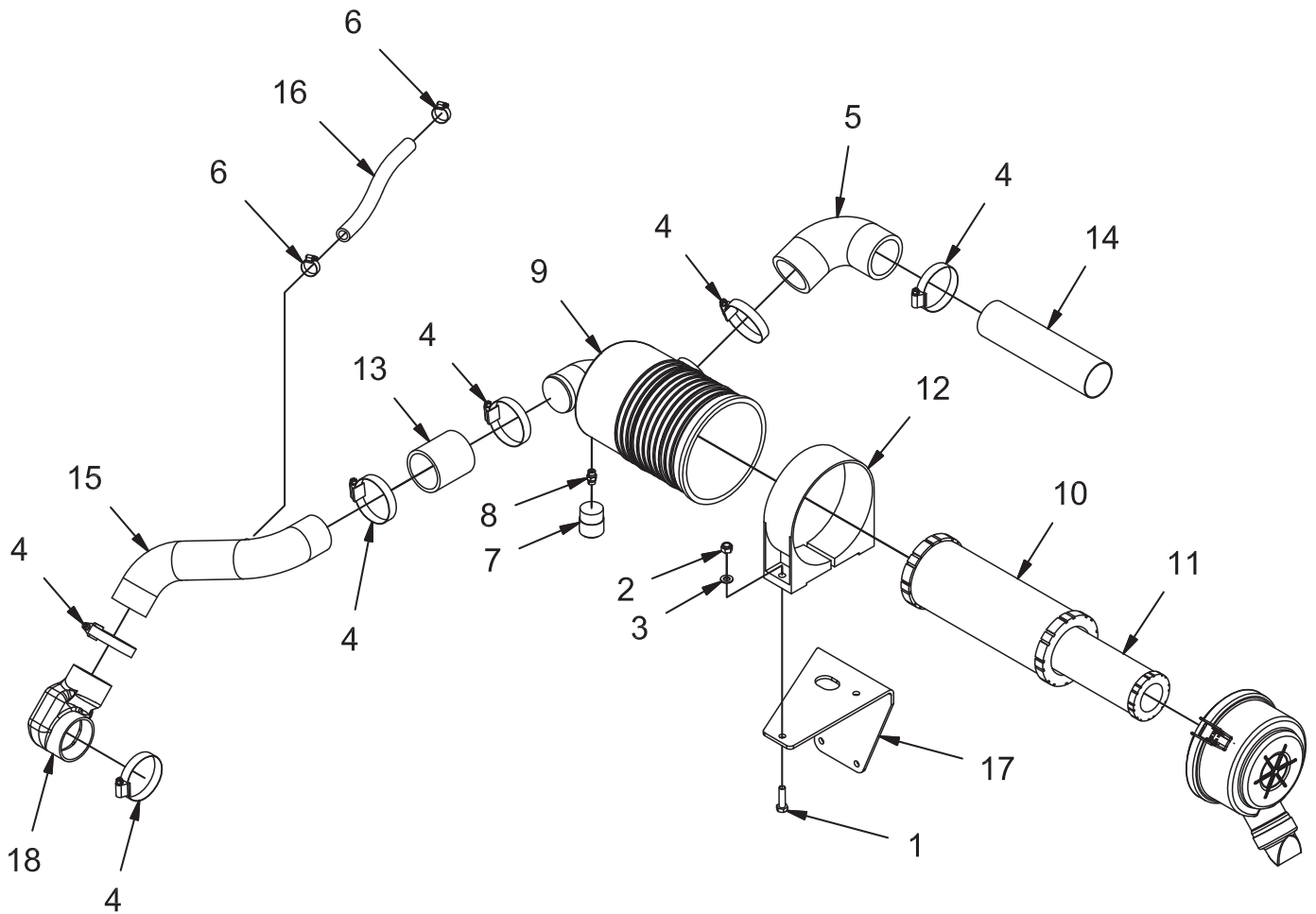

REV D

AIR CLEANER GROUP - LPG (730130)

Parts List 730130			
ITEM	PART NUMBER	QTY	DESCRIPTION
1	11038254	2	BOLT, M8-125 X 30 HH
2	12040051	2	NUT, M8-1.25 ESN
3	12310041	2	WASHER, M8
4	3044112	6	CLAMP, HOSE
5	3300396	1	ADAPTER, 2" 90
6	3300535	2	CLAMP, HOSE, .50
7	3303991	1	INDICATOR, FLTR SERVICE (INCLUDES 3305640)
8	3305640	1	FITTING, NIPPLE (SERVICE PART)
9	3317917	1	HOUSING, AIR FLTR (INCLUDES FILTER ELEMENTS)
10	3321143	1	ELEMENT, FLTR, PRIMARY (SERVICE PART)
11	3322572	1	ELEMENT, FLTR, SAFETY (SERVICE PART)
12	600385	1	MOUNTING BAND, AIR CLEANER
13	730056	1	HOSE, 2.00 X 3.00
14	730393	1	TUBE, AIR CLEANER INTAKE
15	731128	1	WELDMENT, LPG AIR INTAKE
16	731175	1	PCV HOSE
17	731188	1	MOUNT, AIR CLEANER
18	620662	1	COBRA AIR CUFF

RADIATOR GROUP (730132)

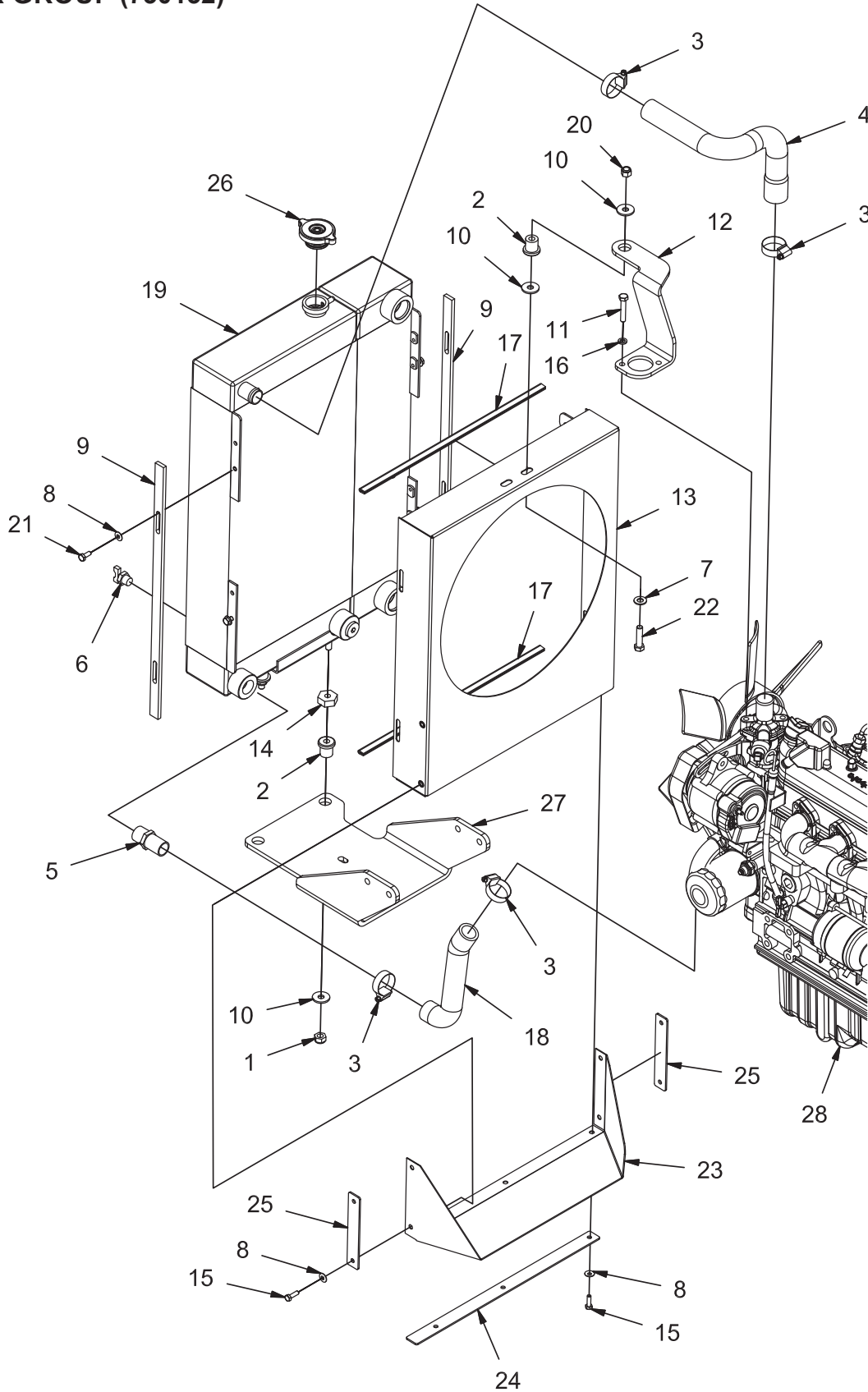

REV D

RADIATOR GROUP (730132)

Parts List 730132			
ITEM	PART NUMBER	QTY	DESCRIPTION
1	12040069	2	NUT, M10-1.50 ESN
2	3300465	3	ISOLATOR, VIB
3	3302193	4	CLAMP, HOSE, .75 - 1.25
4	3332643	1	HOSE, UPPER RAD, DIESEL
5	3344231	1	FITTING, RADIATOR
6	3344232	1	PETCOCK
7	3400087	1	WASHER, 3/8
8	3400383	11	WASHER, 1/4 BELLEVILLE
9	600198	2	SPACER, SHROUD
10	600363	4	WASHER, ISOLATOR
11	600820	2	BOLT, M8-1.25 X 45 HH
12	600867	1	MOUNT, UPPER SHROUD, DIESEL
13	600875-1	1	ASSEMBLY, FAN SHROUD, DIESEL
14	600884	2	SPACER, ISOLATOR
15	600913	7	BOLT, M6-1.00 X 20 HH SS
16	600959	2	LOCK WASHER, M8
17	620064	2	SEAL, SHROUD
18	690020	1	HOSE, LOWER RADIATOR
19	690125	1	RADIATOR - OIL COOLER
20	711380	1	NUT, FIBER INSERT 3/8-16
21	713001	4	SCREW, 1/4-20 X .625 HHC
22	713044	1	SCREW, 3/8-16 X 1.50 HHC
23	731580	1	SHIELD
24	731581	1	RETAINER, BOTTOM
25	731582	2	RETAINER, SIDE
26	PART OF 3336679	1	RADIATOR CAP
27	REF	-	FRONT ENGINE MOUNT
28	REF.	-	ENGINE, DIESEL

RADIATOR OVERFLOW BOTTLE GROUP (730133)

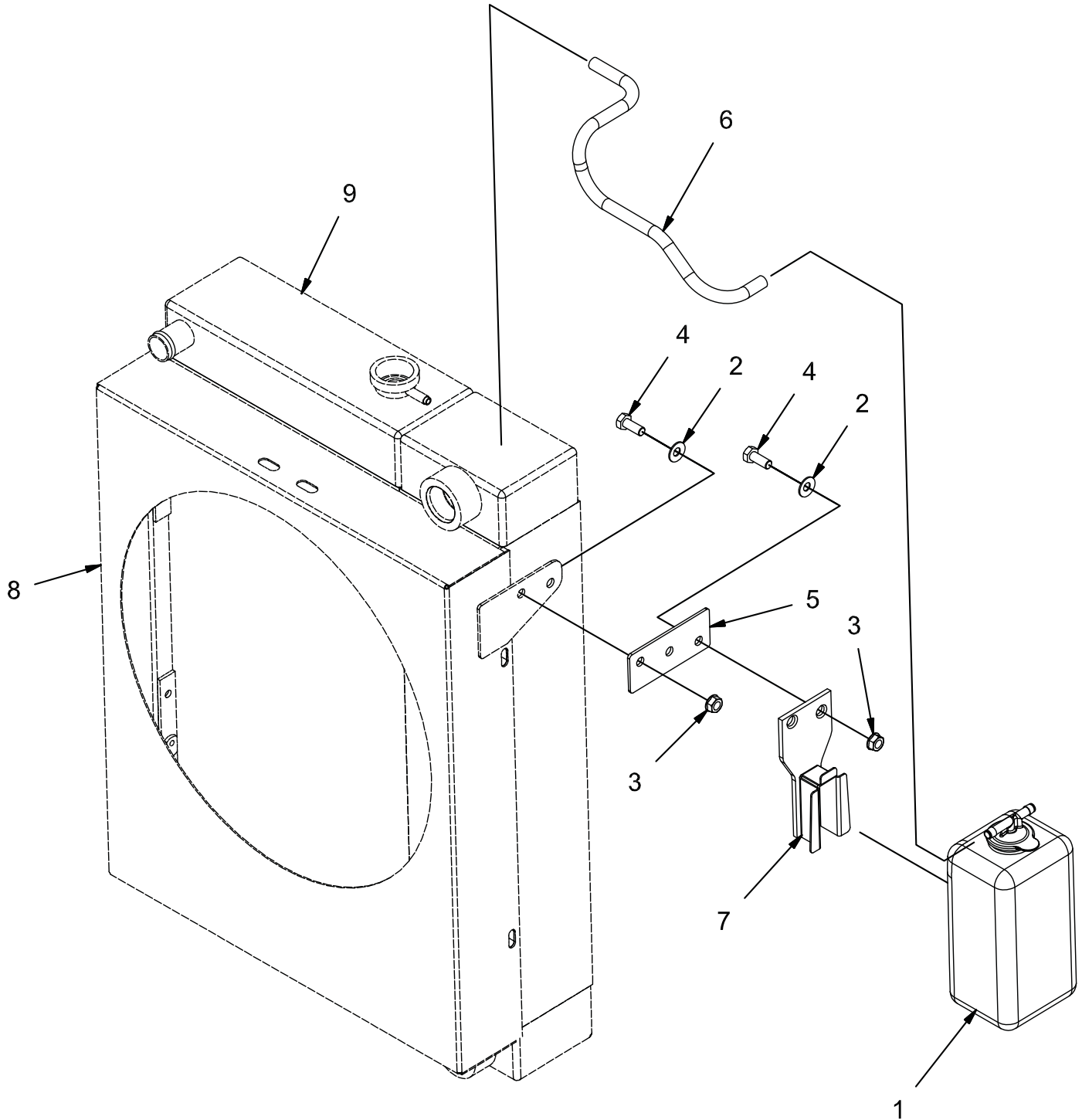

REV A

RADIATOR OVERFLOW BOTTLE GROUP (730133)

Parts List 730133			
ITEM	PART NUMBER	QTY	DESCRIPTION
1	3318752	1	OVERFLOW BOTTLE
2	3400384	3	WASHER, 5/16 BELLEVILLE
3	600934	3	NUT, M8-1.25 FLNG
4	717024	3	BOLT, M8-1.25 X 20 HH
5	731165	1	MOUNT, OVERFLOW BOTTLE
6	PART OF 3318752	1	HOSE, OVERFLOW
7	PART OF 3318752	1	BRACKET, BOTTLE
8	REF.	-	FAN SHROUD, DIESEL
9	REF.	-	RADIATOR

OIL COOLER GROUP (730134)

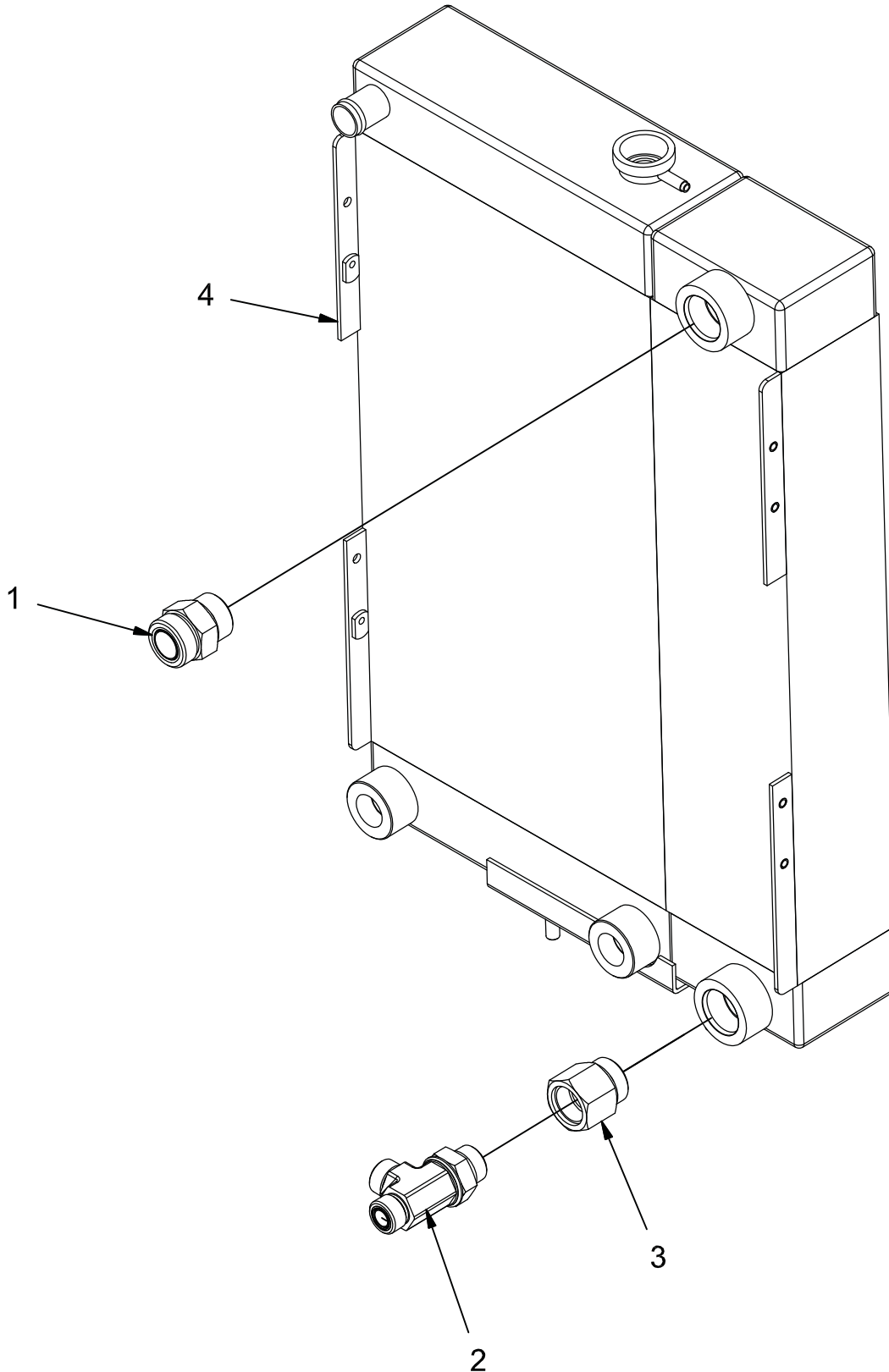

REV *

OIL COOLER GROUP (730134)

Parts List			
ITEM	PART NUMBER	QTY	DESCRIPTION
1	675505	1	FITTING, STR, 16 ORFS - 16 SAE
2	675554	1	FITTING, TEE, 10 ORFS - 12 SAE
3	675558	1	FITTING, REDUCER, 16 O-RING TO 12 O-RING
4	REF	-	RADIATOR - OIL COOLER

EXHAUST GROUP - DIESEL (730154)

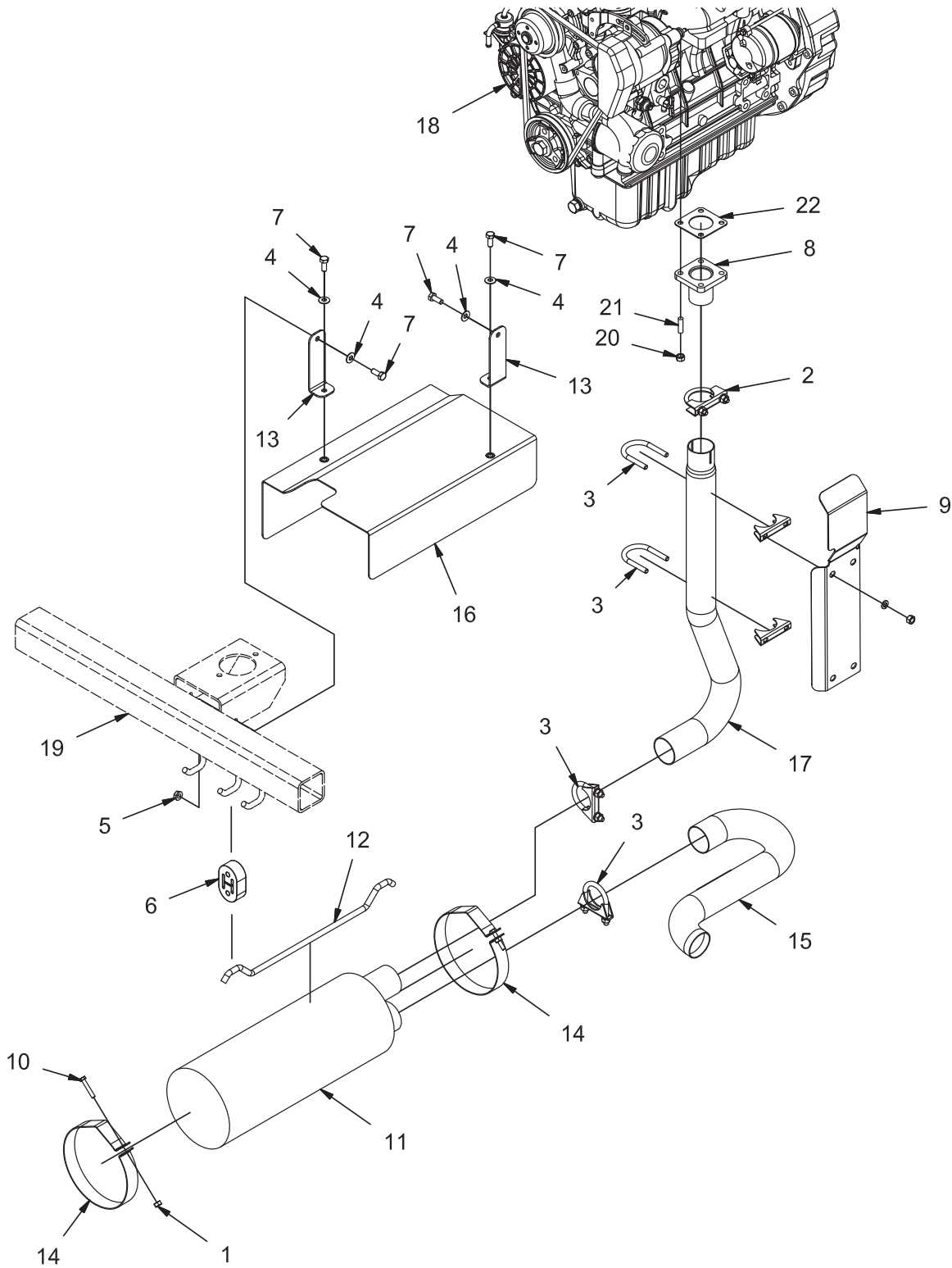

REV E

EXHAUST GROUP - DIESEL (730154)

Parts List - 730154			
ITEM	PART NUMBER	QTY	DESCRIPTION
1	12022042	2	NUT, M6-1.00 HEX
2	3301640	1	CLAMP, 1.75
3	3302917	4	CLAMP, EXHAUST, 2 IN
4	3400384	4	WASHER, 5/16 BELLEVILLE
5	600934	1	NUT, M8-1.25 FLNG
6	620205	1	EXHAUST ISOLATOR
7	717024	4	BOLT, M8-1.25 X 20 HH
8	730409	1	WELDMENT, EXHAUST STUB
9	730419	1	HEAT SHIELD
10	730508	2	BOLT, M6-1.00 X 35 HH FULL THREAD SS
11	731177	1	MUFFLER
12	731178	1	HANGER, MUFFLER
13	731179	2	MOUNT, HEAT SHIELD
14	731180	2	STRAP, MUFFLER
15	731219	1	TAIL PIPE
16	731220-1	1	ASSEMBLY, HEAT SHIELD - DIESEL
17	731222	1	EXHAUST PIPE - DIESEL
18	REF.	-	ENGINE
19	REF.	-	FRAME
20	WITH ENGINE	4	NUT, M8-1.25 SS
21	WITH ENGINE	4	STUD, M8-1.25
22	WITH ENGINE	1	GASKET, EXHAUST

EXHAUST GROUP - GAS / LP (730178)

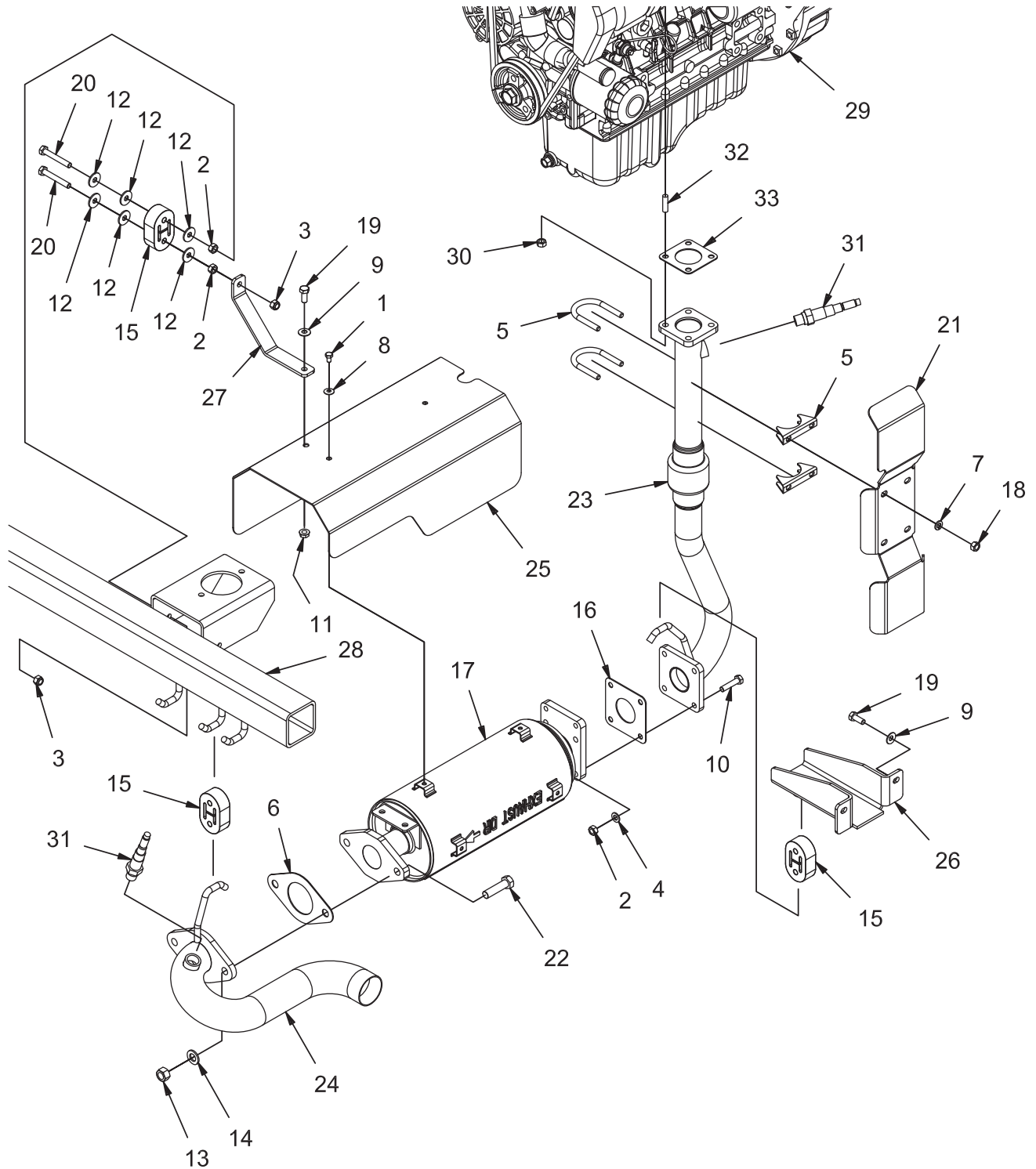

REV B

EXHAUST GROUP - GAS / LP (730178)

Parts List 730178			
ITEM	PART NUMBER	QTY	DESCRIPTION
1	11038056	2	BOLT, M6-1.00 X 10 HH ZP
2	12022059	6	NUT, M8-1.25
3	12040051	2	NUT, M8-1.25 ESN
4	12310041	4	WASHER, M8
5	3301641	2	CLAMP, EXHAUST
6	3345028	1	GASKET - CAT 3605
7	3400102	4	LOCK WASHER, 5/16 HS MED
8	3400383	2	WASHER, 1/4 BELLEVILLE
9	3400384	3	WASHER, 5/16 BELLEVILLE
10	600918	4	BOLT, M8-125 X 35 HH
11	600934	1	NUT, M8-1.25 FLNG
12	600940	6	WASHER, M8 FENDER
13	600949	2	NUT, M12-1.75
14	600950	2	WASHER, M12
15	620205	3	EXHAUST ISOLATOR
16	690190	1	GASKET, CATALYST, 4-BOLT
17	690191	1	CATALYTIC CONVERTER, LPG - GAS
18	711319	4	NUT, HEX 5/16-18
19	717024	3	BOLT, M8-1.25 X 20 HH
20	730507	2	BOLT, M8-1.25 X 55 HH SS
21	730665	1	HEAT SHIELD
22	730667	2	BOLT, M12-1.75 X 45 HH
23	731327	1	WELDMENT, EXHAUST PIPE, GAS - LPG
24	731328	1	WELDMENT, EXHAUST PIPE
25	731432	1	HEAT SHIELD
26	731465	1	WELDMENT, EXHAUST HANGER
27	731483	1	BAR, HANGER
28	REF.	-	FRAME, ENG TUBE
29	REF.	-	ENGINE
30	WITH ENGINE	4	NUT, M8-1.25 SS
31	WITH ENGINE	2	O2 SENSOR
32	WITH ENGINE	4	STUD, M8-1.25
33	WITH ENGINE	1	GASKET, EXHAUST

FUEL TANK MOUNT GROUP - DIESEL (730140)

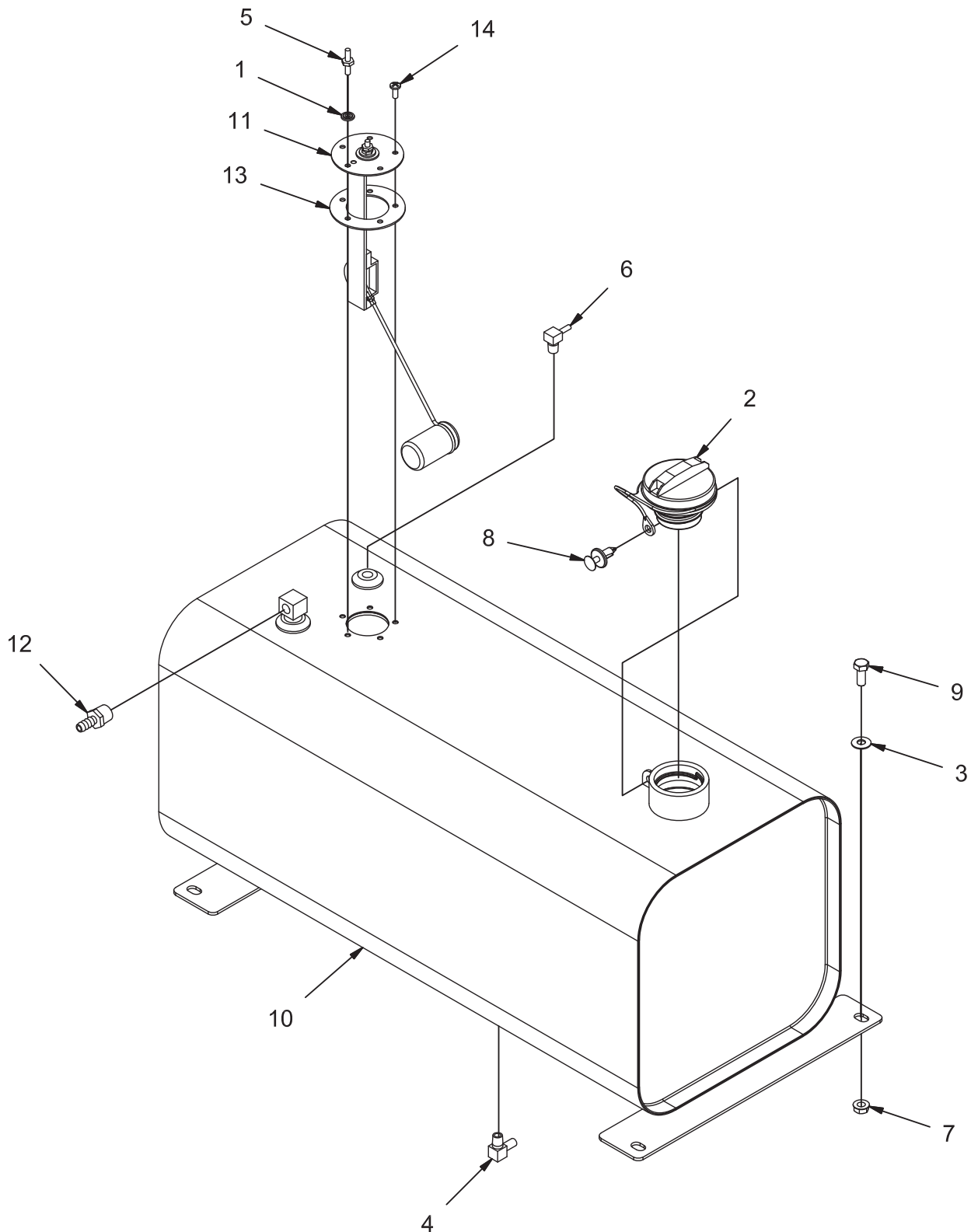

REV D

FUEL TANK MOUNT GROUP - DIESEL (730140)

Parts List 730140			
ITEM	PART NUMBER	QTY	DESCRIPTION
1	3337019	1	SEAL, #10
2	3343413	1	CAP, FUEL TANK
3	3400384	4	WASHER, 5/16 BELLEVILLE
4	3401445	1	FITTING, 90, 1/4 NPT X 5/16 BARB
5	3401579	1	SCREW, HEX, STANDOFF, 2X #10-32 X .50
6	3402022	1	FITTING, 90, 1/4 NPT X .184 BARB
7	600934	4	NUT, M8-1.25 FLNG
8	600965	1	FASTENER, PRESS-IN
9	717024	4	BOLT, M8-1.25 X 20 HH
10	730313	1	TANK, FUEL
11	730322	1	SENDING UNIT, FUEL LEVEL
12	731387	1	FITTING, 3/8 NPT - 5/16 HOSE BARB
13	PART OF 730322	1	GASKET
14	PART OF 730322	4	SCREW #10-32 X .50

FUEL TANK MOUNT GROUP - GAS (730139)

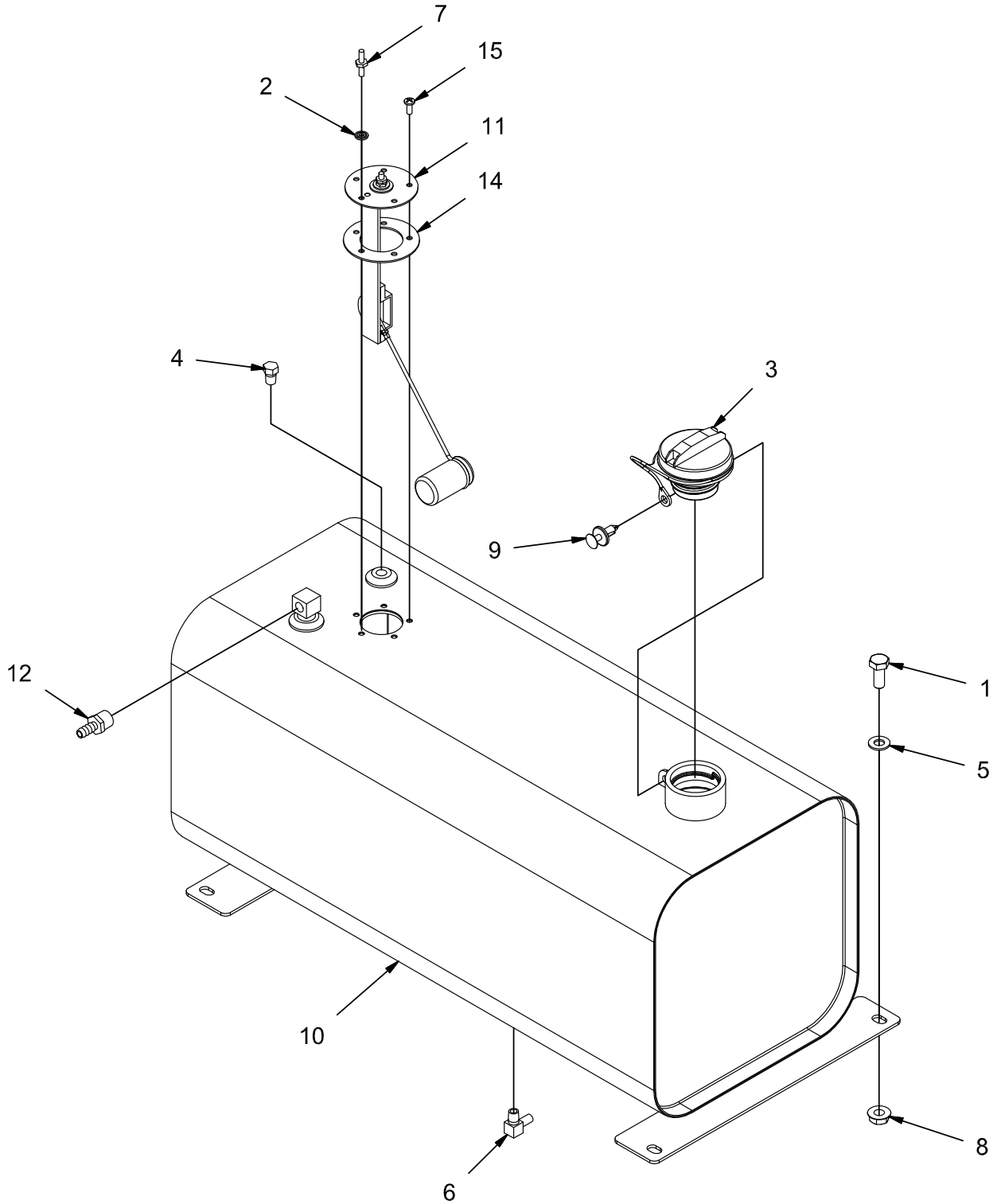

REV C

FUEL TANK MOUNT GROUP - GAS (730139)

Parts List 730139			
ITEM	PART NUMBER	QTY	DESCRIPTION
1	11038346	4	BOLT, M10-1.50 X 25 HH
2	3337019	1	SEAL, #10
3	3343413	1	CAP, FUEL TANK
4	3400256	1	PLUG, 1/4 NPT
5	3400385	4	WASHER, 3/8, BELLEVILLE
6	3401445	1	FITTING, 90, 1/4 NPT X 5/16 BARB
7	3401579	1	SCREW, HEX, STANDOFF, 2X #10-32 X .50
8	600936	4	NUT, M10-1.50 FLNG
9	600965	1	FASTENER, PRESS-IN
10	730313	1	TANK, FUEL
11	730322	1	SENDING UNIT, FUEL LEVEL
12	731387	1	FITTING, 3/8 NPT - 5/16 HOSE BARB
13	748990-1	1	HARNESS, FUEL PUMP
14	PART OF 730322	1	GASKET
15	PART OF 730322	4	SCREW #10-32 X .50

LPG TANK MOUNT GROUP (730138)

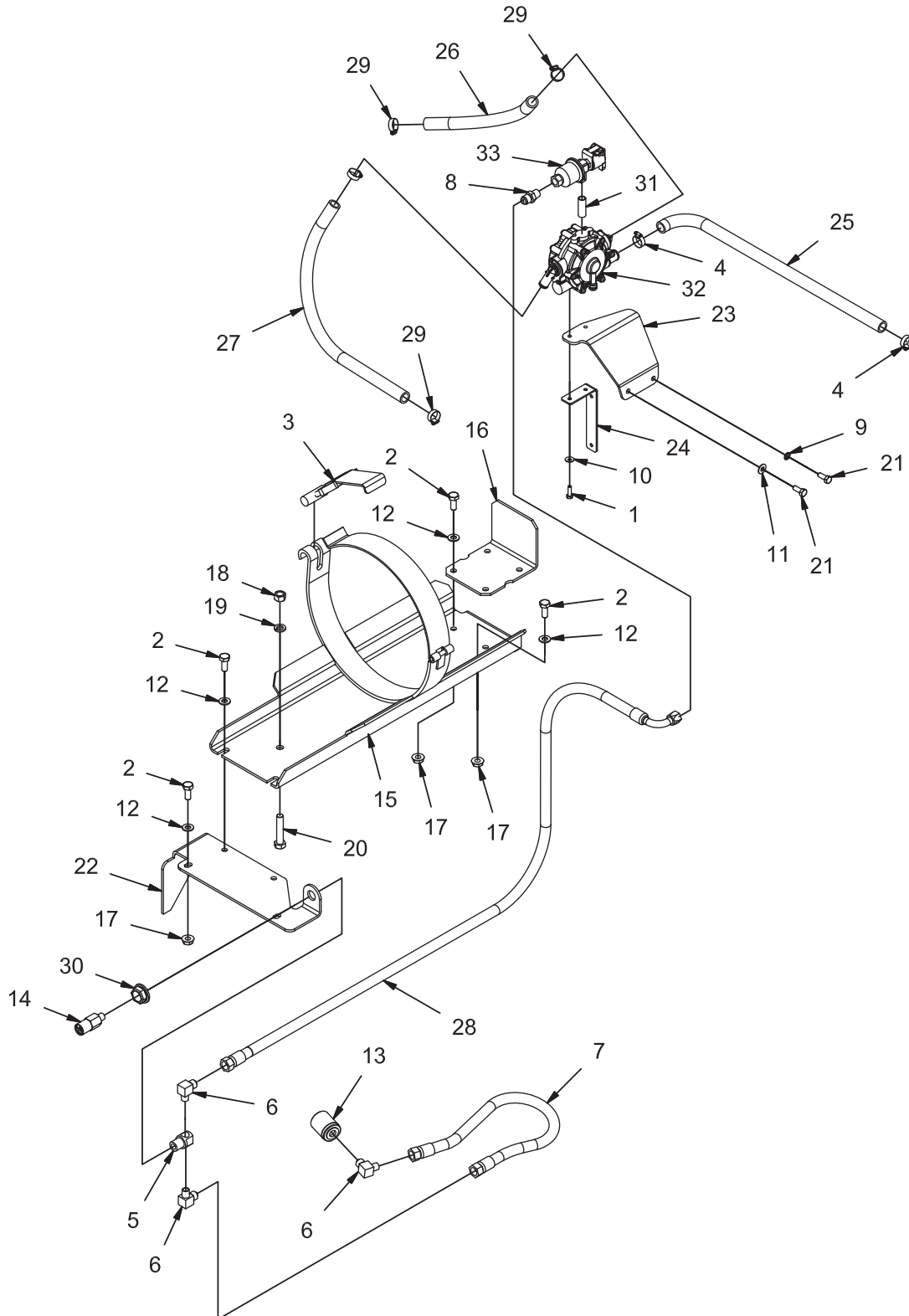

REV G

LPG TANK MOUNT GROUP (730138)

Parts List - 730138			
ITEM	PART NUMBER	QTY	DESCRIPTION
1	11038098	2	BOLT, M6-100 X 20 HH
2	11038346	8	BOLT, M10-1.50 X 25 HH
3	220131	1	BUCKLE
4	3300535	2	CLAMP, HOSE, .50
5	3316511	1	BODY, VALVE MOUNT
6	3334037	3	FITTING, 90, BRASS, LPG
7	3335375	1	HOSE, LPG, TO TANK
8	3342097	1	FTG SAE 5/8-18 45 DEGREE FLARE
9	3400273	1	WASHER, STAR, .31, INT. ZP
10	3400383	2	WASHER, 1/4 BELLEVILLE
11	3400384	1	WASHER, 5/16 BELLEVILLE
12	3400385	8	WASHER, 3/8, BELLEVILLE
13	3400860	1	FTG-LP TANK CONNECT
14	3400862	1	LPG RELIEF VALVE
15	600459-1	1	WELDMENT, LPG MNT
16	600461-1	1	ANGLE, LPG STOP
17	600936	8	NUT, M10-1.50 FLNG
18	600949	1	NUT, M12-1.75
19	600961	1	LOCK WASHER, M12
20	620036	1	BOLT, M12-1.75 X 60 HH FULL THREAD
21	717024	2	BOLT, M8-1.25 X 20 HH
22	730533	1	MOUNT, LPG VALVE
23	730890	1	BRACKET, VAPORIZER
24	731164	1	MOUNT, FUSE BOX
25	731167	1	HOSE, VAPORIZER TO CARB
26	731173	1	HOSE, COOLANT, 5/8" ID X 15.0" LG
27	731174	1	HOSE, COOLANT, 5/8" ID X 43.0" LG
28	731186	1	HOSE, LPG TANK TO VAPORIZER
29	829129	4	CLAMP, HOSE
30	PART OF 3316511	1	NUT, VALVE MOUNT
31	PART OF ENGINE	1	FITTING, NIPPLE
32	PART OF ENGINE	1	VAPORIZER (13098-62401)
33	PART OF ENGINE	1	SOLENOID AND LOCK OFF (EG523-46951)

CE LPG TANK MOUNT GROUP (730138-CE)

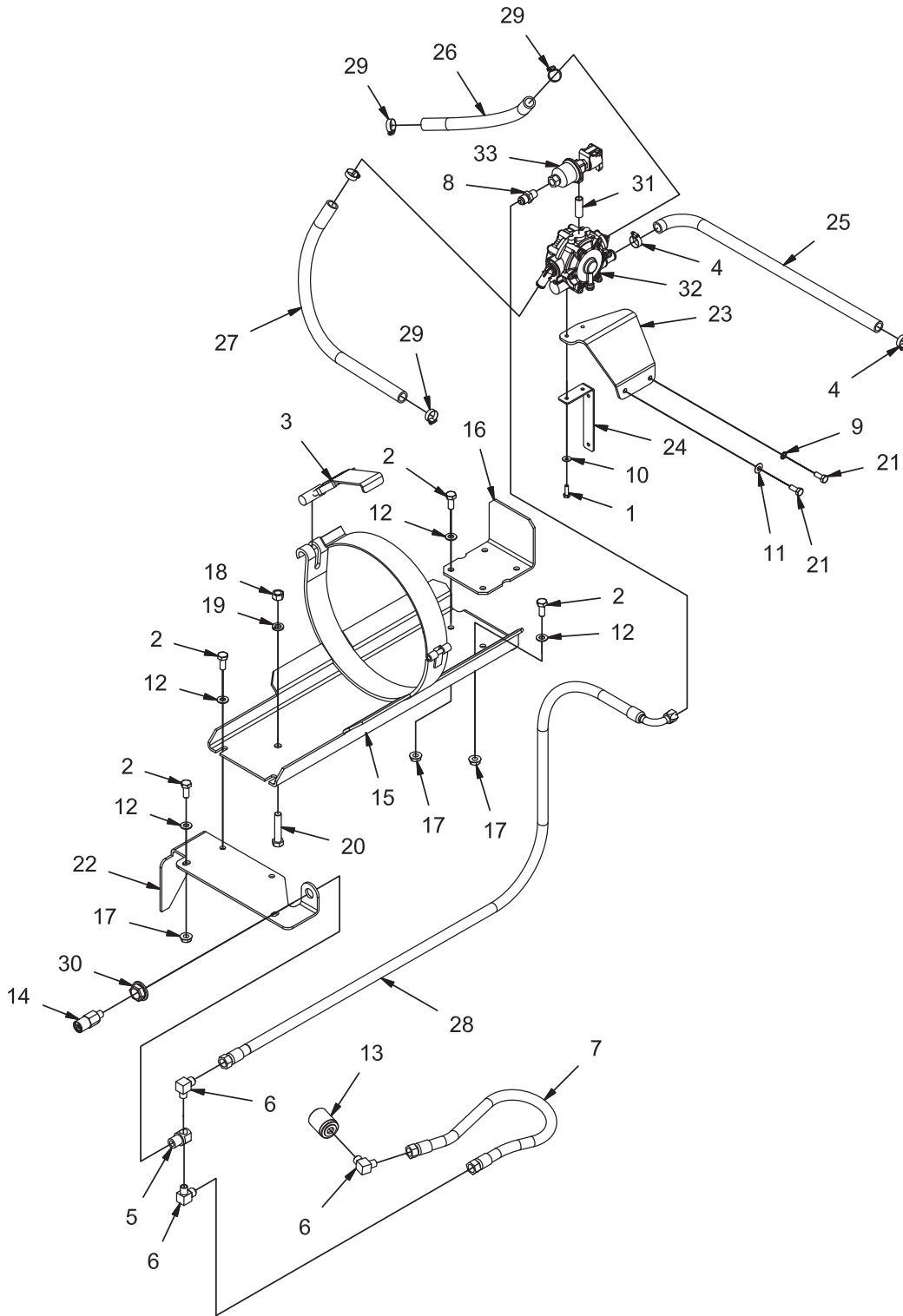

REV B

CE LPG TANK MOUNT GROUP (730138-CE)

Parts List - 730138-CE			
ITEM	PART NUMBER	QTY	DESCRIPTION
1	11038098	2	BOLT, M6-100 X 20 HH
2	11038346	8	BOLT, M10-1.50 X 25 HH
3	220131	1	BUCKLE
4	3300535	2	CLAMP, HOSE, .50
5	3316511	1	BODY, VALVE MOUNT
6	3334037	3	FITTING, 90, BRASS, LPG
7	3335375-CE	1	HOSE, LPG, TO TANK
8	3342097	1	FTG SAE 5/8-18 45 DEGREE FLARE
9	3400273	1	WASHER, STAR, .31, INT. ZP
10	3400383	2	WASHER, 1/4 BELLEVILLE
11	3400384	1	WASHER, 5/16 BELLEVILLE
12	3400385	8	WASHER, 3/8, BELLEVILLE
13	3400860	1	FTG-LP TANK CONNECT
14	3400862	1	LPG RELIEF VALVE
15	600459-1	1	WELDMENT, LPG MNT
16	600461-1	1	ANGLE, LPG STOP
17	600936	8	NUT, M10-1.50 FLNG
18	600949	1	NUT, M12-1.75
19	600961	1	LOCK WASHER, M12
20	620036	1	BOLT, M12-1.75 X 60 HH FULL THREAD
21	717024	2	BOLT, M8-1.25 X 20 HH
22	730533	1	MOUNT, LPG VALVE
23	730890	1	BRACKET, VAPORIZER
24	731164	1	MOUNT, FUSE BOX
25	731167-CE	1	HOSE, VAPORIZER TO CARB
26	731173	1	HOSE, COOLANT, 5/8" ID X 15.0" LG
27	731174	1	HOSE, COOLANT, 5/8" ID X 43.0" LG
28	731186-CE	1	HOSE, LPG TANK TO VAPORIZER
29	829129	4	CLAMP, HOSE
30	PART OF 3316511	1	NUT, VALVE MOUNT
31	PART OF ENGINE	1	FITTING, NIPPLE
32	PART OF ENGINE	1	VAPORIZER (13098-62401)
33	PART OF ENGINE	1	SOLENOID AND LOCK OFF (EG523-46951)

FUEL LINE GROUP - DIESEL (730153)

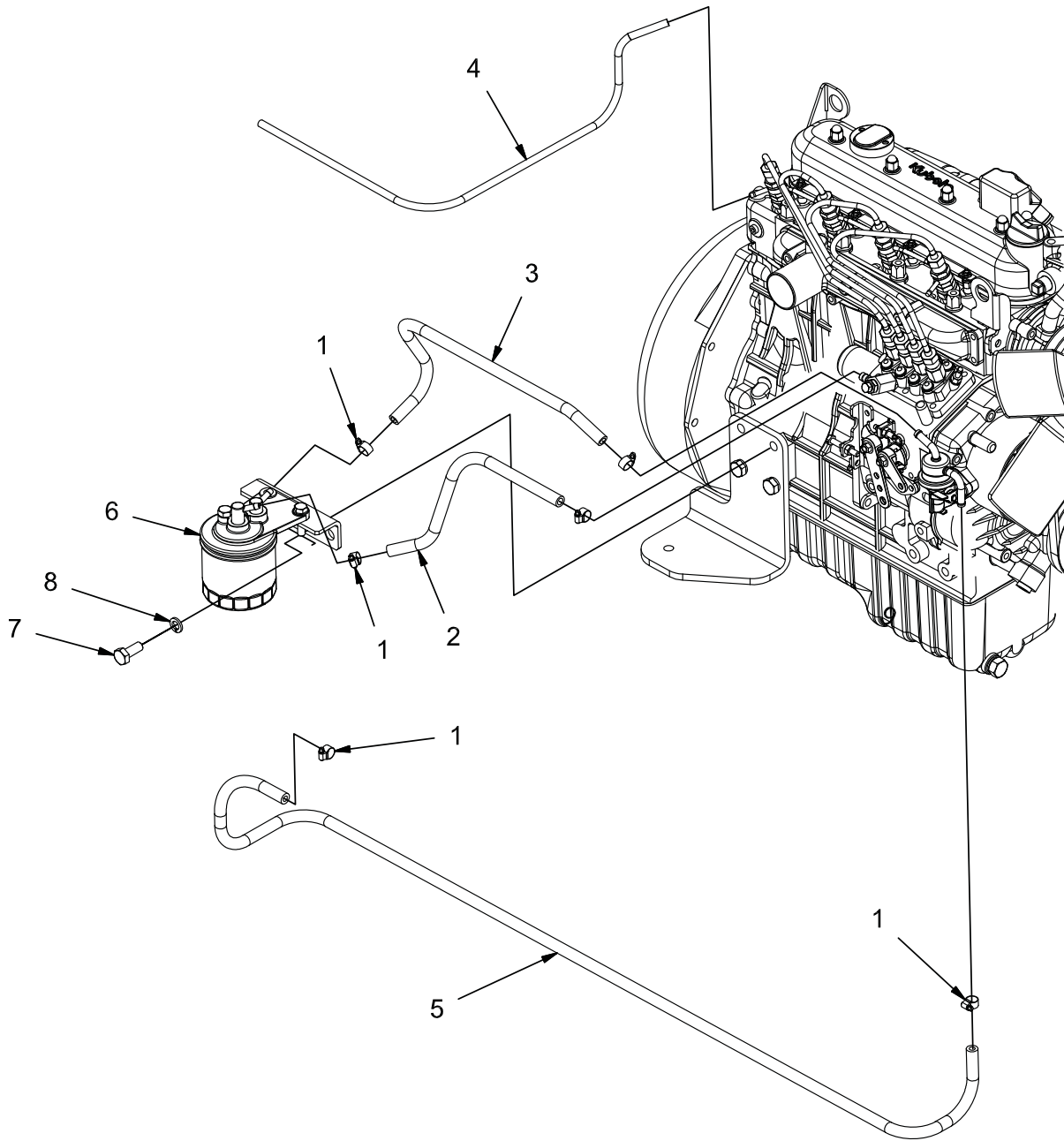

REV *

FUEL LINE GROUP - DIESEL (730153)

Parts List - 730153			
ITEM	PART NUMBER	QTY	DESCRIPTION
1	3302338	6	CLAMP, HOSE, .50
2	620001	1	HOSE,FUEL, 5/16 ID 12.00 LG, SAE30R7
3	620061	1	HOSE,FUEL, 5/16 ID 18.00 LG, SAE30R7
4	NO DWG	1	HOSE, FUEL, 1/8 ID SAE30R7
5	NO DWG	1	HOSE, FUEL, 5/16 ID SAE30R7
6	PART OF ENGINE	-	FUEL FILTER ASSEMBLY
7	REF.	-	BOLT, M10-1.50 X 25 HH
8	REF.	-	LOCK WASHER, M10
9	REF.	-	ENGINE, DIESEL

FUEL COMPONENT GROUP - GAS (730141)

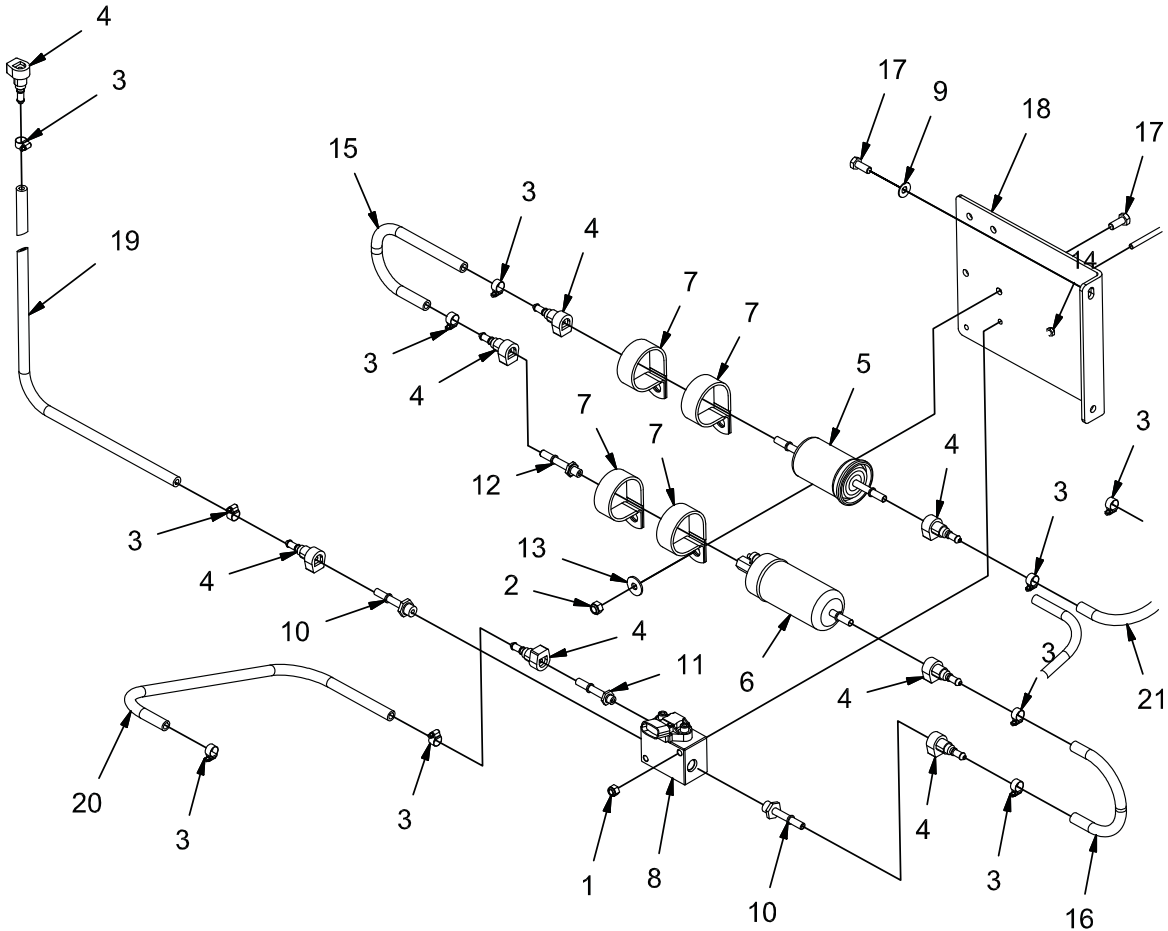

REV *

FUEL COMPONENT GROUP - GAS (730141)

Parts List 730141			
ITEM	PART NUMBER	QTY	DESCRIPTION
1	12040044	2	NUT, M6-1.00 ESN
2	12040051	4	NUT, M8-1.25 ESN
3	3302338	10	CLAMP, HOSE, .50
4	3342207	8	FITTING, ADAPTER, FUEL
5	3342209	1	FILTER, FUEL
6	3343536	1	PUMP, FUEL
7	3343539	4	CLAMP, 2"
8	3343617	1	MANIFOLD, FUEL PRESS/TEMP
9	3400384	2	WASHER, 5/16 BELLEVILLE
10	3401088	2	FTG-ADAPTER, FUEL 1/2-20 W/O-RING
11	3401089	1	FTG-ADAPTER, FUEL 3/8-24 W/O-RING
12	3401090	1	FITTING & GASKET FOR FUEL PUMP
13	600940	4	WASHER, M8 FENDER
14	600953	2	BOLT, M6-1.00 X 50 HH
15	620001	1	HOSE,FUEL, 5/16 ID X 12.00 LG, SAE30R7
16	620002	1	HOSE,FUEL, 5/16 ID X 10.00 LG, SAE30R7
17	717024	6	BOLT, M8-1.25 X 20 HH
18	730311	1	MOUNT, FUEL FILTER
19	TBD	1	HOSE,FUEL, 5/16 ID SAE30R7 (TO ENGINE)
20	TBD	1	HOSE,FUEL, 5/16 ID SAE30R7 (FUEL RETURN)
21	TBD	1	HOSE,FUEL, 5/16 ID SAE30R7 (FROM TANK)

THROTTLE SOLENOID GROUP - DIESEL (730151)

Parts List - 730151			
ITEM	PART NUMBER	QTY	DESCRIPTION
1	11038247	1	BLT-HH M8-1.25 X 25 STL ZINC
2	11038353	1	BOLT, M10-1.50 X 20 HH
3	12040051	1	NUT, M8-1.25 ESN
4	3335303	1	SOLENOID, THROTTLE
5	3335358	1	BRACKET, THROTTLE SOLENOID
6	3335364	1	PLT, KBA V1505 DSL SOLENOID THROTTLE
7	3342225	1	BALL JOINT, 1/4-28 STD LG
8	3400089	4	WASHER, 1/4 .625 X .281 X .063
9	3400180	1	NUT, 1/4-28
10	3400373	1	NUT, LOW HEIGHT 1/4-28 ESN
11	3401071	1	BUSHING, FLNG, .312 ID X .50 OD X .375
12	3401458	1	LOCK WASHER, M10
13	600918	1	BOLT, M8-125 X 35 HH
14	600959	2	LOCK WASHER, M8
15	711374	1	NUT, FIBER INSERT 5/16-18
16	711373	4	NUT, FIBER INSERT 1/4-20
17	713002	4	SCREW, 1/4-20 X .750 HHC
18	713027	1	SCREW, 5/16-18 X 1.000 HHM
19	REF.	-	ENGINE, DIESEL

BATTERY GROUP (730142)

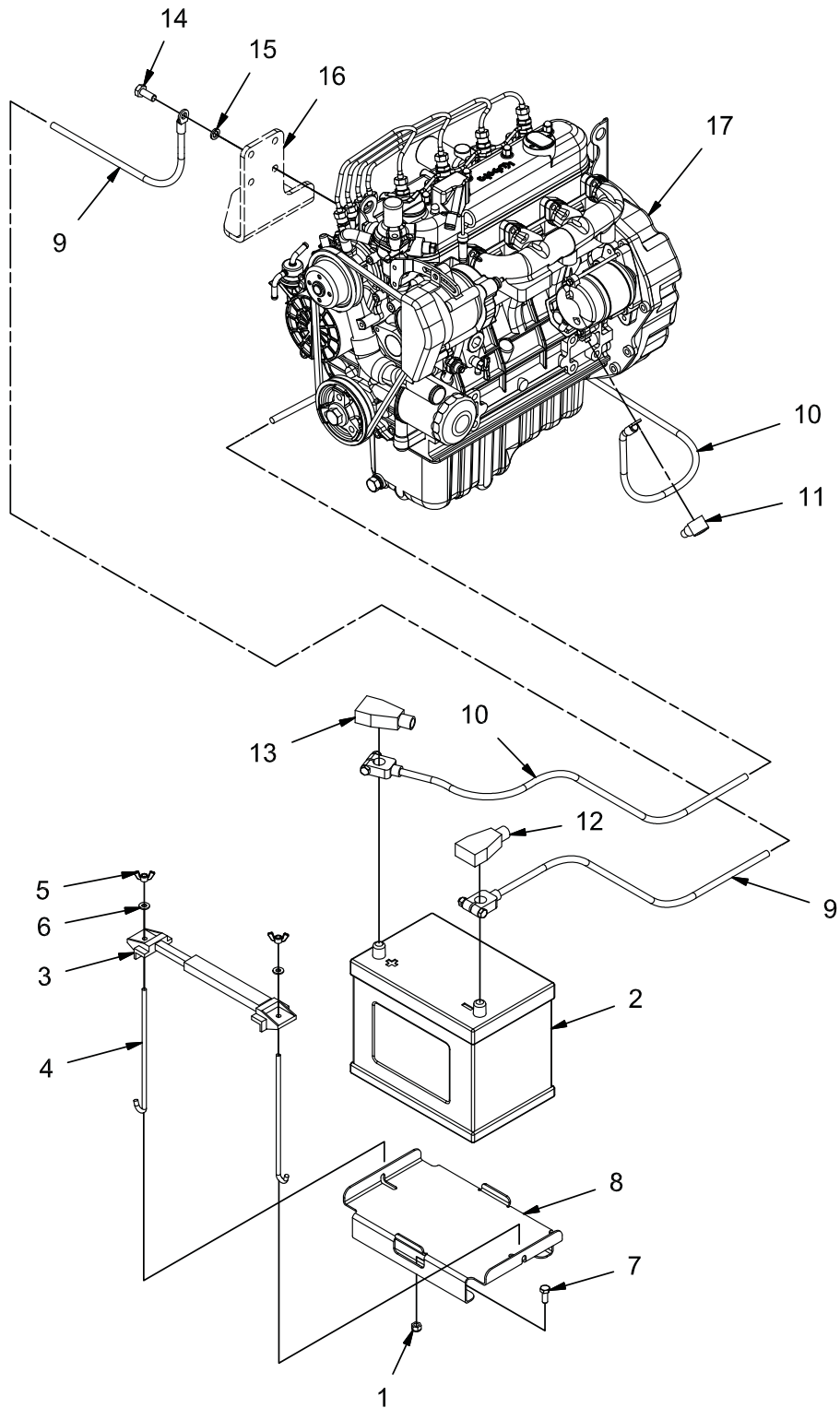

REV A

BATTERY GROUP (730142)

Parts List 730142			
ITEM	PART NUMBER	QTY	DESCRIPTION
1	12040051	2	NUT, M8-1.25 ESN
2	3300440	1	BATTERY, 12V
3	3301076	1	HOLD DOWN, BATTERY
4	3301079	2	ROD, BATTERY TIE DOWN
5	3400085	2	WING NUT, 1/4-20 ZP
6	3400089	2	WASHER, 1/4 .625 X .281 X .063
7	717024	2	BOLT, M8-1.25 X 20 HH
8	730390	1	TRAY, BATTERY
9	748993	1	CABLE, BATTERY, NEG
10	748994	1	CABLE, BATTERY, POS
11	742740	1	BOOT, TERM, RED
12	PART OF CABLE	1	BOOT, BATTERY, BLACK
13	PART OF CABLE	1	BOOT, BATTERY, RED
14	REF.	-	BOLT, M10-1.25 X 25 HH ZP
15	REF.	-	LOCK WASHER, M10
16	REF.	-	ENGINE MOUNT
17	REF.	-	ENGINE

FRONT COVER GROUP (730143)

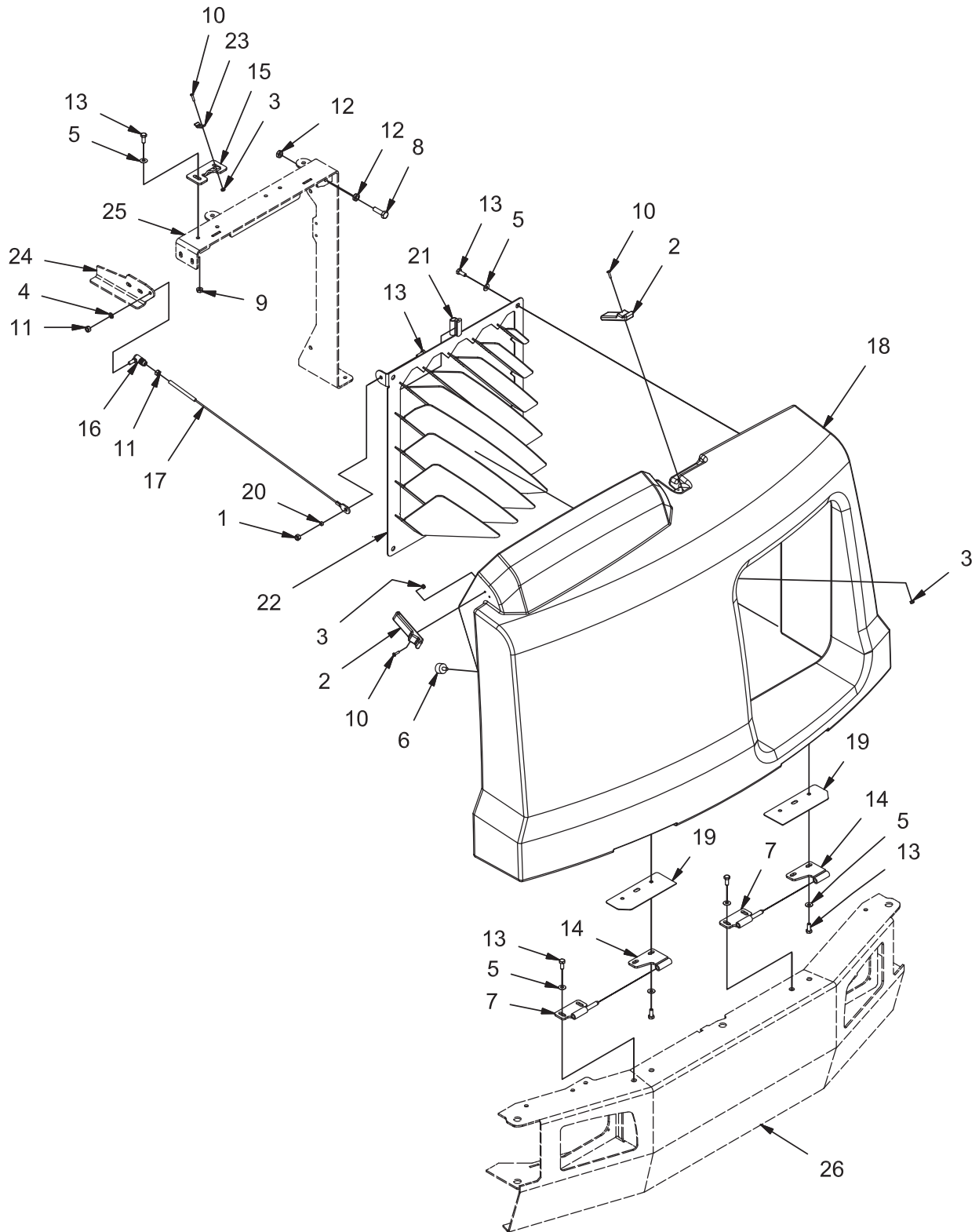

REV E

FRONT COVER GROUP (730143)

Parts List 730143			
ITEM	PART NUMBER	QTY	DESCRIPTION
1	12040051	1	NUT, M8-1.25 ESN
2	3307719	2	DRAW LATCH
3	3400082	6	NUT, FIBER INSERT #8-32
4	3400102	1	LOCK WASHER, 5/16 HS MED
5	3400384	14	WASHER, 5/16 BELLEVILLE
6	600220	1	BUMPER, 1.00 X .625 T
7	600383	2	WELDMENT, HINGE, MALE, LG
8	600924	1	BOLT, M10-1.50 X 35 HH FULL THRD
9	600934	2	NUT, M8-1.25 FLNG
10	710230	6	SCREW, #8-32 X .62 PAN HD
11	711322	2	NUT, HEX 5/16-24 ZP
12	717014	2	NUT, M10-1.50 JAM
13	717024	15	BOLT, M8-1.25 X 20 HH
14	730407	2	WELDMENT, HINGE, FEM
15	730429	1	MOUNT, STRIKER
16	730430	1	BALL JOINT, .312, QUICK RELEASE
17	730431	1	CABLE ASSEMBLY
18	730446	1	FRONT COVER
19	730447	2	COVER, HINGE
20	730448	1	SPACER, .328 B .375 OD .188 T
21	731265	1	EDGING, GRILL
22	731861	1	WELDMENT, GRILLE
23	PART OF 3307719	1	KEEPER
24	REF	-	CONSOLE MTG ANGLE
25	REF	-	COVER FRAME
26	REF	-	FRAME

TOP COVER GROUP (730144)

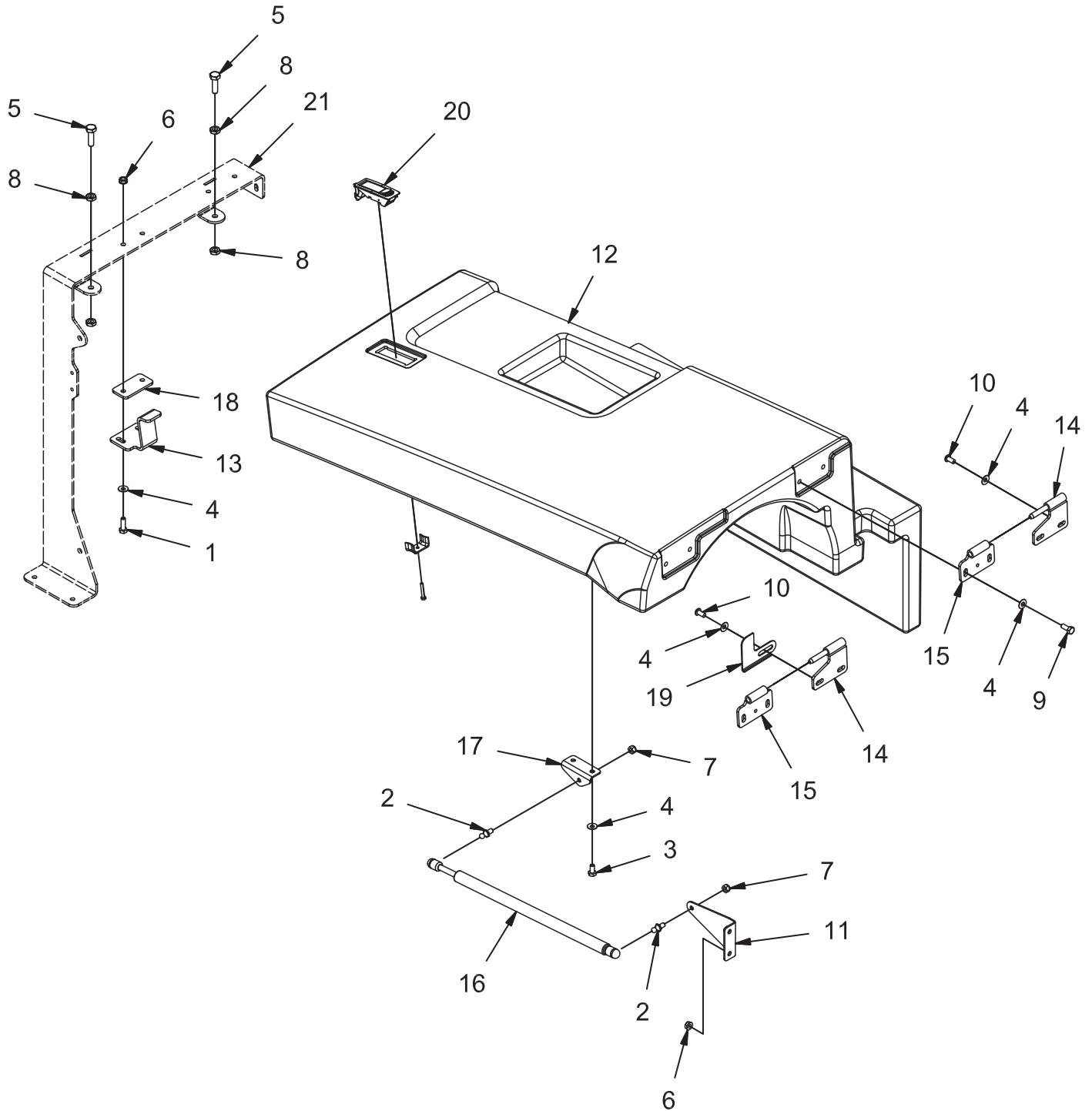

REV F

TOP COVER GROUP (730144)

Parts List 730144			
ITEM	PART NUMBER	QTY	DESCRIPTION
1	11038247	2	BLT-HH M8-1.25 X 25 STL ZINC
2	3300376	2	STUD, 10MM BALL
3	3400291	2	BOLT, M8-1.25 X 16 HH
4	3400384	12	WASHER, 5/16 BELLEVILLE
5	600924	2	BOLT, M10-1.50 X 35 HH FULL THRD
6	600934	4	NUT, M8-1.25 FLNG
7	711374	2	NUT, FIBER INSERT 5/16-18
8	717014	4	NUT, M10-1.50 JAM
9	717024	3	BOLT, M8-1.25 X 20 HH
10	730399	4	SCREW, M8-1.25 X 16 BUTTON HD CAP CZP
11	730433	1	MOUNT, GAS STRUT
12	730450	1	TOP COVER
13	730452	1	STRIKER, TOP COVER
14	730454	2	WELDMENT, HINGE, MALE
15	730456	2	WELDMENT, HINGE, FEM
16	730457L	1	GAS STRUT, LOCKING, 30.9 EXT X 13.8 STK
17	730459	1	ANGLE, GAS STRUT MNT
18	730461	1	BAR, SPACER
19	731132	1	RETAINER, COVER
20	731433	1	LATCH
21	REF	-	COVER FRAME

SIDE DOOR GROUP (730145)

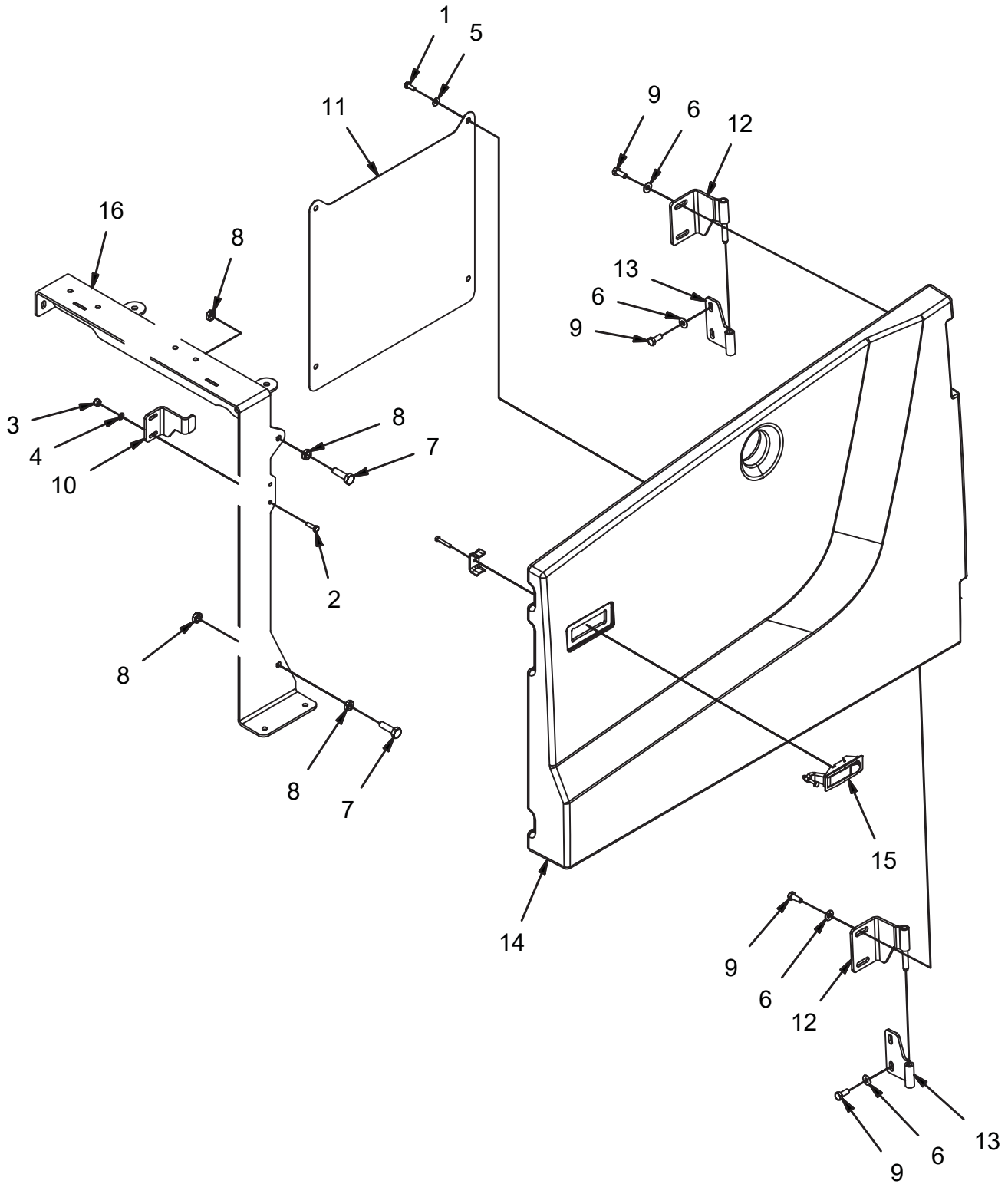

REV B

SIDE DOOR GROUP (730145)

Parts List 730145			
ITEM	PART NUMBER	QTY	DESCRIPTION
1	11038072	4	BOLT, M6-1.00 X 16 HH
2	11038098	2	BOLT, M6-100 X 20 HH
3	12040044	2	NUT, M6-1.00 ESN
4	12310033	2	WASHER, M6
5	3400383	4	WASHER, 1/4 BELLEVILLE
6	3400384	8	WASHER, 5/16 BELLEVILLE
7	600924	2	BOLT, M10-1.50 X 35 HH FULL THRD
8	717014	4	NUT, M10-1.50 JAM
9	717024	8	BOLT, M8-1.25 X 20 HH
10	730403	1	STRIKER, DOOR
11	730404	1	SHIELD, HEAT
12	730405	2	WELDMENT, HINGE, MALE
13	730407	2	WELDMENT, HINGE, FEM
14	730428	1	DOOR, LEFT SIDE
15	731433	1	LATCH
16	REF.	-	COVER FRAME

SEAT DOOR GROUP (730146)

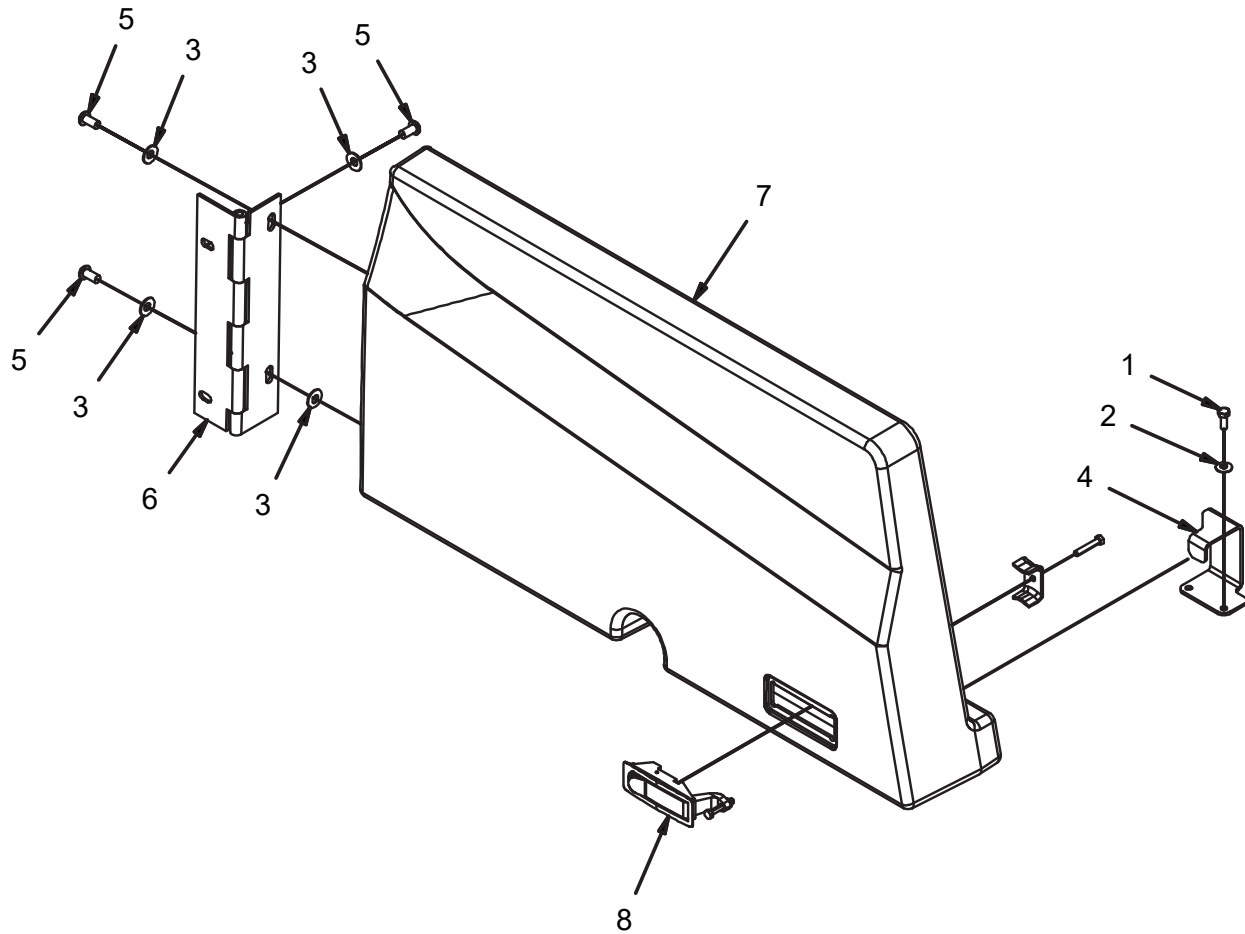

REV B

SEAT DOOR GROUP (730146)

Parts List 730146			
ITEM	PART NUMBER	QTY	DESCRIPTION
1	11038072	2	BOLT, M6-1.00 X 16 HH
2	3400383	2	WASHER, 1/4 BELLEVILLE
3	3400384	5	WASHER, 5/16 BELLEVILLE
4	730398	1	STRIKER, SEAT DOOR
5	730399	4	SCREW, M8-1.25 X 16 BUTTON HD CAP CZP
6	730400	1	HINGE, CONT, 4"
7	730449	1	DOOR, SEAT
8	731433	1	LATCH

SEAT MOUNT GROUP (730147)

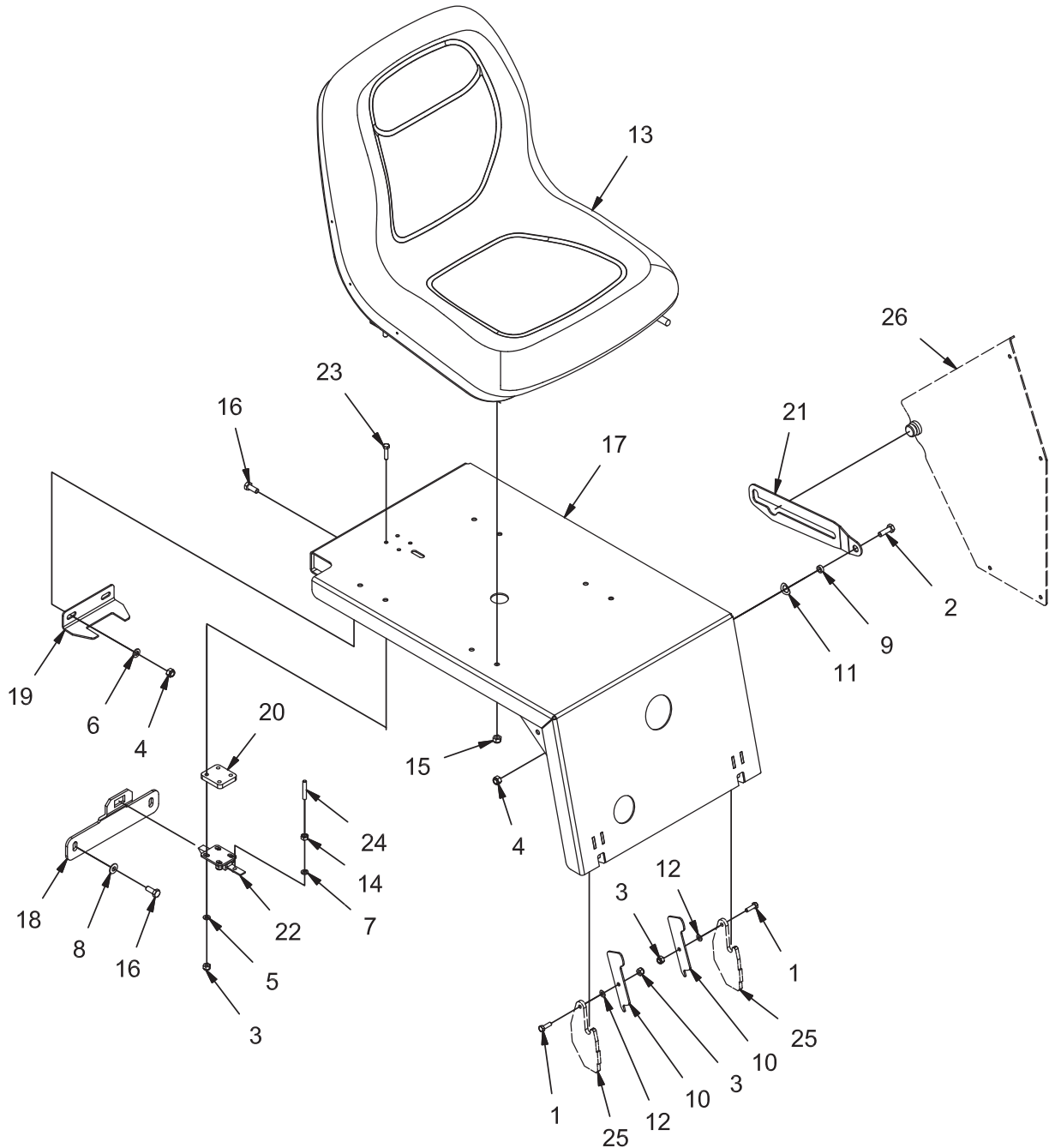

REV D

SEAT MOUNT GROUP (730147)

Parts List 730147			
ITEM	PART NUMBER	QTY	DESCRIPTION
1	11038098	2	BOLT, M6-100 X 20 HH
2	11038247	1	BLT-HH M8-1.25 X 25 STL ZINC
3	12040044	6	NUT, M6-1.00 ESN
4	12040051	3	NUT, M8-1.25 ESN
5	12310033	4	WASHER, M6
6	12310041	2	WASHER, M8
7	173080	1	WASHER-FLAT .266 X .875 X .07 SS
8	3400384	2	WASHER, 5/16 BELLEVILLE
9	600138	1	SPACER, .328 B .500 OD .188 T
10	600194	2	LATCH, COVER
11	600948	1	WASHER, .50 CURVED SPRING
12	600963	2	WASHER, M6, CURVED SPRING
13	620219	1	SEAT
14	711425	1	NUT-FLANGED WIZZ 1/4-20 ZP
15	711374	4	NUT, FIBER INSERT 5/16-18
16	717024	4	BOLT, M8-1.25 X 20 HH
17	730320	1	WELDMENT, SEAT MNT
18	730482	1	BRACKET, SEAT STRIKER
19	730484	1	PLATE, SEAT LOCK
20	730486	1	PLT, SPACER
21	730487	1	SUPPORT, SEAT MNT
22	730488	1	SLIDE LATCH
23	717021	4	SCR-HH M6-1.0 X 30 ZP CLASS 8.8
24	731163	1	ROD, LATCH
25	REF	-	CONSOLE
26	REF	-	COVER PLATE

HYDRAULIC HOSE GROUP (730148)

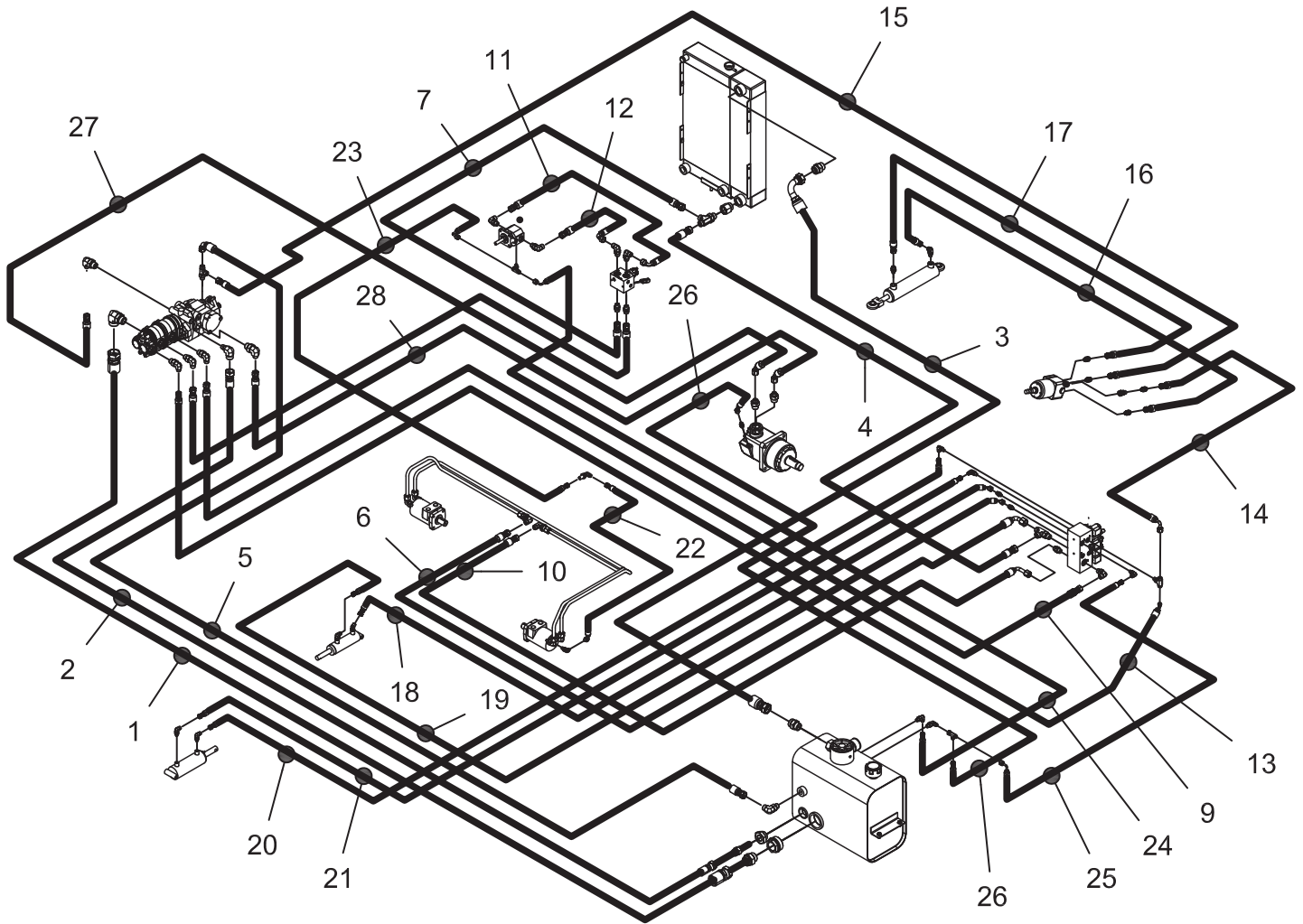

REV C

HYDRAULIC HOSE GROUP (730148)

Parts List 730148			
ITEM	PART NUMBER	QTY	DESCRIPTION
1	731051	1	HOSE, 20 STR - 20 STR SUC (RES TO AUX PUMP IN)
2	731052	1	HOSE, 12 STR - 12 STR SUC (RES TO VDP CASE)
3	731053	1	HOSE, 16 STR - 16 90 RET (COOLER UPPER TO RES)
4	731054	1	HOSE, 10 STR - 10 STR RET (VALVE T2 TO COOLER)
5	731055	1	HOSE, 10 STR - 8 90 RET (VDP CASE TO RES)
6	731056	1	HOSE, 8 STR - 10 90 MED (MB LEFT TO VALVE T2)
7	731057	1	HOSE, 8 STR - 10 STR MED (IMP SOL T TO COOLER)
8	731058	1	HOSE, 8 STR - 8 STR MED (AUX PUMP 2 TO IMP SOL P)
9	731059	1	HOSE, 8 STR - 8 STR MED (AUX PUMP 1 TO VALVE P2)
10	731060	1	HOSE, 8 STR - 8 90 MED (VALVE MB OUT TO MB RIGHT)
11	731061	1	HOSE, 8 STR - 8 90 MED (IMP SOL VF OUT TO IMP LEFT)
12	731062	1	HOSE, 8 STR - 8 90 MED (IMP RIGHT TO IMP SOL VF IN)
13	731063	1	HOSE, 6 STR - 6 45 MED (AUX PUMP 3 TO VALVE P1)
14	731064	1	HOSE, 6 STR - 6 90 MED (VALVE P1 TO STR PRESS)
15	731065	1	HOSE, 6 STR - 8 STR RET (STR TANK TO VDP CASE)
16	731066	1	HOSE, 6 STR - 6 STR MED (STR LEFT TO CYL F)
17	731067	1	HOSE, 6 STR - 6 STR MED (STR RIGHT TO CYL R)
18	731068	1	HOSE, 4 STR - 4 45 MED (VALVE BL A TO SH CYL F)
19	731069	1	HOSE, 4 STR - 4 45 MED (VALVE BL B TO SH CYL R)
20	731070	1	HOSE, 4 STR - 4 STR MED (VALVE SG B TO SQU CYL F)
21	731071	1	HOSE, 4 STR - 4 STR MED (VALVE SG A TO SQU CYL R)
22	731072	1	HOSE, 4 STR - 4 45 MED (MB CASE TO MB MOTOR)
23	731073	1	HOSE, 4 STR - 4 90 MED (MB CASE TO IMP CASE)
24	731074	1	HOSE, 4 STR - 4 90 MED (IMP CASE TO RES)
25	731075	1	HOSE, 4 STR - 4 90 MED (VALVE T1 TO RES)
26	731076	1	HOSE, 4 STR - 4 45 MED (WHEEL DRIVE CASE TO RES)
27	731077	1	HOSE, 8 STR - 8 45 SPCL (VDP L TO WHEEL DRIVE R)
28	731078	1	HOSE, 8 STR - 8 45 SPCL (VDP R TO WHEEL DRIVE F)

HOSE CLAMP GROUP (730149)

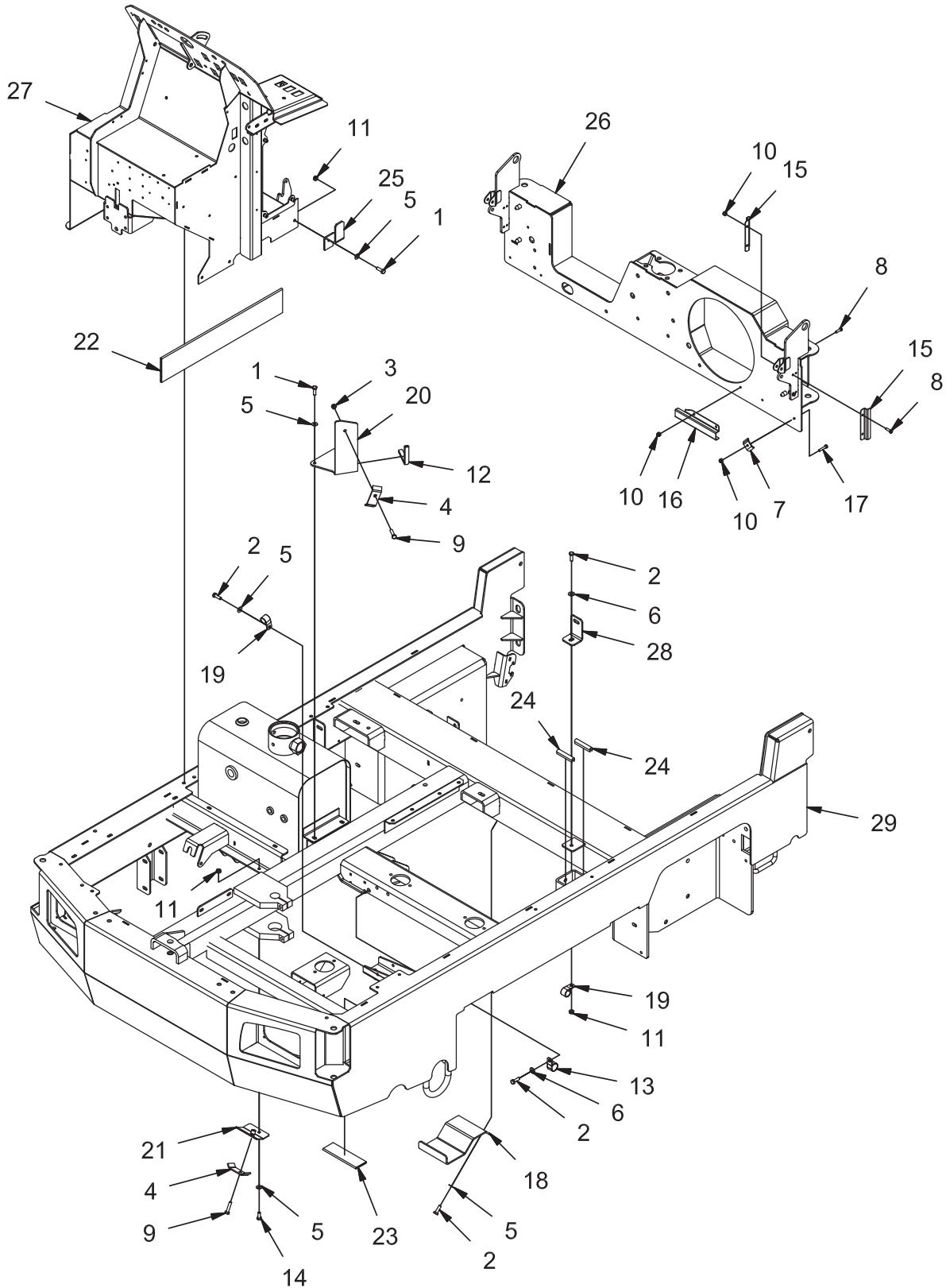

REV C

HOSE CLAMP GROUP (730149)

Parts List			
ITEM	PART NUMBER	QTY	DESCRIPTION
1	11038247	3	BLT-HH M8-1.25 X 25 STL ZINC
2	11039567	5	BOLT, M8-1.25 X 25 HH SS
3	12040259	1	NUT, M8-1.25 ESN SS
4	3305398	2	RETAINER, HOSE, OFFSET, 8
5	3400384	7	WASHER, 5/16 BELLEVILLE
6	3400385	2	WASHER, 3/8, BELLEVILLE
7	600822	1	RETAINER, HOSE, SYM, 6
8	600913	4	BOLT, M6-1.00 X 20 HH SS
9	600918	2	BOLT, M8-125 X 35 HH
10	600933	5	NUT, M6-1.00 ESN SS
11	600934	5	NUT, M8-1.25 FLNG
12	620039	1	EDGING, 3/16 X 5.75"
13	690011	1	CLAMP, P TYPE, 1.00 DIA
14	717030	1	BOLT, M8-1.25 X 20 HH SS
15	730880	2	HOSE RETAINER, SINGLE
16	730881	1	HOSE RETAINER, DOUBLE
17	731050	1	BOLT, M6-100 X 30 HH SS
18	731145	1	BRACKET, HOSE TRAY
19	731146	2	CLAMP, HOSE, .88
20	731147	1	TRAY, REAR HOSE
21	731148-1	1	ASSEMBLY, HOSE CLAMP BRACKET
22	731150	1	SLEEVE, AS-B-37 X 30.0"
23	731151	1	SLEEVE, AS-B-17 X 6.0"
24	731152	2	EDGING, .31 X 2.75"
25	731153	1	BRACKET, CENTER HOSE
26	REF.	-	BUMPER
27	REF.	-	CONSOLE
28	REF.	-	BRACKET, TANK MNT
29	REF.	-	FRAME

DECAL GROUP (730150)

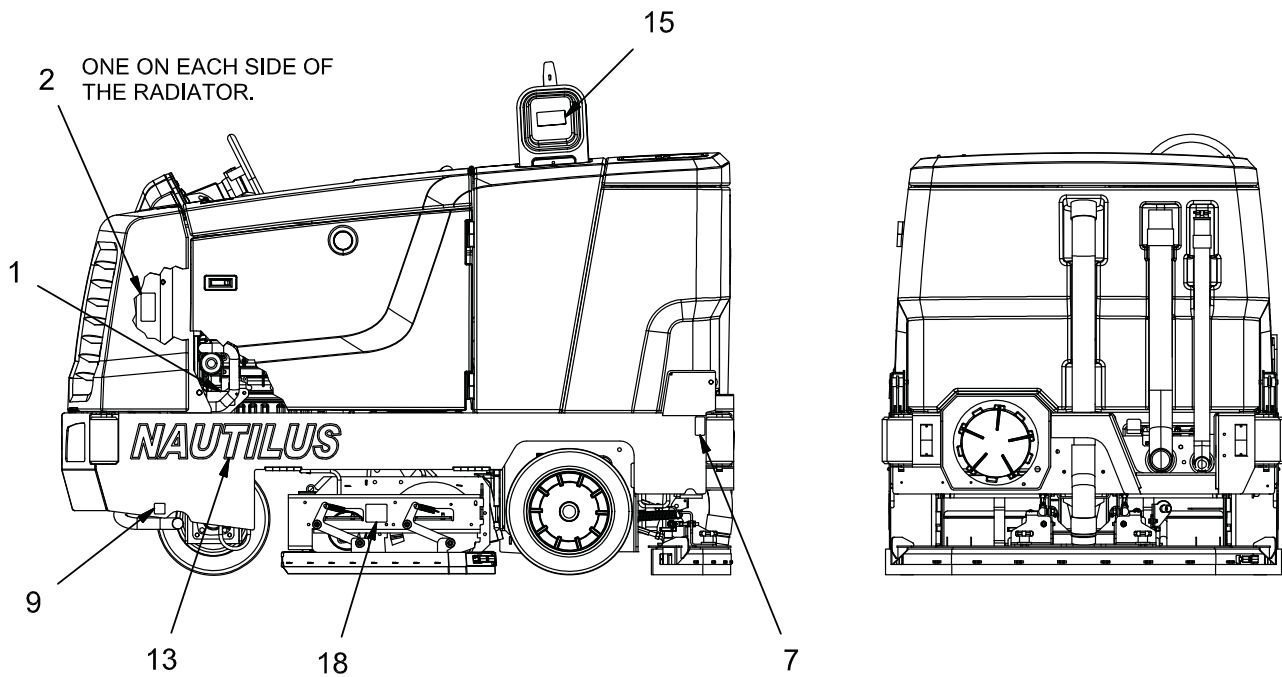
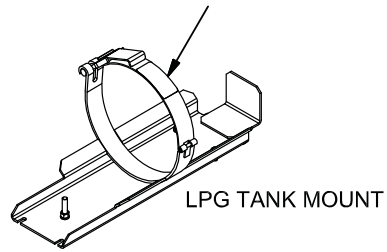
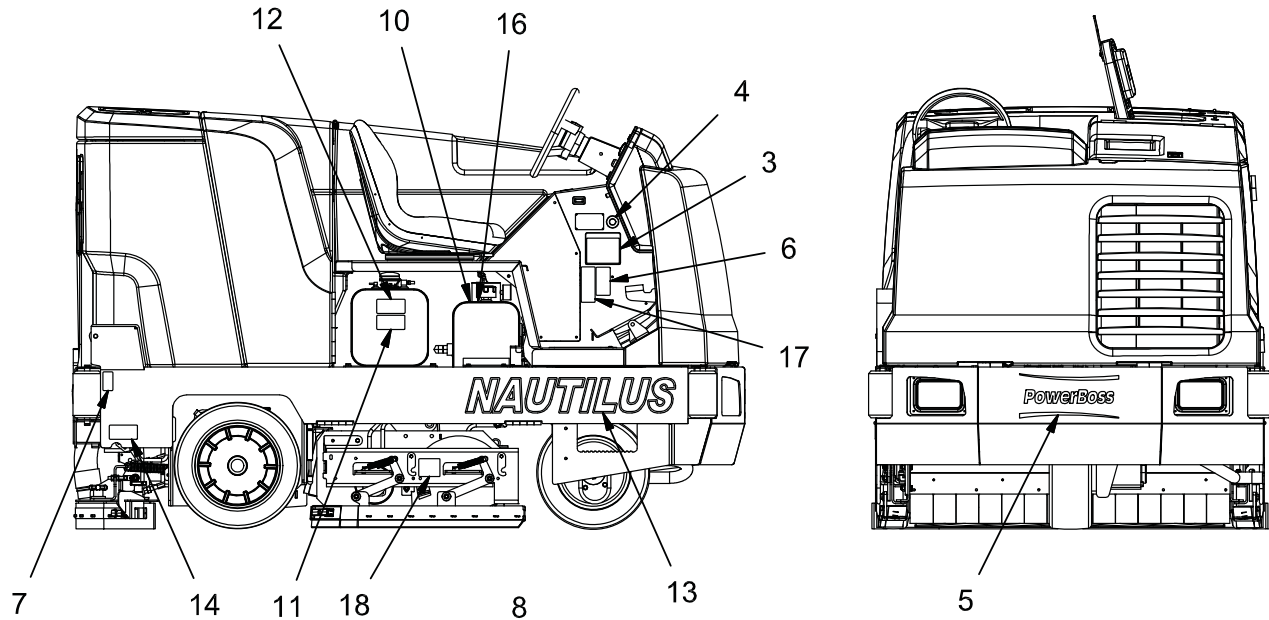

REV A

DECAL GROUP (730150)

Parts List DECAL GROUP 730150			
ITEM	PART NUMBER	QTY	DESCRIPTION
1	3301730	1	DECAL, WARNING FAN BELT (ENG)
2	3301733	2	DECAL, WARNING FAN (RAD SHROUD)
3	3301854	1	DECAL, CAUTION
4	3334827	1	DECAL, MADE IN USA
5	3334900	1	DECAL, POWERBOSS
6	3342264	1	DECAL, READ MANUAL
7	3342650	2	DECAL, PINCH POINT
8	3342971	1	DECAL, LPG FUEL TANK (LPG ONLY)
9	3342978	1	DECAL, HOT SURFACE
10	715023	1	DECAL, HYDRAULIC FLUID INFORMATION
11	715949	1	DECAL, GAS FUEL WARNING (GAS MACHINE ONLY)
12	715953	1	DECAL, DIESEL FUEL WARNING (DIESEL MACHINE ONLY)
13	715962	2	DECAL, NAUTILUS
14	715963	1	DECAL, BUMPER LATCH
15	715965	1	DECAL, FLAMMABLE MATERIAL WARNING
16	715966	1	DECAL, WARNING, NO FUEL IN RES.
17	715967	1	DECAL, WARNING, DO NOT PICK UP
18	715968	2	DECAL, WARNING, ROTATING BRUSHES

ELECTRICAL GROUP (730116)

NOTE:

THERE IS NO PICTURE AVAILABLE FOR THIS GROUP

REV C

ELECTRICAL GROUP (730116)

Parts List			
ITEM	PART NUMBER	QTY	DESCRIPTION
1	748990	1	ENGINE HARNESS
2	749035	1	LIGHTS HARNESS
3	748799	1	HARNESS, MAIN, NAUTILUS
4	731146	2	CLAMP, HOSE, .88
5	740482	1	DIODE ASY, 1N4007 W/PIGGY
6	746050	2	INSULATOR CAP, TERMINAL RED

BRUSH/BROOM GROUP (730175)

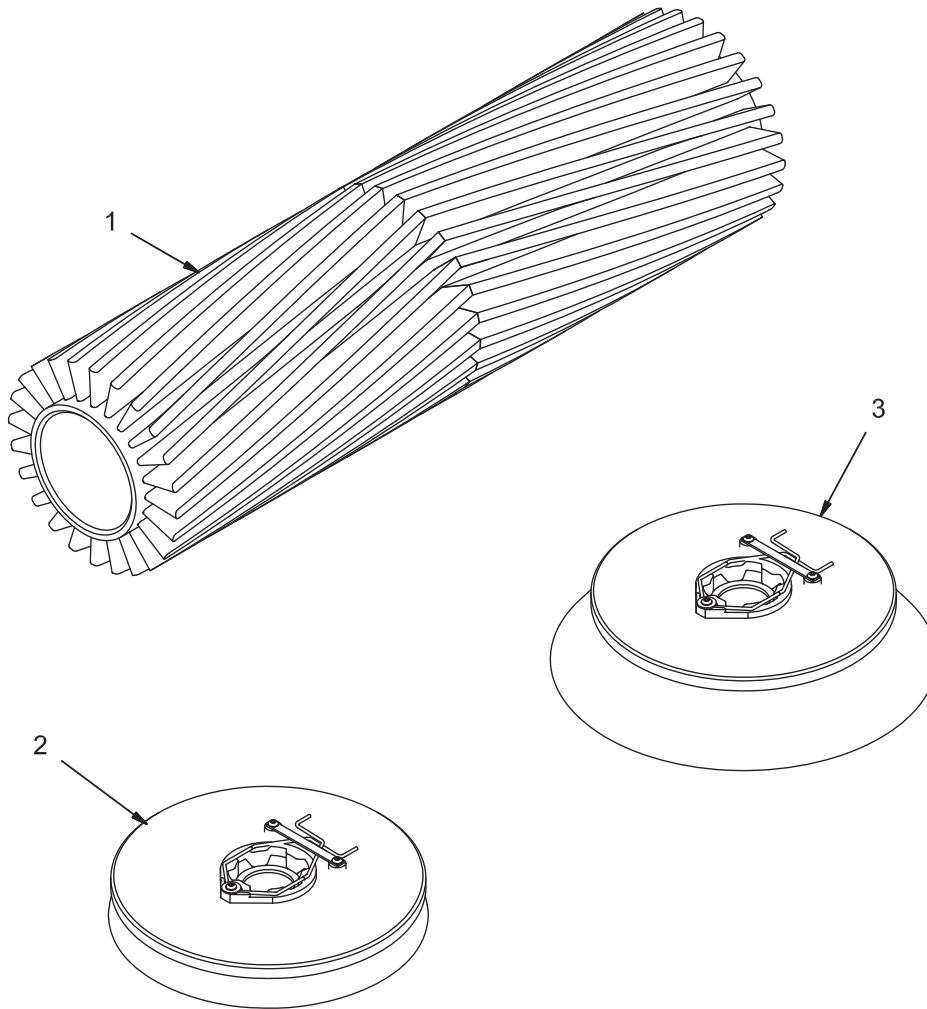

REV D

BRUSH/BROOM GROUP (730175)

Parts List - 730175			
ITEM	PART NUMBER	QTY	DESCRIPTION
1	731090	1	BRUSH, CYLINDRICAL, 45", NYLON
1	731295	1	BRUSH, CYLINDRICAL, 45", POLY
1	731296	1	BRUSH, CYLINDRICAL, 45", 80 GRIT ABRASIVE
1	731588	1	BRUSH, CYLINDRICAL, 45", 180 GRIT ABRASIVE
2	3313128	1	BRUSH, DISC, 16", PURPLE
2	3313126	1	BRUSH, DISC, 16", BLACK
2	3332545	1	BRUSH, DISC, 16", BLUE
2	3315385	1	BRUSH, DISC, 16", RED
2	3313136	1	BRUSH, DISC, 16", NYLON
3	731259	1	SIDE BROOM, 20", POLY

OPTIONS - PARTS BREAKDOWN

OPTION - SIDE BRUSH GROUP (730000)

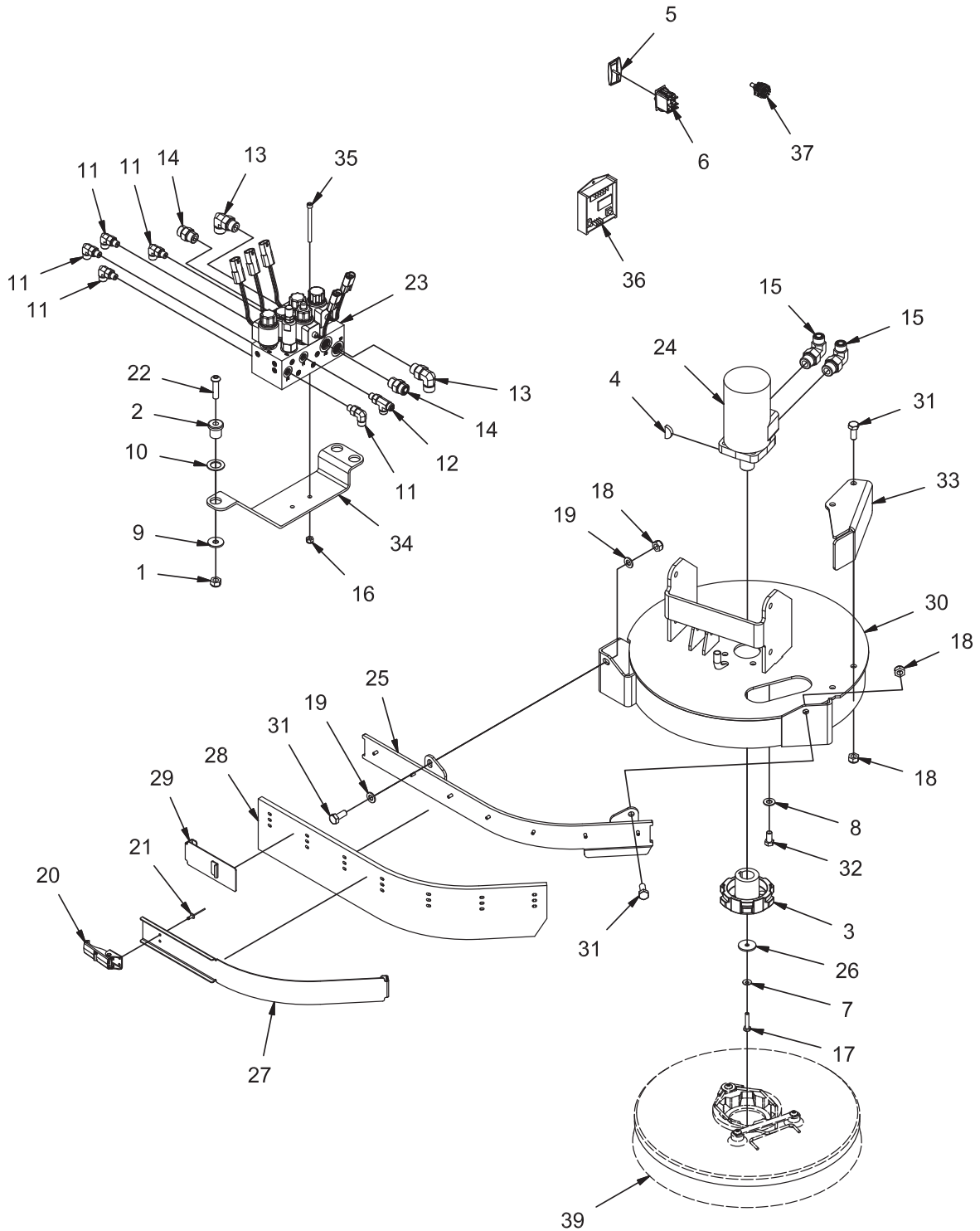

REV C

OPTION - SIDE BRUSH GROUP (730000)

Parts List 730000			
ITEM	PART NUMBER	QTY	DESCRIPTION
1	12040069	3	NUT, M10-1.50 ESN
2	3300465	3	ISOLATOR, VIB
3	3324451	1	HUB, DRIVE
4	3330338	1	KEY, WOODRUFF .25 X .50
5	3342273	1	SWITCH COVER - BLACK, CLEAR LENS
6	3342705	1	SWITCH, DPST
7	3400383	1	WASHER, 1/4 BELLEVILLE
8	3400385	4	WASHER, 3/8, BELLEVILLE
9	600363	3	WASHER, ISOLATOR
10	66-431-A	3	WASHER, .77 B 1.25 OD .075 T
11	675507	5	FITTING, 90, -4 ORFS - 4 SAE
12	675509	1	FITTING, RUN TEE -4 ORFS TO -4 SAE
13	675523	2	FITTING, 90, -8 ORFS - 8 SAE
14	675524	2	FITTING, STR, -8 ORFS - 8 SAE
15	675528	2	FITTING, 90, -8 ORFS - 10 SAE
16	711373	2	NUT, FIBER INSERT 1/4-20
17	712566	1	SCREW, 1/4-20 X 1.25 HH SS
18	730339	4	NUT, M10-1.50 ESN SS
19	730344	2	WASHER, M10 SS
20	730652	1	LATCH, UNDER CENTER
21	730654	2	RIVET,BLIND, .156 D X .062 - .125 GRIP SS
22	730698	3	BOLT, M10-1.50 X 40 BUTTON HD CAP
23	730795-1	1	MANIFOLD ASSY, SSB
24	730892	1	MOTOR, 9.7 DISP
25	730927	1	WELDMENT, SSB SQU MNT
26	730933	1	WASHER, .28 B, 1.25 OD, .105 T SS
27	730938	1	SSB SQU RETAINER
28	730939	1	SSB SQUEEGEE
29	730940	1	WELDMENT, SSB REAR RET
30	730942	1	WELDMENT, SSB MOUNT
31	730958	4	BOLT, M10-1.50 X 25 HH SS
32	730959	4	SCREW, 3/8-16 X .750 HHC SS
33	730963	1	WELDMENT, SSB GUARD
34	730964	1	MOUNT, SSB MANIFOLD
35	730965	2	BOLT, 1/4-20 X 3.00 SOC HD CAP
36	731126	1	PROPORTIONAL VALVE DRIVER - DOUBLE
37	748796	1	DUAL BRUSH PRESSURE SELECTOR
38	748798	1	HARNESS, SIDE BRUSH
39	REF.	-	SCRUB BRUSH, 16 D

**GROUP (730036) - OPTION SIDE SCRUB BRUSH, INCLUDES SUB-GROUPS:
730000, 730001, 730002, 730011, 730028, 730029**

OPTION - SIDE BRUSH LIFT GROUP (730001)

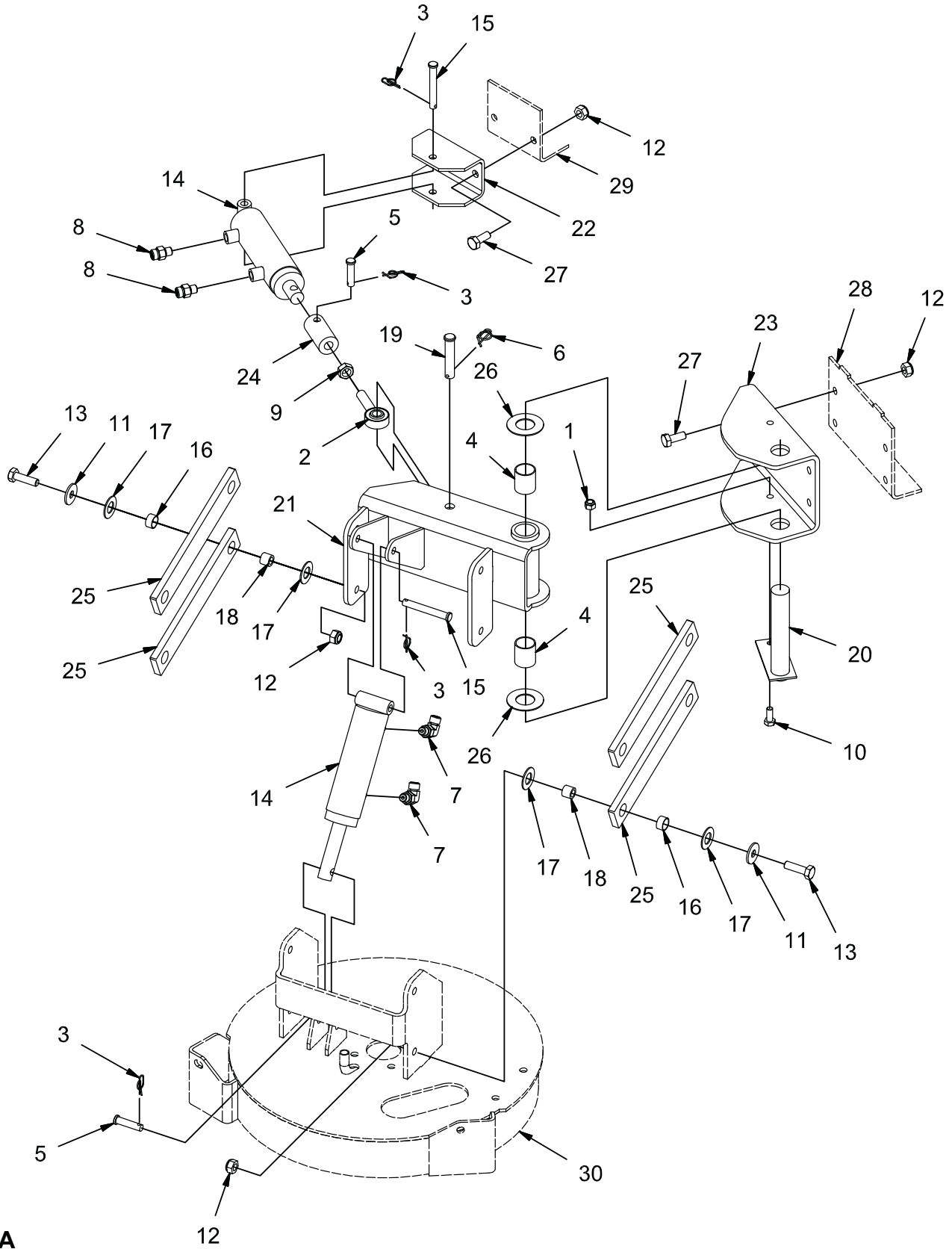

REV A

OPTION - SIDE BRUSH LIFT GROUP (730001)

Parts List 730001			
ITEM	PART NUMBER	QTY	DESCRIPTION
1	12040259	1	NUT, M8-1.25 ESN SS
2	3311977	1	ROD END, MALE, 1/2-20
3	3400125	4	RUE-RING, .375
4	600174	2	BEARING, FIBERGLIDE 1.00 ID 1.25 T
5	600573	2	PIN, CLEVIS, 3/8 X 1.50
6	600578	1	RUE-RING, .50
7	675507	2	FITTING, 90, -4 ORFS - 4 SAE
8	675508	2	FITTING, STR, 4 ORFS - 4-SAE
9	711337	1	NUT, HEX JAM 1/2-20
10	717030	1	BOLT, M8-1.25 X 20 HH SS
11	717040	8	WASHER, FENDER, .413 B 1.18 OD .098 T SS
12	730339	14	NUT, M10-1.50 ESN SS
13	730345	8	BOLT, M10-1.50 X 35 HH SS
14	730548	2	CYLINDER, HYD, 1.50 B X 2.88 STK
15	730602	2	PIN, CLEVIS, .375 X 2.75
16	730646	8	BEARING, DU, .63 B .72 OD .38 T
17	730647	16	WASHER, THRUST, .66 B 1.25 OD .06 T
18	730648	8	SPACER, .406 B .624 OD .515 T SS
19	730875	1	PIN, CLEVIS 1/2 X 2.50 ZP
20	730907	1	WELDMENT, PIN
21	730910	1	WELDMENT, SSB ARM
22	730923	1	SSB CYL MNT
23	730924	1	SSB MNT
24	730925	1	SSB ADJ TUBE
25	730926-1	4	SSB LINK
26	730957	2	WASHER, THRUST, 1.03 B 2.00 OD .063 T
27	730958	6	BOLT, M10-1.50 X 25 HH SS
28	REF.	-	FRAME
29	REF.	-	FRAME
30	REF.	-	SSB MOUNT

**GROUP (730036) - OPTION SIDE SCRUB BRUSH, INCLUDES SUB-GROUPS:
730000, 730001, 730002, 730011, 730028, 730029**

OPTION - SIDE BRUSH SOLUTION CONTROL GROUP (730002)

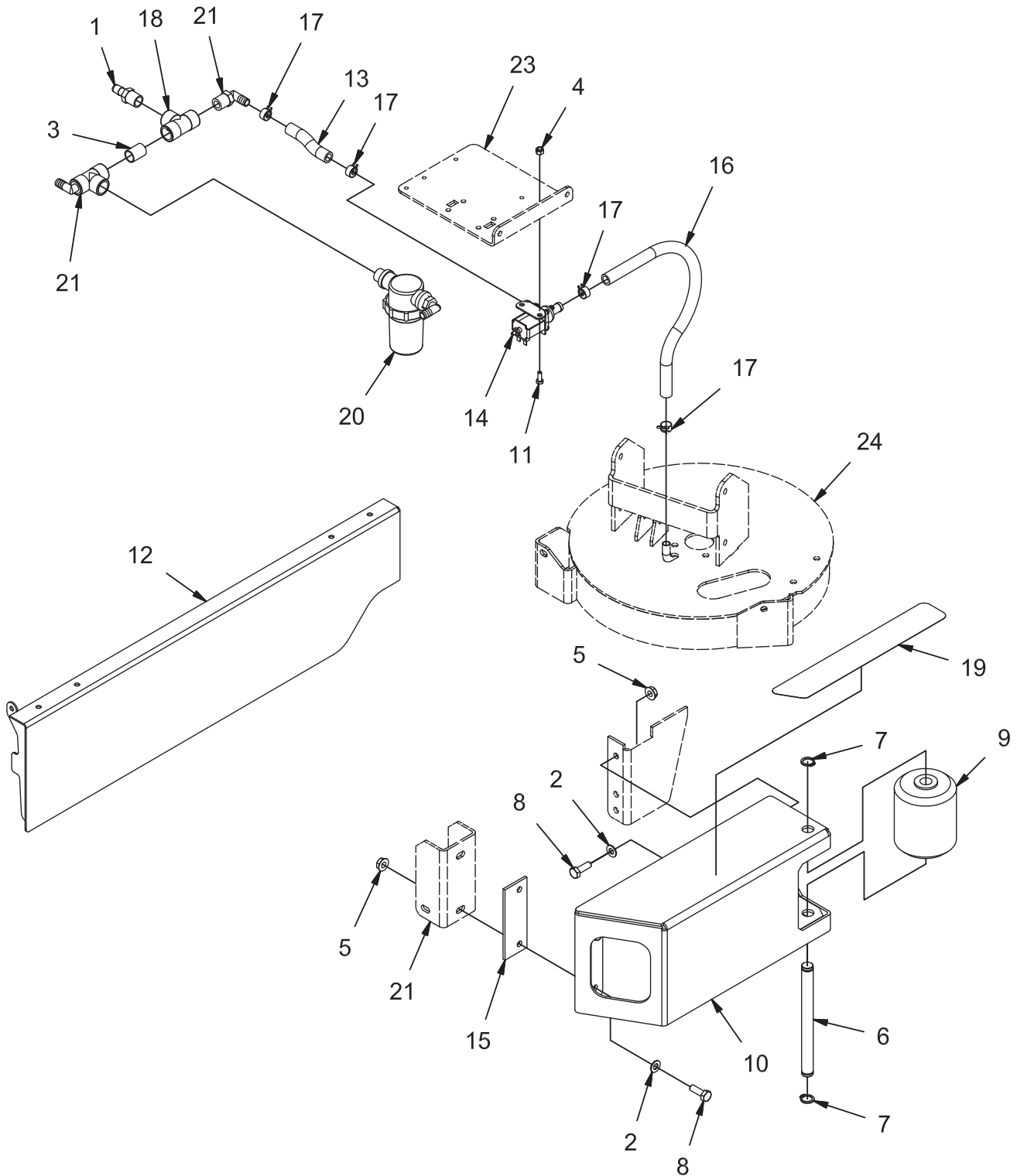

REV A

OPTION - SIDE BRUSH SOLUTION CONTROL GROUP (730002)

Parts List 730002			
ITEM	PART NUMBER	QTY	DESCRIPTION
1	3315534	1	FITTING, PLASTIC, STR, .50 NPT .50 BARB
2	3400385	4	WASHER, 3/8, BELLEVILLE
3	383465	1	1/2 NPT CLOSE PIPE NIPPLE, BRASS
4	600933	2	NUT, M6-1.00 ESN SS
5	600936	4	NUT, M10-1.50 FLNG
6	730876	1	PIN, ROLLER
7	730877	2	RETAINING RING, EXT, .750
8	730878	4	BOLT, M10-1.50 X 30 HH SS
9	730915	1	ROLLER, SSB
10	730916	1	WELDMENT, SSB GUARD
11	730934	2	BOLT, M6-1.00 X 16 HH SS
12	730952	1	WELDMENT, SSB DOOR
13	730954	1	TUBING, .50 ID X .13 WALL BRAIDED VINYL
14	730956	1	VALVE, SOLENOID, 12V, ADJ
15	730960	1	SPACER PLT
16	730961	1	TUBING, .50 ID X .13 WALL BRAIDED VINYL
17	730962	4	CLAMP, WIRE HOSE
18	730966	1	FITTING, PVC TEE, FEMALE 1/2 NPT
19	730967	1	PAD, STEP
20	REF.	-	FILTER AND STD FITTING COMPONENTS
21	REF.	-	FRAME
22	REF.	-	FRAME
23	REF.	-	BRACKET, FILTER MNT
24	REF.	-	SSB MOUNT

**GROUP (730036) - OPTION SIDE SCRUB BRUSH, INCLUDES SUB-GROUPS:
730000, 730001, 730002, 730011, 730028, 730029**

OPTION - SIDE BRUSH HYDRAULIC HOSE GROUP (730011)

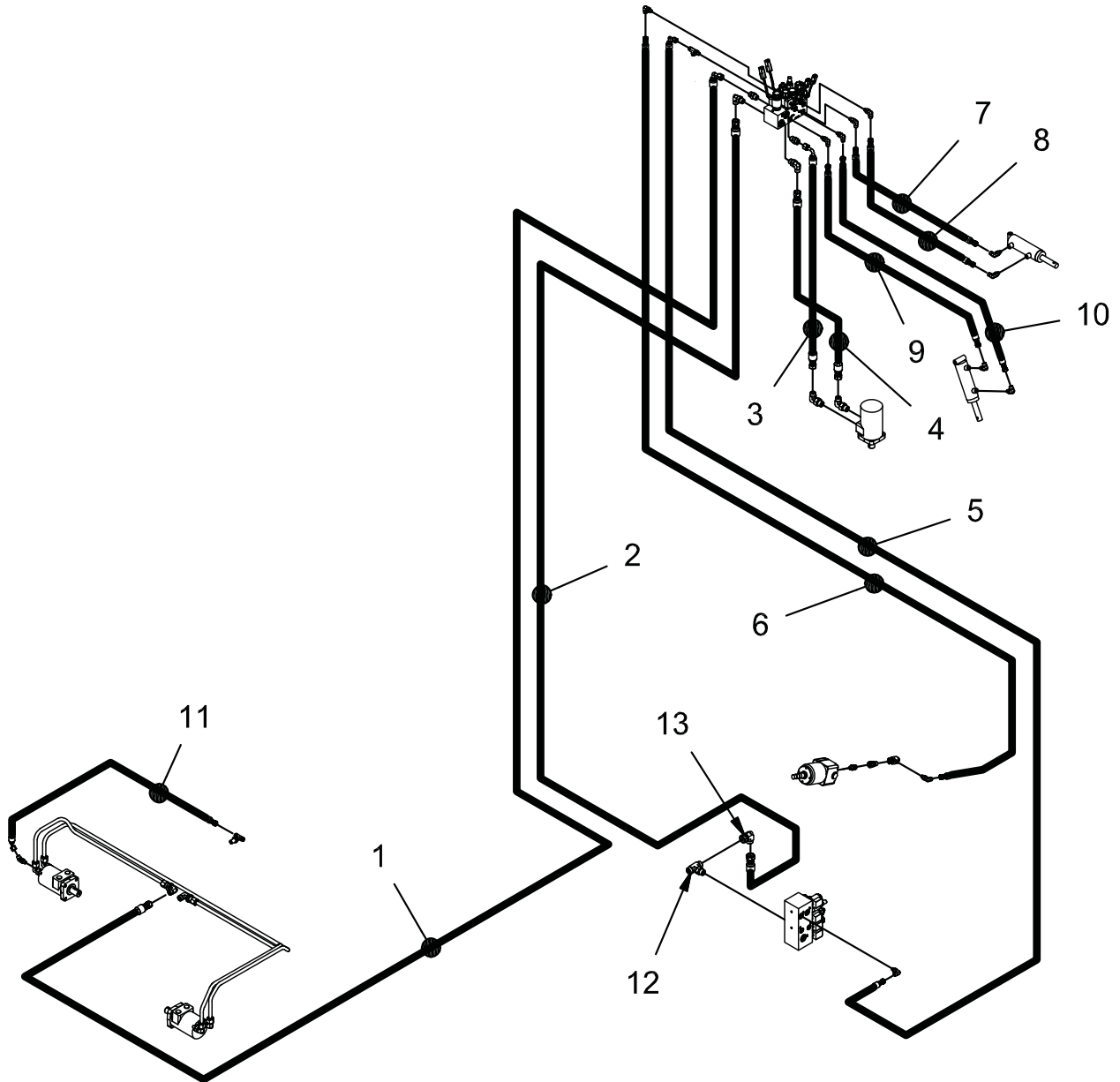

REV D

OPTION - SIDE BRUSH HYDRAULIC HOSE GROUP (730011)

Parts List 730011			
ITEM	PART NUMBER	QTY	DESCRIPTION
1	731079	1	HOSE, 8 STR - 8 90 MED (LH MB TO SSB VALVE P2)
2	731081	1	HOSE, 10 STR - 8 45 MED (VALVE T2 TO SSB VALVE T2)
3	731082	1	HOSE, 8 STR - 8 90 MED (SSB VALVE SB OUT TO SB R)
4	731083	1	HOSE, 8-STR - 8 STR MED (SSB VALVE SB IN TO SB F)
5	731084	1	HOSE, 4-STR - 4 STR MED (STR TEE TO SSB VALVE P1)
6	731085	1	HOSE, 4 STR - 4 90 MED (VALVE T1 TO SSB VALVE T1)
7	731087	1	HOSE, 4 STR - 4 STR MED (SSB VALVE SBE B TO EXT CYL R)
8	731088	1	HOSE, 4 STR - 4 STR MED (SSB VALVE SBL A TO LIFT CYL U)
9	731089	1	HOSE, 4 STR - 4 STR MED (SSB VALVE SBE A TO EXT CYL L)
10	731089	1	HOSE, 4 STR - 4 STR MED (SSB VALVE SBL B TO LIFT CYL L)
11	731168	1	HOSE, 4 STR - 4 45 MED (LH MB CASE TO SCRUB HEAD TEE)
12	675623	1	FTG - BRANCH TEE -10 ORFS TO -10 ORFS TO -10 SAE
13	675624	1	FTG - SWIVEL NUT ELBOW -10 ORFS TO -10 ORFS

**GROUP (730036) - OPTION SIDE SCRUB BRUSH, INCLUDES SUB-GROUPS:
730000, 730001, 730002, 730011, 730028, 730029**

OPTION - SIDE BRUSH SCRUB HEAD GROUP (730028)

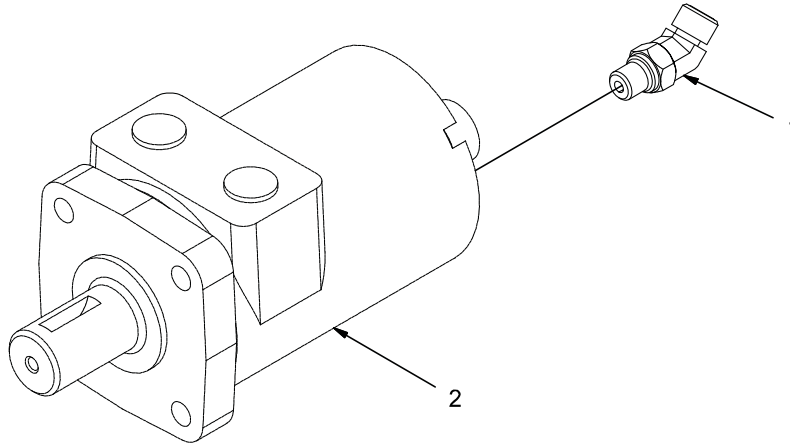

Parts List 730112			
ITEM	PART NUMBER	QTY	DESCRIPTION
1	675541	1	FITTING, 45, 4 ORFS - 4 SAE
2	REF.	-	LEFT SCRUB BRUSH MOTOR, 4.5 DISP

**GROUP (730036) - OPTION SIDE SCRUB BRUSH, INCLUDES SUB-GROUPS:
730000, 730001, 730002, 730011, 730028, 730029**

REV *

OPTION - SIDE BRUSH STEERING COLUMN GROUP (730029)

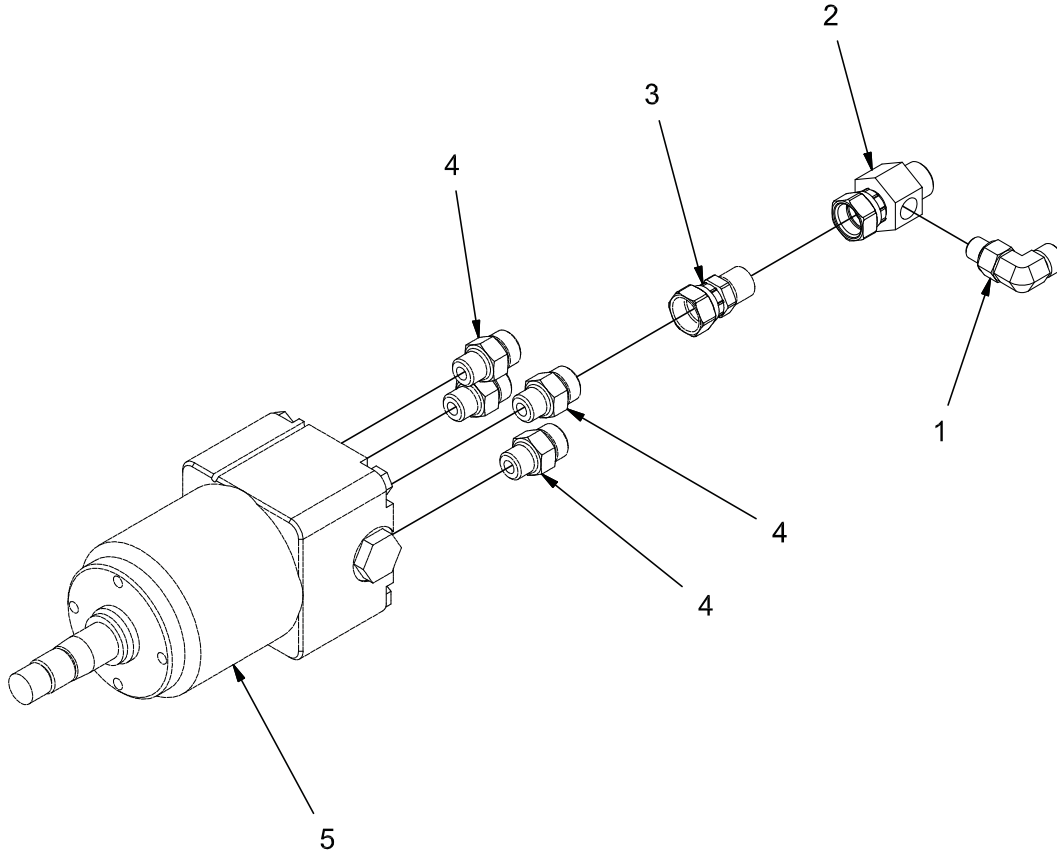

Parts List			
ITEM	PART NUMBER	QTY	DESCRIPTION
1	675507	1	FITTING, 90, -4 ORFS - 4 SAE
2	675604	1	FTG-TEE -6 ORFS TO -6 ORFS TO -4 SAE
3	REF.	-	FTG - .094 ORIFICE ADAPTER -6 ORFS TO -6 ORFS
4	REF.	-	FITTING, STR, 6 ORFS - 6 SAE
5	REF.	-	STEERING UNIT

**GROUP (730036) - OPTION SIDE SCRUB BRUSH, INCLUDES SUB-GROUPS:
730000, 730001, 730002, 730011, 730028, 730029**

REV *

OPTION - SSB HYDRAULIC MANIFOLD GROUP (730171)

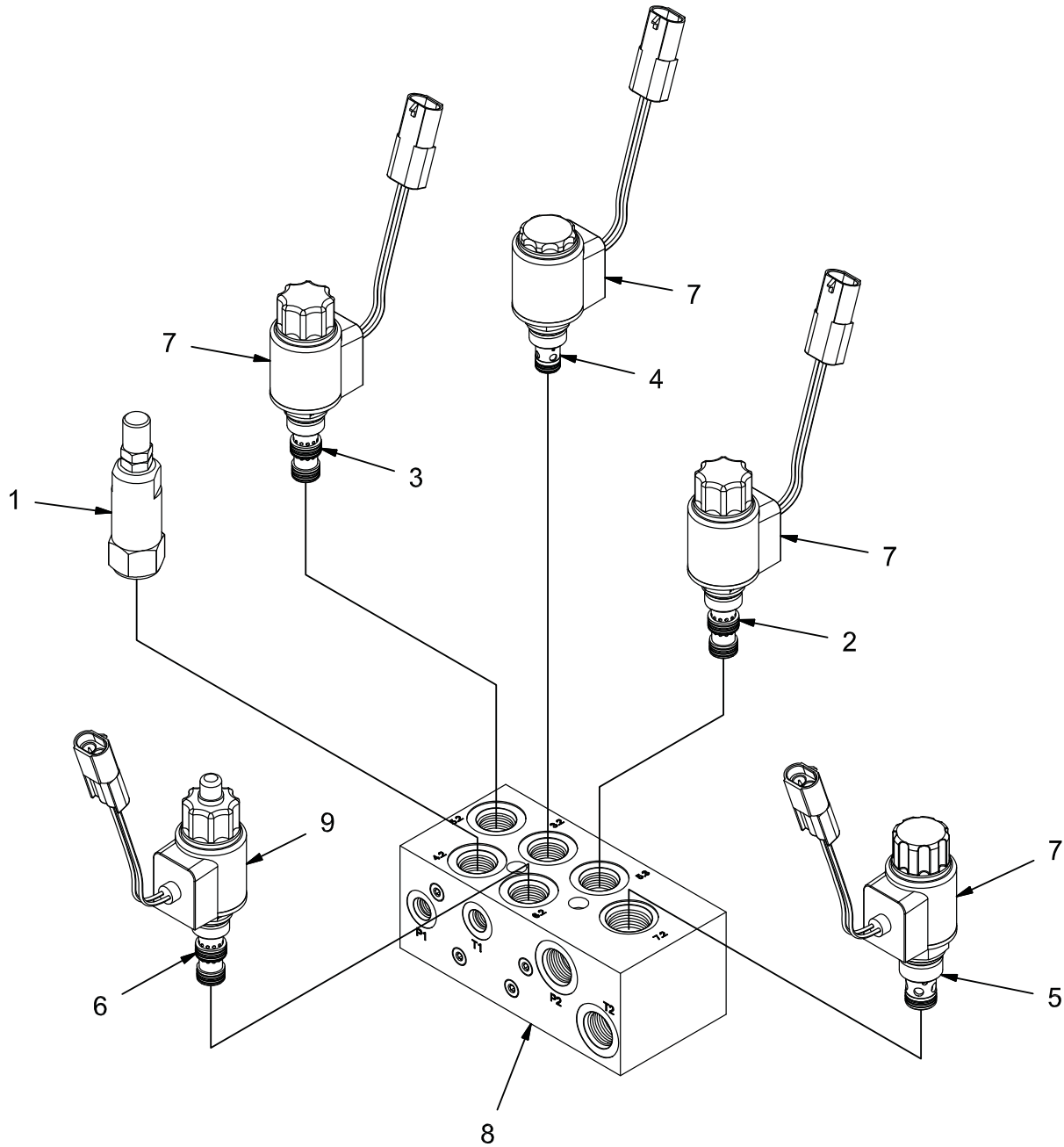

REV C

OPTION - SSB HYDRAULIC MANIFOLD GROUP (730171)

Parts List 730171			
ITEM	PART NUMBER	QTY	DESCRIPTION
1	730702	1	PORT 4.2 - RV4 - PRESSURE REDUCTION VALVE SOL. RED. VALVE, DR08-01-C-N-050-V-45
2	730705	1	PORT 5.3 - SV10 - SIDE BRUSH DOWN SOL. VALVE, WK08L-01-C-N-0
3	730705	1	PORT 5.2 - SV12 - SIDE BRUSH EXTEND SOL. VALVE, WK08L-01-C-N-0
4	730707	1	PORT 3.2 - SV11 - SIDE BRUSH UP - LOCK SOL. VALVE, WS08ZR-01-C-N-0
5	730709	1	PORT 7.2 - SV8 - SIDE BRUSH ON SOL. VALVE, WS10Y-01-C-N-0
6	730710	1	PORT 6.2 - SV9 - SIDE BRUSH FORCE PROP. RED. VALVE, PDR08-01-M-C-N-070
7	731122	4	COIL, 12V, 3003124
8	730700-1	1	MANIFOLD BLOCK, SSB
9	731226	1	COIL, PROPORTIONAL, 12PL-2.2-40-1836

OPTION - OVERHEAD GUARD GROUP (730003)

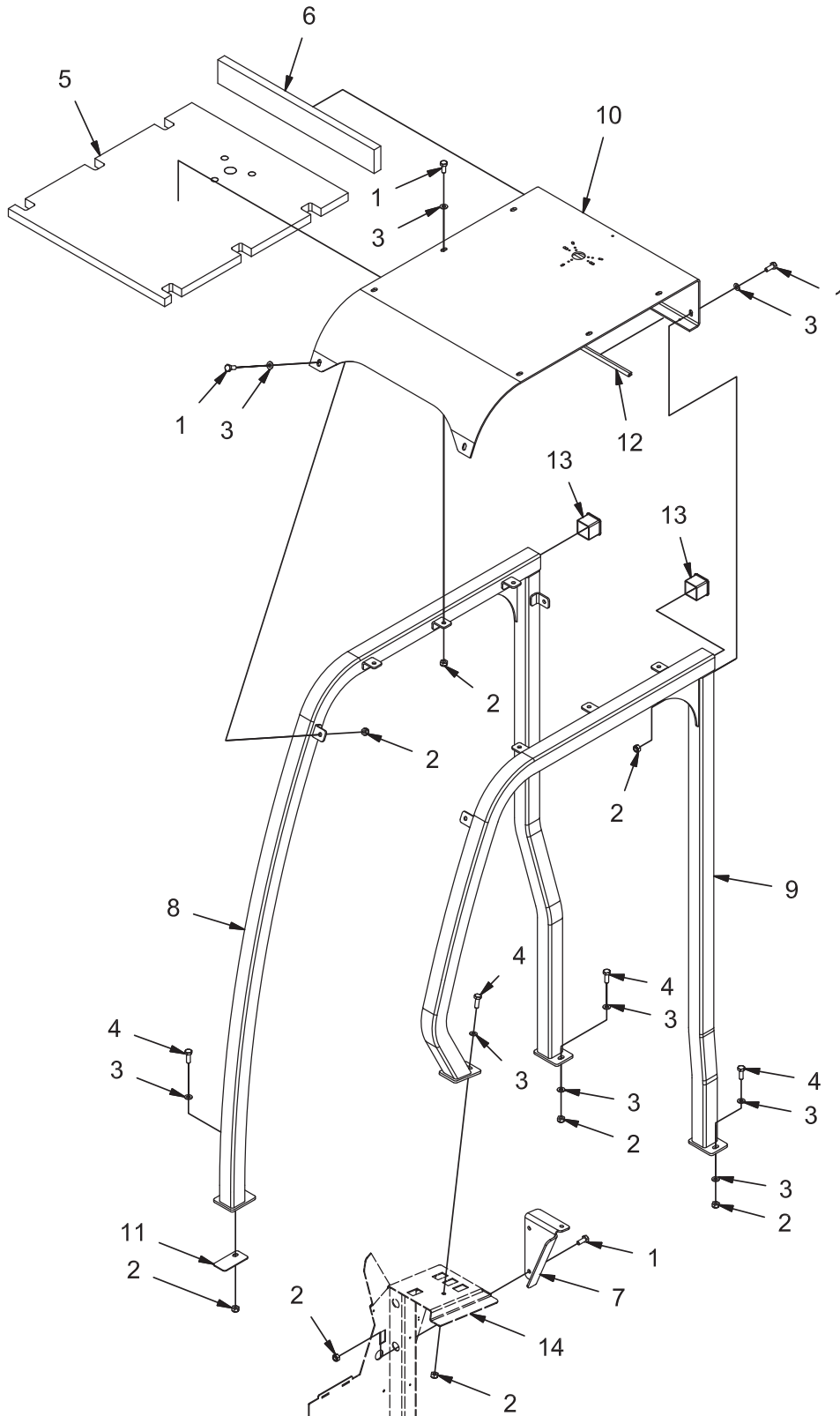

REV B

OPTION - OVERHEAD GUARD GROUP (730003)

Parts List - 730003			
ITEM	PART NUMBER	QTY	DESCRIPTION
1	11038346	12	BOLT, M10-1.50 X 25 HH
2	12040069	16	NUT, M10-1.50 ESN
3	12310058	16	WASHER, M10
4	3401051	4	BOLT, M10-1.50 X 30 HH
5	730388	1	INSULATION, SOUND, OHG TOP
6	730389	1	INSULATION, SOUND, OHG BACK
7	730697	1	BRACKET, OHG
8	731012	1	WELDMENT, OHG, RH SIDE
9	731020	1	WELDMENT, OHG, LH SIDE
10	731024	1	OHG, TOP PLT
11	731026	1	PLATE, SPACER
12	731027	1	EDGING, 3/16 X 23.62"
13	731028	2	PLUG, TUBING
14	REF.	-	CONSOLE

OPTION - LIGHT GROUP (ON OVERHEAD GUARD) (730189)

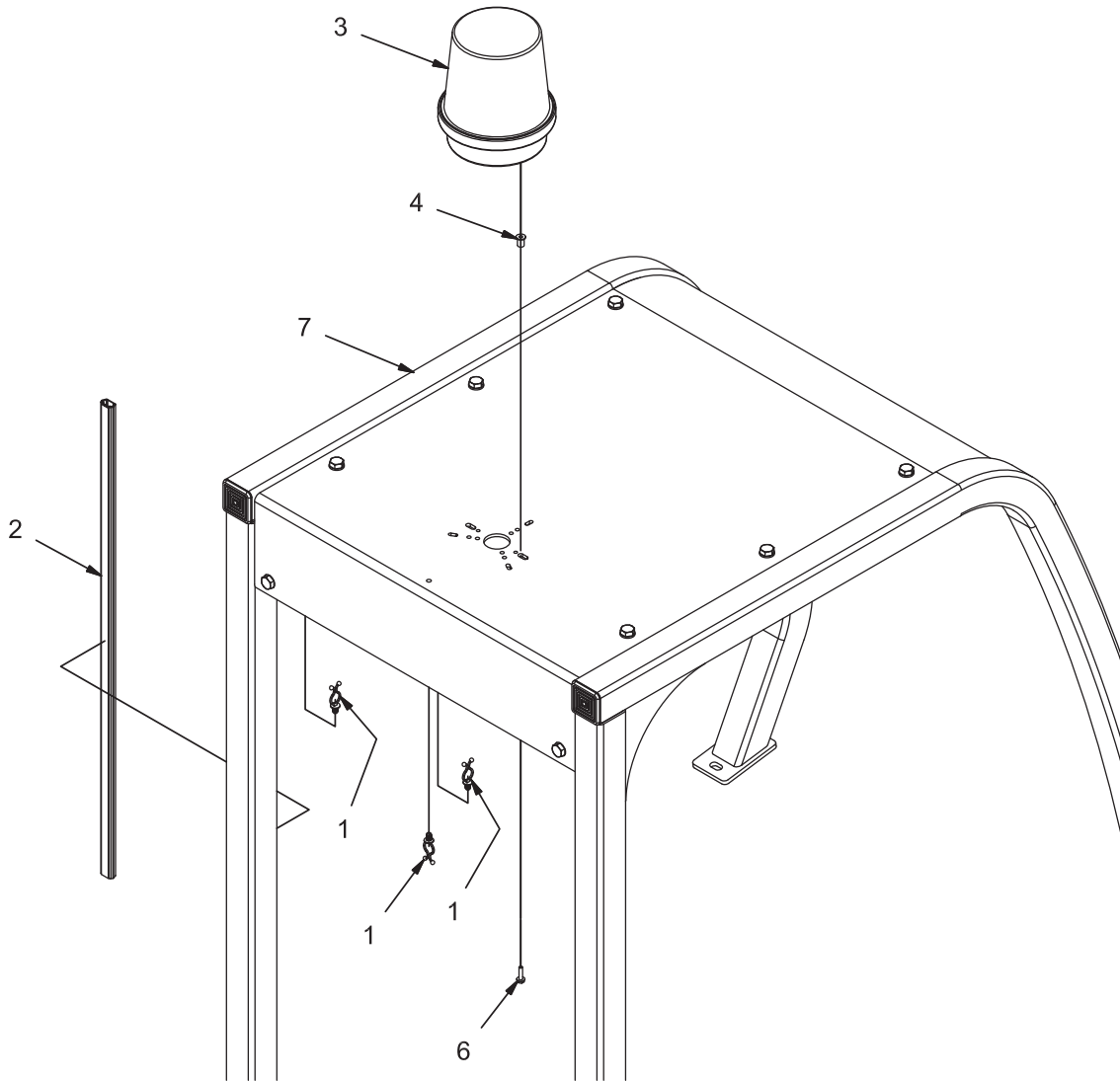

REV A

OPTION - LIGHT GROUP (ON OVERHEAD GUARD) (730189)

Parts List - 730189			
ITEM	PART NUMBER	QTY	DESCRIPTION
1	600581	3	CLAMP, WIRE CLIP
2	731029	1	WIRE CHANNEL
3	620073-1	1	ASSEMBLY, AMBER LED LIGHT
4	3400172	3	NUT-JAM 10-32 ZP NYLOC
6	3400044	3	SCREW
7	REF.	-	OVERHEAD GUARD
	748459	1	HARNESS, SAFETY LIGHT, OHG

OPTION - SUSPENSION SEAT GROUP (730007)

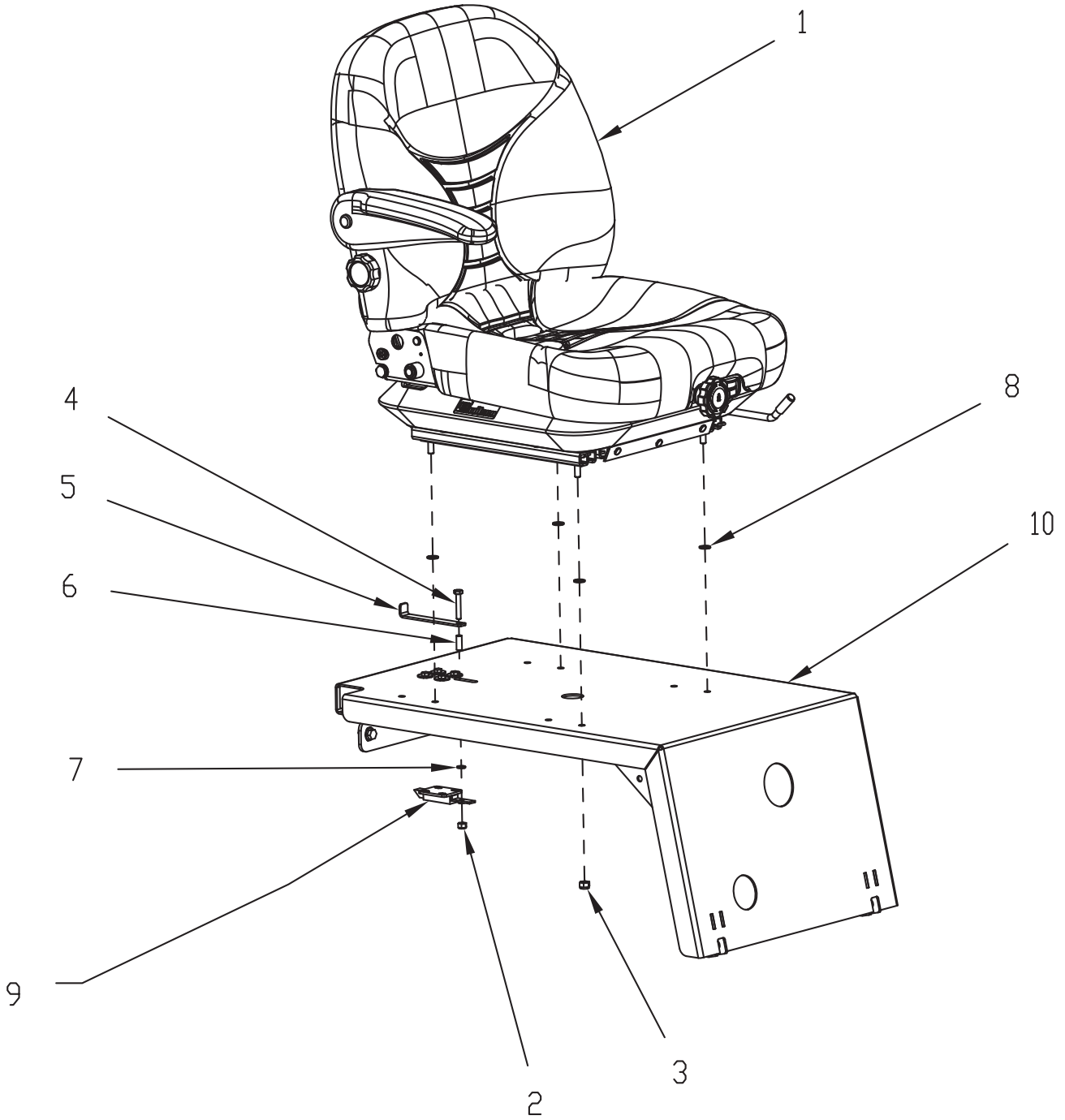

REV B

OPTION - SUSPENSION SEAT GROUP (730007)

Parts List - 730007			
ITEM	PART NUMBER	QTY	DESCRIPTION
1	620191	1	SEAT, SUSPENSION
2	711373	1	NUT, HEX 1/4-20 ZINC PL
3	711374	4	NUT, FIBER INSERT 5/16-18
4	713005	1	SCR-HH 1/4-20 X 1.50 ZP GR 5
5	731262	1	RELEASE, LATCH
6	731263	1	SPACER, .266 B, .313 OD, .813 T
7	12310033	1	WASHER-FLAT M6.4 X 12 X 1.6 ZP
8	12310041	4	WASHER, M8
9	REF.		SLIDE LATCH
10	REF.	-	SEAT MOUNT

OPTION - BACKUP ALARM GROUP (730008)
STANDARD ON CE AND UK MODELS

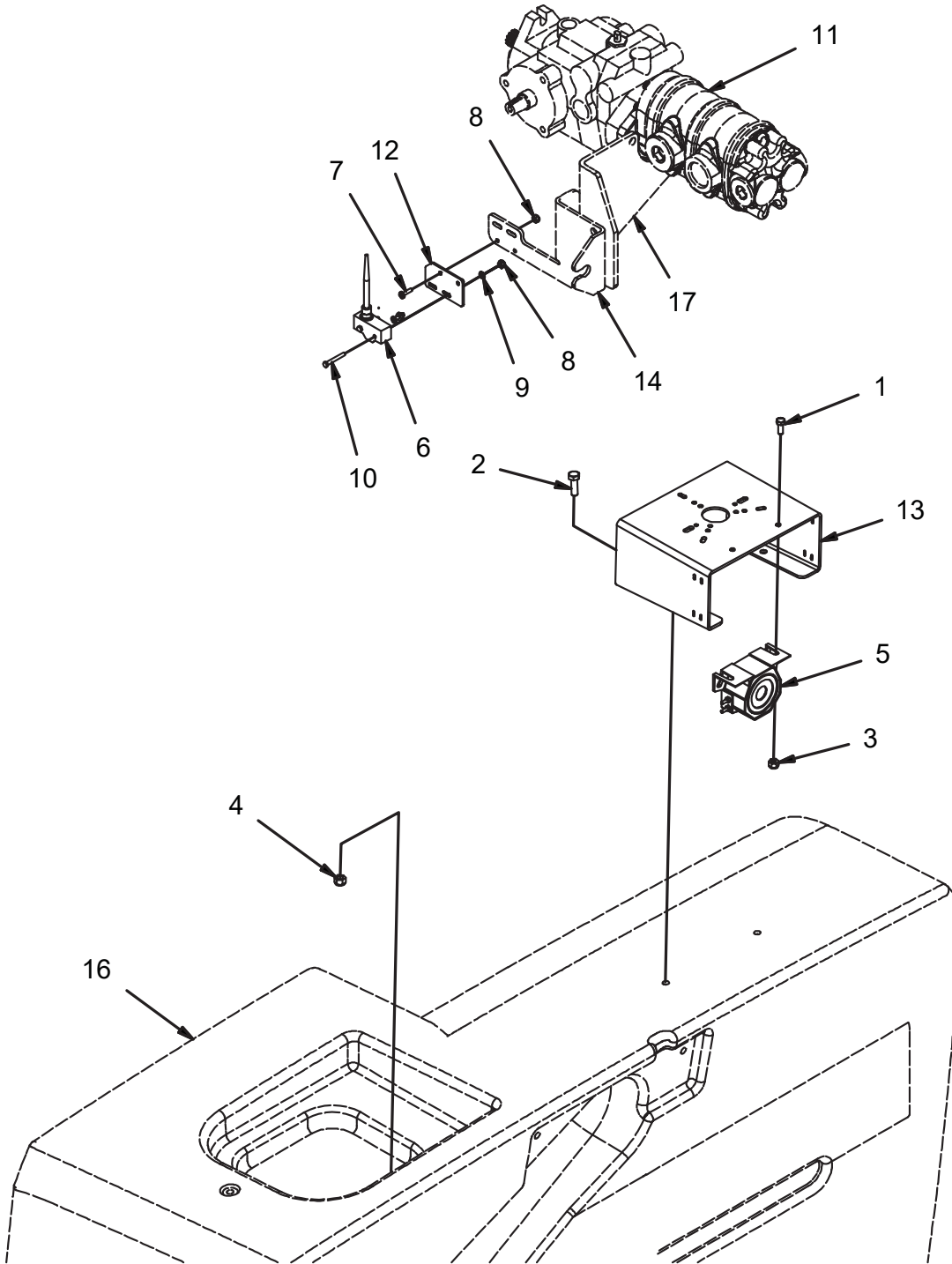

REV C

OPTION - BACKUP ALARM GROUP (730008)

Parts List 730008			
ITEM	PART NUMBER	QTY	DESCRIPTION
1	11038072	2	BOLT, M6-1.00 X 16 HH
2	11039567	2	BOLT, M8-1.25 X 25 HH SS
3	12040044	2	NUT, M6-1.00 ESN
4	12040259	2	NUT, M8-1.25 ESN SS
5	3303002	1	ALARM, BACKUP
6	3342546-1	1	HARNESS, SWITCH, WHISKER
7	3400045	2	SCREW, #8-32 X .625 PAN HD ZP
8	3400082	4	NUT, FIBER INSERT #8-32
9	3400096	2	FLATWASHER, #8
10	620136	2	BOLT, #8-32 X 1.25 HH ZP
11	REF.	1	PUMP, AUX
12	731002	1	MOUNT, REVERSE SWITCH
13	731030	1	MOUNT, SAFETY LIGHTS
14	REF.	-	ADJUSTER, HYDROBACK W/SW MNT
15	REF.	-	PUMP ASSEMBLY
16	REF.	-	SOLUTION TANK
17	REF.	-	HYDROBACK MOUNT
	748980	1	HARNESS, SAFETY LT & BACKUP ALARM
	748719	1	HARNESS ASSEMBLY, BACK UP ALARM

OPTION - SEAT BELT (FOR SUSPENSION SEAT) GROUP (730009)

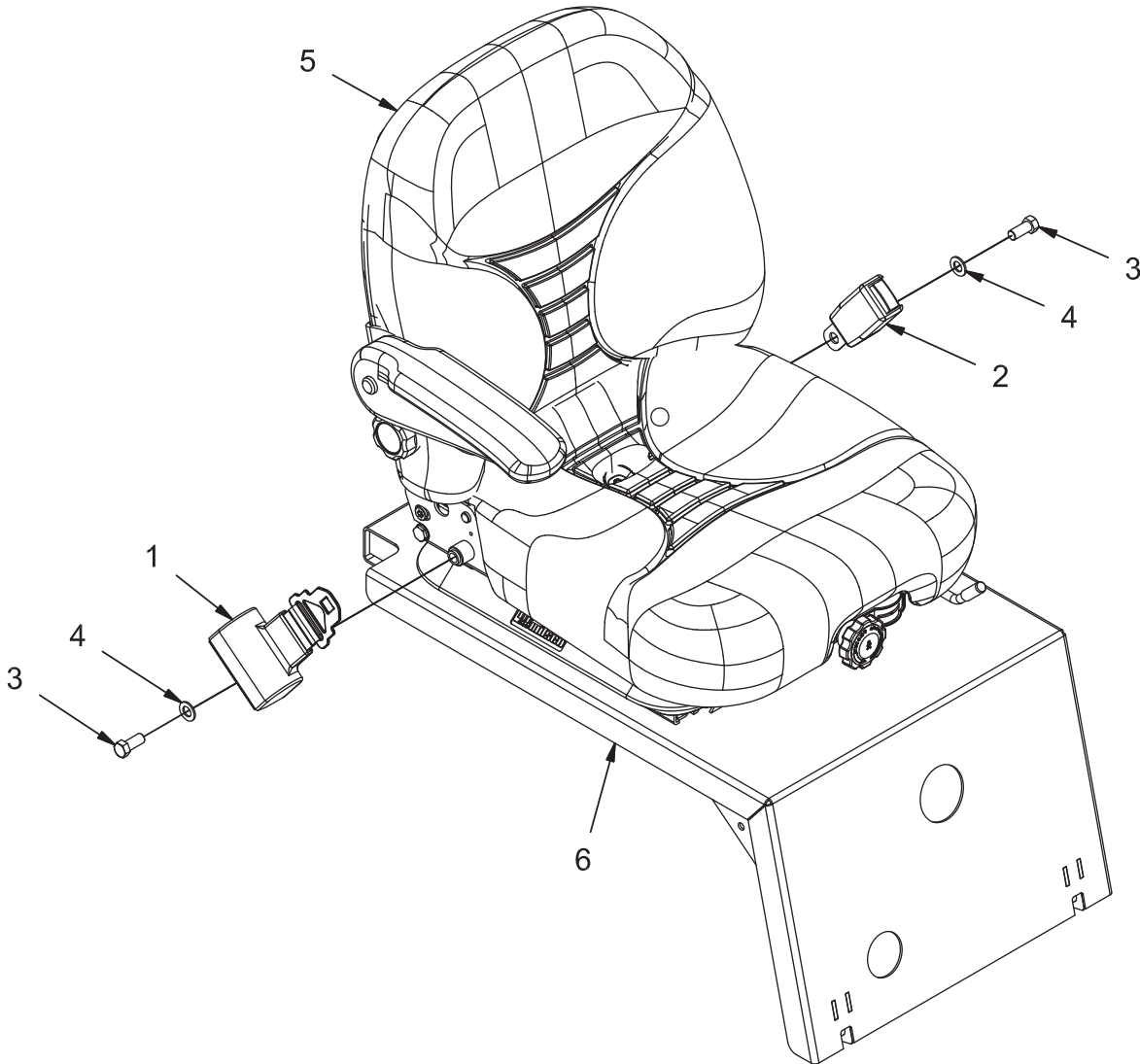

REV A

OPTION - SEAT BELT (FOR SUSPENSION SEAT) GROUP (730009)

Parts List - 730009			
ITEM	PART NUMBER	QTY	DESCRIPTION
1	PART OF 620192	1	SEAT BELT RETRACTOR
2	PART OF 620192	1	SEAT BELT RECEIVER
3	PART OF 620192	2	BOLT, 7/16-20 x 1.00
4	PART OF 620192	2	7/16 FLAT WASHER
-	620192	1	KIT, SEAT BELT
5	REF.	-	SEAT, SUSPENSION
6	REF.	-	SEAT MOUNT

OPTION - SEAT BELT (FOR STANDARD SEAT) GROUP (730010)

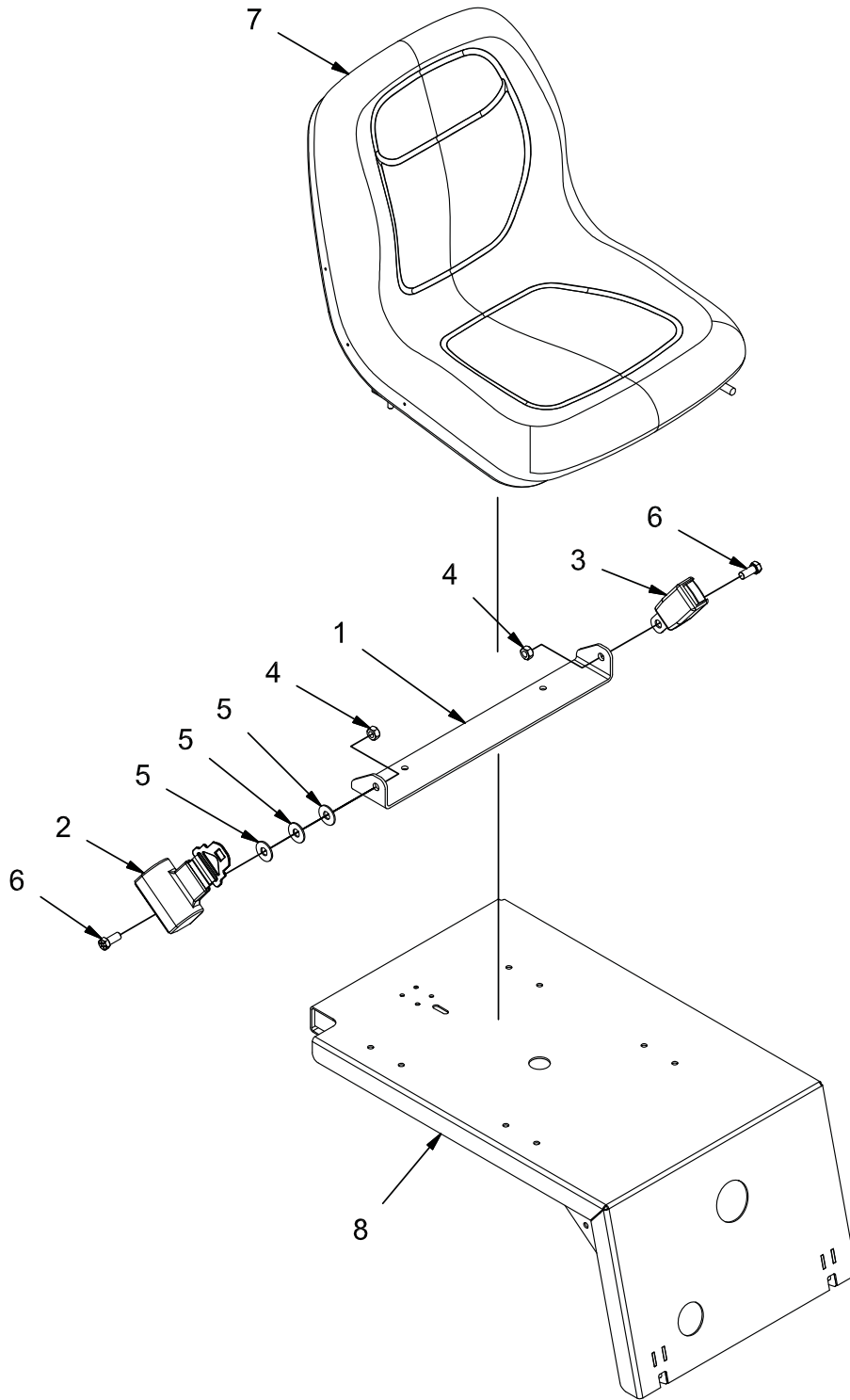

REV *

OPTION - SEAT BELT (FOR STANDARD SEAT) GROUP (730010)

Parts List - 730010			
ITEM	PART NUMBER	QTY	DESCRIPTION
1	620222	1	BRACKET, SEAT BELT
2	PART OF 620192	1	SEAT BELT RETRACTOR
3	PART OF 620192	1	SEAT BELT RECEIVER
4	PART OF 620192	2	NUT, 7/16-20
5	PART OF 620192	3	WASHER
6	PART OF 620192	2	BOLT, 7/16-20
-	620192	1	KIT, SEAT BELT
7	REF.	-	SEAT
8	REF.	-	WELDMENT, SEAT MNT

OPTION - LIGHT GROUP (ON SOLUTION TANK) (730189-4)

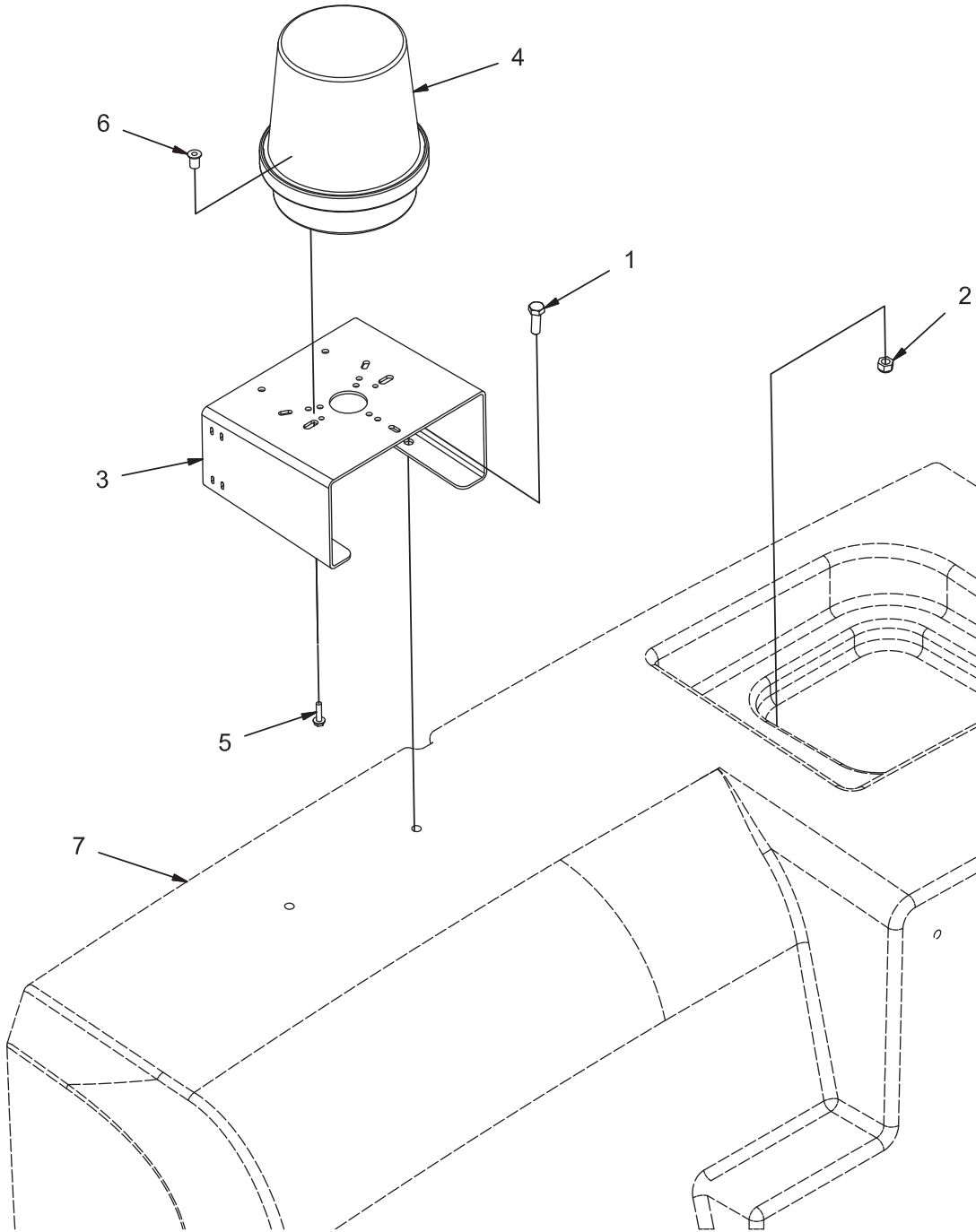

REV A

OPTION - LIGHT GROUP (ON SOLUTION TANK) (730189-4)

Parts List 730189-4			
ITEM	PART NUMBER	QTY	DESCRIPTION
1	11039567	2	BOLT, M8-1.25 X 25 HH SS
2	12040259	2	NUT, M8-1.25 ESN SS
3	731030	1	MOUNT, SAFETY LIGHTS
4	620073-1	1	LIGHT ASSY, LED BEACON
5	3400044	2	SCREW
6	3400172	2	NUT, EXPANSION
7	REF.	-	SOLUTION TANK
	748980	1	HARNESS, SAFETY LIGHT & BACKUP ALARM (NOT SHOWN)

OPTION - CHEMICAL METERING GROUP (730015)

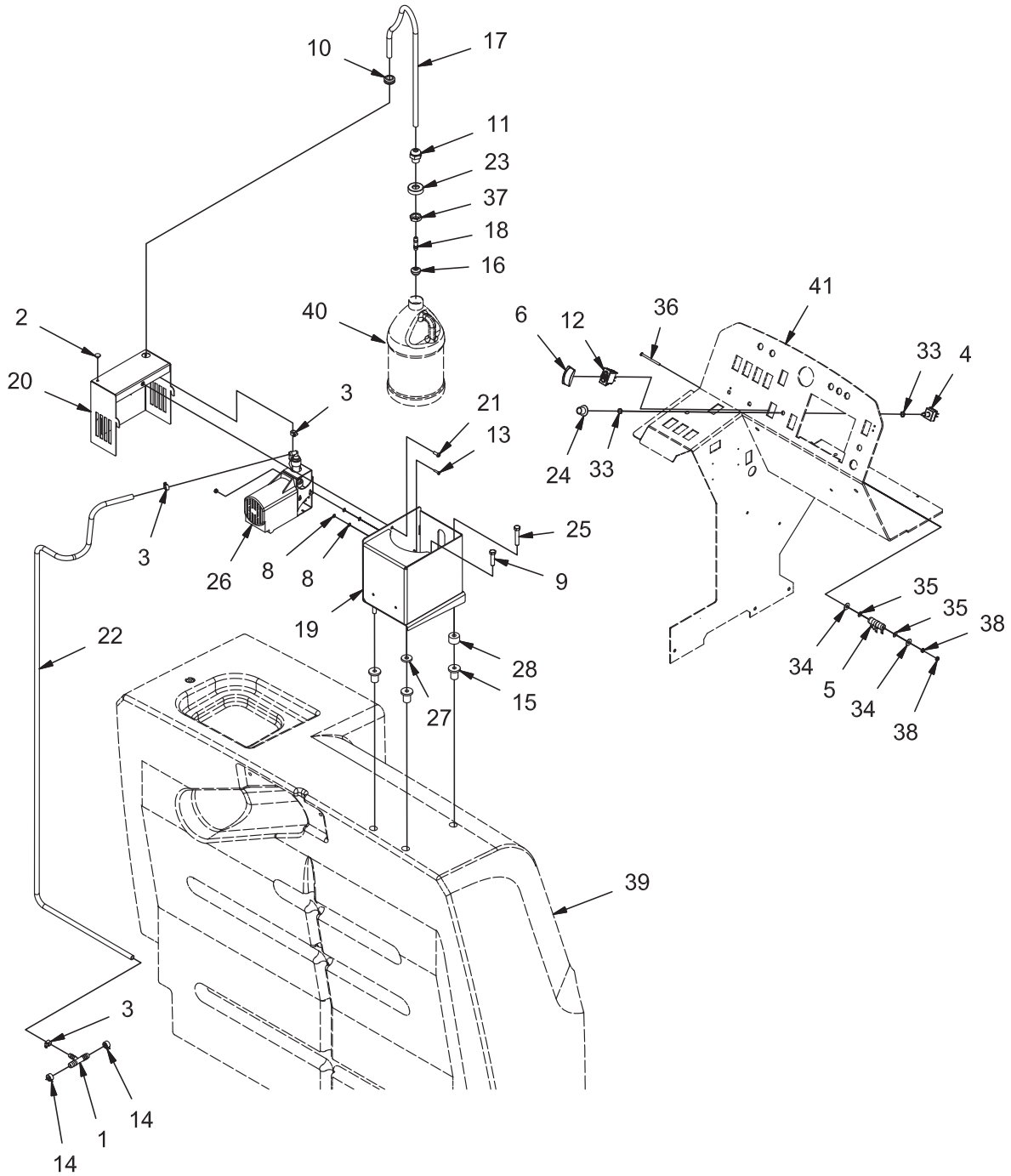

REV F

OPTION - CHEMICAL METERING GROUP (730015)

Parts List 730015			
ITEM	PART NUMBER	QTY	DESCRIPTION
1	172400	1	FITTING, TEE, .38 X .50 X .50 POLY
2	3300526	1	BUMPER, .25 ID .125 T
3	3302338	3	CLAMP, HOSE, .50
4	3303072	1	SWITCH, ROTARY, 4-WAY
5	3323992	1	RESISTOR
6	3344038	1	SWITCH COVER, BLACK
7	3400082	2	NUT, FIBER INSERT #8-32
8	3400096	4	FLATWASHER, #8
9	3400455	2	SCREW, 3/8-16 X 1.50 HH SS
10	600151	1	GROMMET, .63 ID .88 OD .25 T
11	600482	1	STRAIN RELIEF
12	620137	1	SWITCH BODY, DPST W/GREEN LAMP
13	710230	2	SCREW, #8-32 X .62 PAN HD
14	730962	2	CLAMP, WIRE HOSE
15	730991	3	NUT, RUBBER EXPANSION
16	731105	1	STAINER, SUCTION, 40 MESH
17	731106	1	TUBING, .375 ID X .06 WALL VINYL
18	731107	1	FITTING, .38 HOSE BARB COUPLING, NYLON
19	731111	1	WELDMENT, CHEMICAL PUMP MNT
20	731114-1	1	ASSEMBLY, PUMP COVER
21	731116	1	SCREW, M6-1.00 X 16 BUTTON HD CAP ZP
22	731117	1	TUBING, .375 ID X .06 WALL VINYL
23	PART OF 731120	1	CAP, CHEMICAL CONTAINER
24	731187	1	KNOB
25	731213	1	BOLT, 3/8-16 X 2.00 HH SS
26	731350	1	ASSEMBLY, METERING PUMP
27	731385	1	SPACER, .406 B 1.125 OD .188 T
28	731386	1	SPACER, .406 B 1.125 OD .750 T
29	748461	1	HARNESS ASSY, SPRAY PUMP
30	748462	1	HARNESS ASSY, SPRAY PUMP
31	748463	1	HARNESS ASSY, SPRAY PUMP
32	748464	1	WIRE ASSY
33	PART OF 3303072	2	NUT
34	PART OF 3323983	2	FLAT WASHER, .31
35	PART OF 3323983	2	WASHER, RIDGE
36	PART OF 3323983	1	SCREW, #10-32 X 2.63
37	PART OF 600482	1	NUT, PLASTIC
38	PART OF 3323983	2	NUT, #19-32
39	REF.	-	SOLUTION TANK
40	REF.	-	CHEMICAL CONTAINER
41	REF.	-	CONSOLE

OPTION - FIRE EXTINGUISHER GROUP (730016)

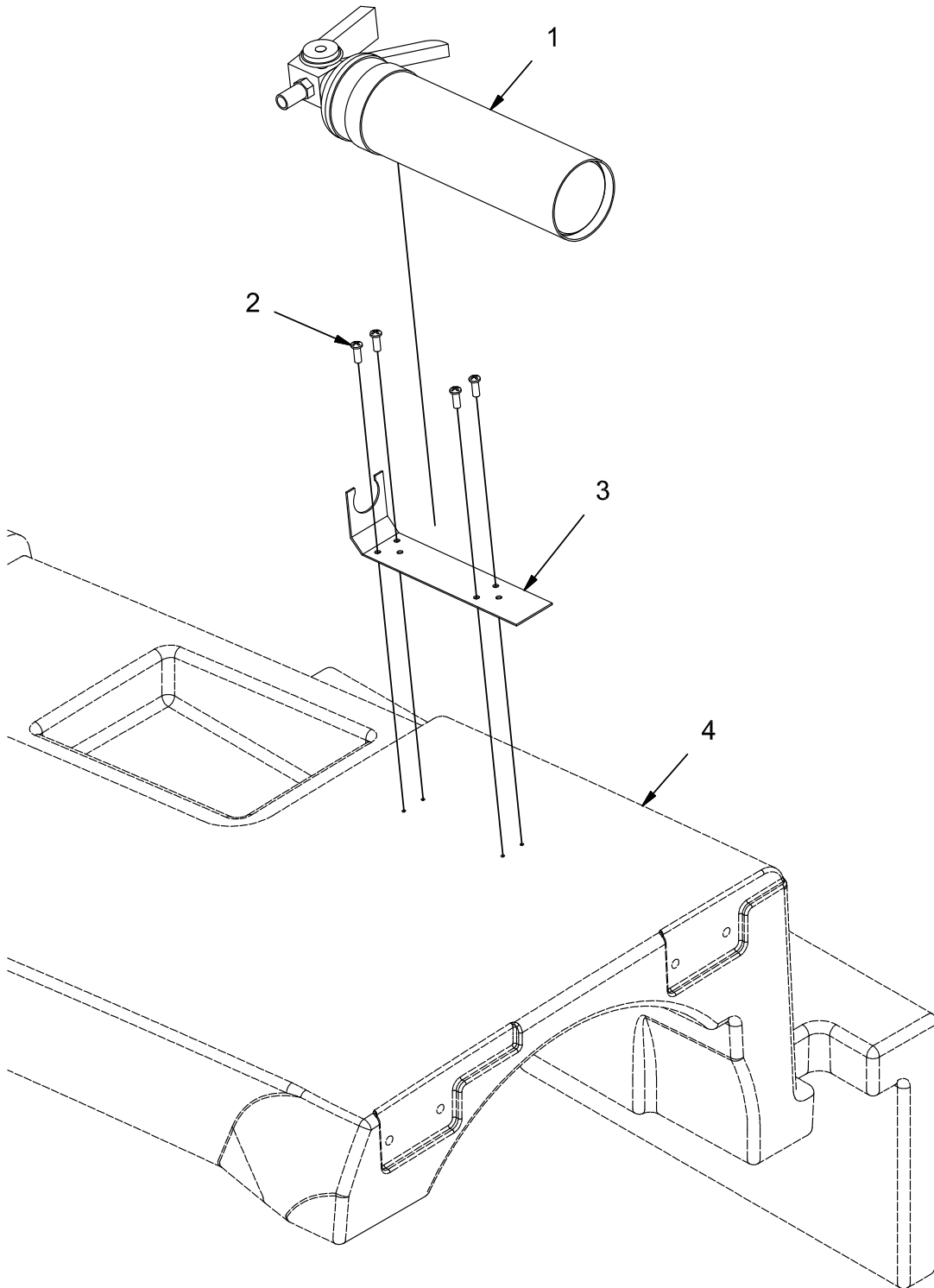

REV *

OPTION - FIRE EXTINGUISHER GROUP (730016)

Parts List 730016			
ITEM	PART NUMBER	QTY	DESCRIPTION
1	3302769	1	FIRE EXTINGUISHER
2	731099	4	SCREW, M6 X 16 PAN HD ZP FOR PLASTIC
3	PART OF 3302769	1	MOUNT, EXTINGUISHER
4	REF.	-	TOP COVER

OPTION - AUTO FILL GROUP (730017)

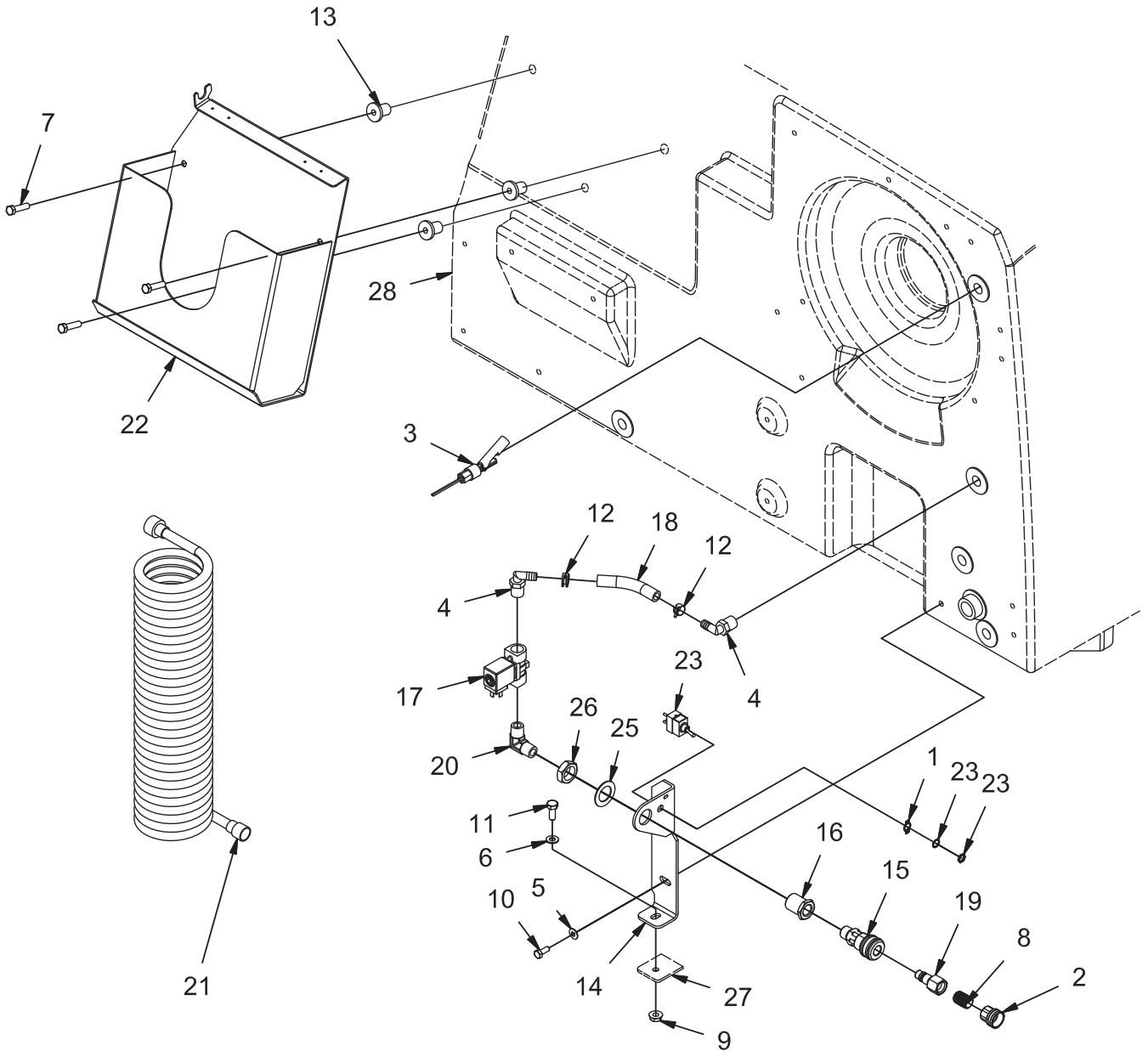

REV D

OPTION - AUTO FILL GROUP (730017)

Parts List 730017			
ITEM	PART NUMBER	QTY	DESCRIPTION
1	101020	1	INDICATOR PLATE
2	121109	1	SWIVEL-3/4" FGH X 1/2" BRASS
3	3302737-1	1	WIRE ASSY, SWITCH, FLOAT
4	3315535	2	FITTING, PLASTIC, 90, .50 NPT .50 BARB
5	3400384	1	WASHER, 5/16 BELLEVILLE
6	3400385	1	WASHER, 3/8, BELLEVILLE
7	3400455	3	SCREW, 3/8-16 X 1.50 HH SS
8	383465	1	FTG-NIPPLE 1/2 MPT X 1-1/8 LG BRASS
9	600936	1	NUT, M10-1.50 FLNG
10	717030	1	BOLT, M8-1.25 X 20 HH SS
11	730958	1	BOLT, M10-1.50 X 25 HH SS
12	730962	2	CLAMP, WIRE HOSE
13	730991	3	NUT, RUBBER EXPANSION
14	731042	1	BRACKET, AUTO FILL
15	731043	1	COUPLER, QUICK DISCONNECT
16	731044	1	FITTING, BULKHEAD COUPLING
17	731045	1	VALVE, SOLENOID WATER
18	731046	1	TUBING, .50 ID, VINYL
19	731048	1	FITTING, QUICK DISCONNECT NIPPLE
20	731049	1	FITTING, ELBOW
21	731383	1	HOSE, COIL, .38 ID X 50 FT
22	731437	1	WELDMENT, HOSE BOX
23	747693-1	1	SWITCH ASM, TOGGLE, SPDT
24	748989	1	HARNESS, AUTO FILL
25	PART OF 731044	1	WASHER
26	PART OF 731044	1	NUT
27	REF.	-	FRAME
28	REF.	-	SOLUTION TANK

OPTION - SPRAY AND VAC WAND TOOL GROUP (730021 - PART 1)

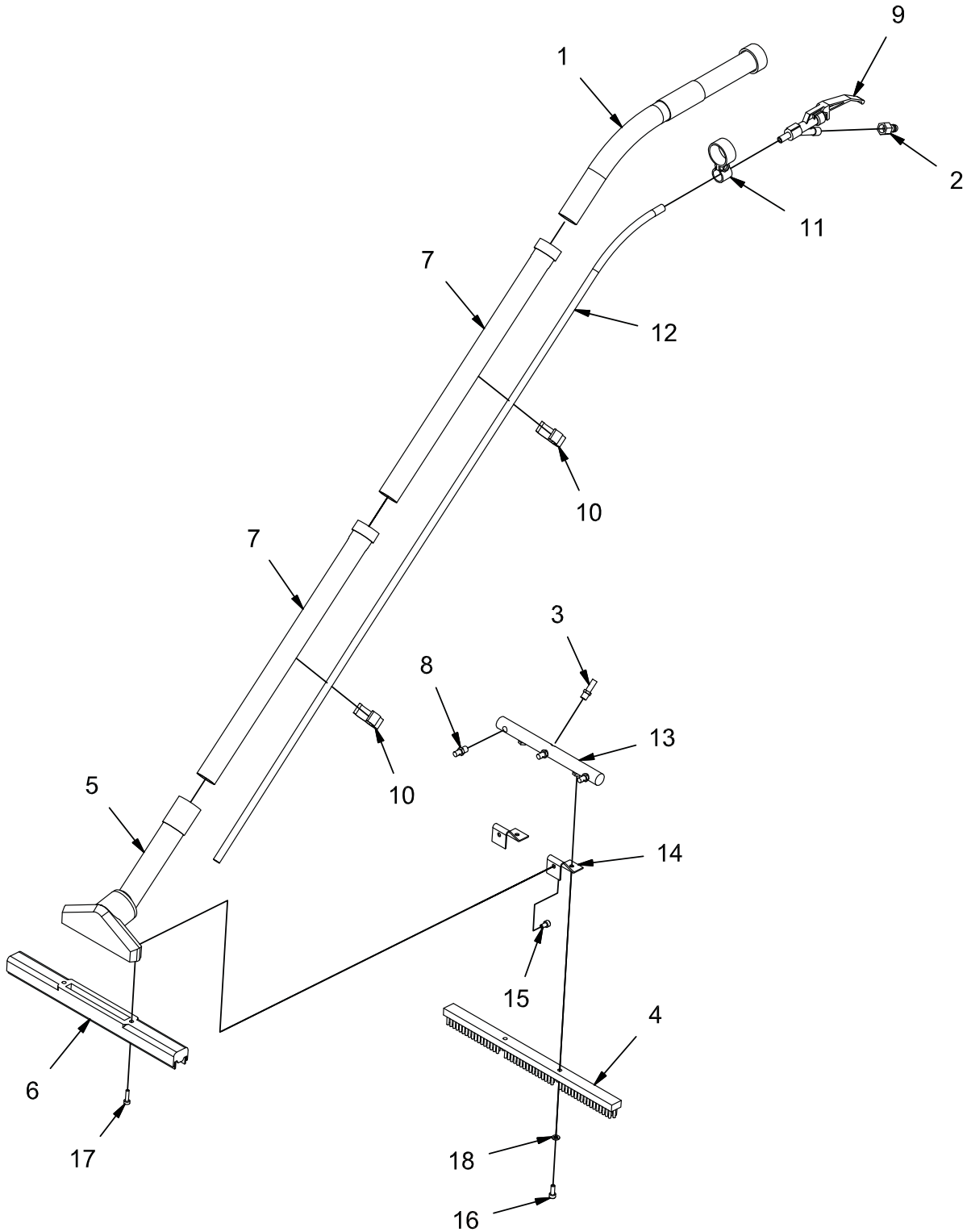

REV *

OPTION - SPRAY AND VAC WAND TOOL GROUP (730021 PART 1)

Parts List 730021			
ITEM	PART NUMBER	QTY	DESCRIPTION
1	-	1	UPPER TUBE - AVAILABLE ON REQUEST
2	00054440	1	FITTING, MALE QUICK DISCONNECT
3	00054450	1	FITTING, HOSE BARB
4	00112340	1	BRUSH STRIP
5	00112350	1	NOZZLE BODY
6	00112360	1	SQUEEGEE BLADE
7	00442330	2	TUBE
8	00501580	3	SPRAY NOZZLE
9	00552250	1	VALVE
10	00552410	2	CLIP, HOSE
11	00552440	1	BRACKET, PIPE
12	00704720	1	HOSE, SOLUTION
13	00704730	1	BLAST PIPE
14	03500300	2	BRACKET, RETAINER
15	11126018	2	BOLT, M6 X 10 AHCS
16	11126166	2	SCREW, CYL HD, M6 X 16
17	11405040	2	SCREW, SELF TAPPING 4,8 X 19
18	12310033	2	WASHER, M6
-	99700900	1	COMPLETE WAND

**GROUP (730030) - OPTION SPRAY AND VAC WAND, INCLUDES SUB-GROUPS:
730021, 730022, 730023.**

OPTION - SPRAY AND VAC WAND HOSE GROUP (730021 PART 2)

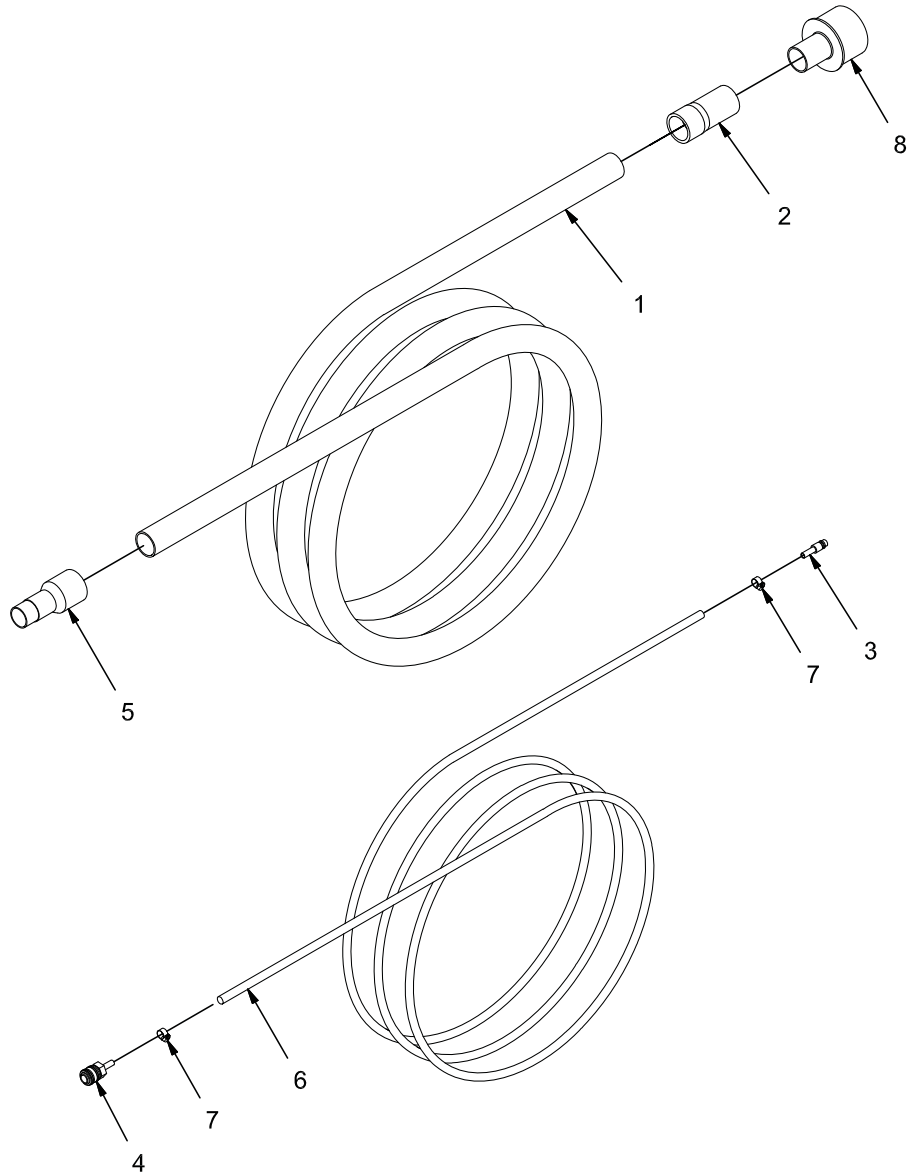

REV *

OPTION - SPRAY AND VAC WAND HOSE GROUP (730021 PART 2)

Parts List 730021			
ITEM	PART NUMBER	QTY	DESCRIPTION
1	00010670	1	ASSEMBLY, VACUUM HOSE
2	00101280	1	HOSE CUFF. FEMALE
3	00552380	1	MALE QUICK DISCONNECT
4	00552400	1	FEMALE QUICK DISCONNECT
5	00782240	1	HOSE CUFF, MALE
6	01074690	1	ASSEMBLY, PRESSURE HOSE
7	17533100	2	CLAMP, HOSE
8	731098	1	ADAPTER, HOSE
-	99776600	1	COMPLETE KIT LESS 731098 ADAPTER

**GROUP (730030) - OPTION SPRAY AND VAC WAND, INCLUDES SUB-GROUPS:
730021, 730022, 730023.**

OPTION - SPRAY AND VAC WAND MOUNT GROUP (730022)

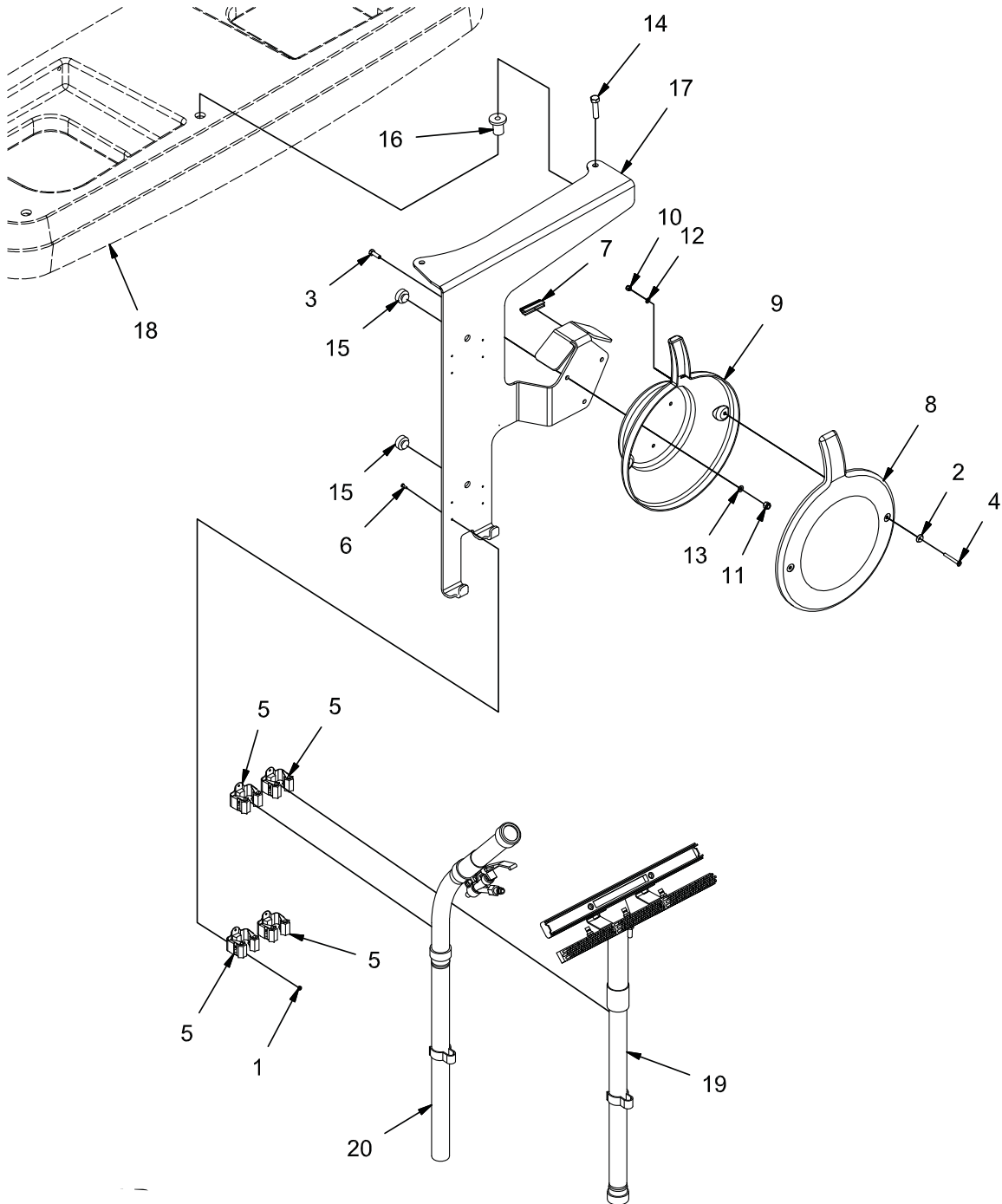

REV B

OPTION - SPRAY AND VAC WAND MOUNT GROUP (730022)

Parts List 730022			
ITEM	PART NUMBER	QTY	DESCRIPTION
1	00022200	8	NUT, ESN
2	00076210	2	WASHER, DECORATIVE
3	00154070	3	BOLT, M6
4	00523440	2	SCREW, FLAT HD
5	00560010	4	CLAMP
6	00695680	8	SCREW, PHILLIPS
7	00800100	1	EDGING
8	01090890	1	HOSE MOUNT, COVER
9	01090900	1	HOSE MOUNT, HALF SHELL
10	12040036	2	NUT, M5 - 0.8 ESN
11	12040044	3	NUT, M6-1.00 ESN
12	12310025	2	WASHER, M5
13	12310033	6	WASHER, M6
14	3400455	2	SCREW, 3/8-16 X 1.50 HH SS
15	600117	2	BUMPER, 1.00 X .339 T
16	730991	2	NUT, RUBBER EXPANSION
17	731097	1	BRACKET, HOSE MOUNT
18	REF.	-	DEMISTER
19	REF.	-	LOWER VAC WAND ASSEMBLY
20	REF.	-	UPPER VAC WAND ASSEMBLY

**GROUP (730030) - OPTION SPRAY AND VAC WAND, INCLUDES SUB-GROUPS:
730021, 730022, 730023.**

OPTION - SPRAY AND VAC WAND PUMP GROUP (730023)

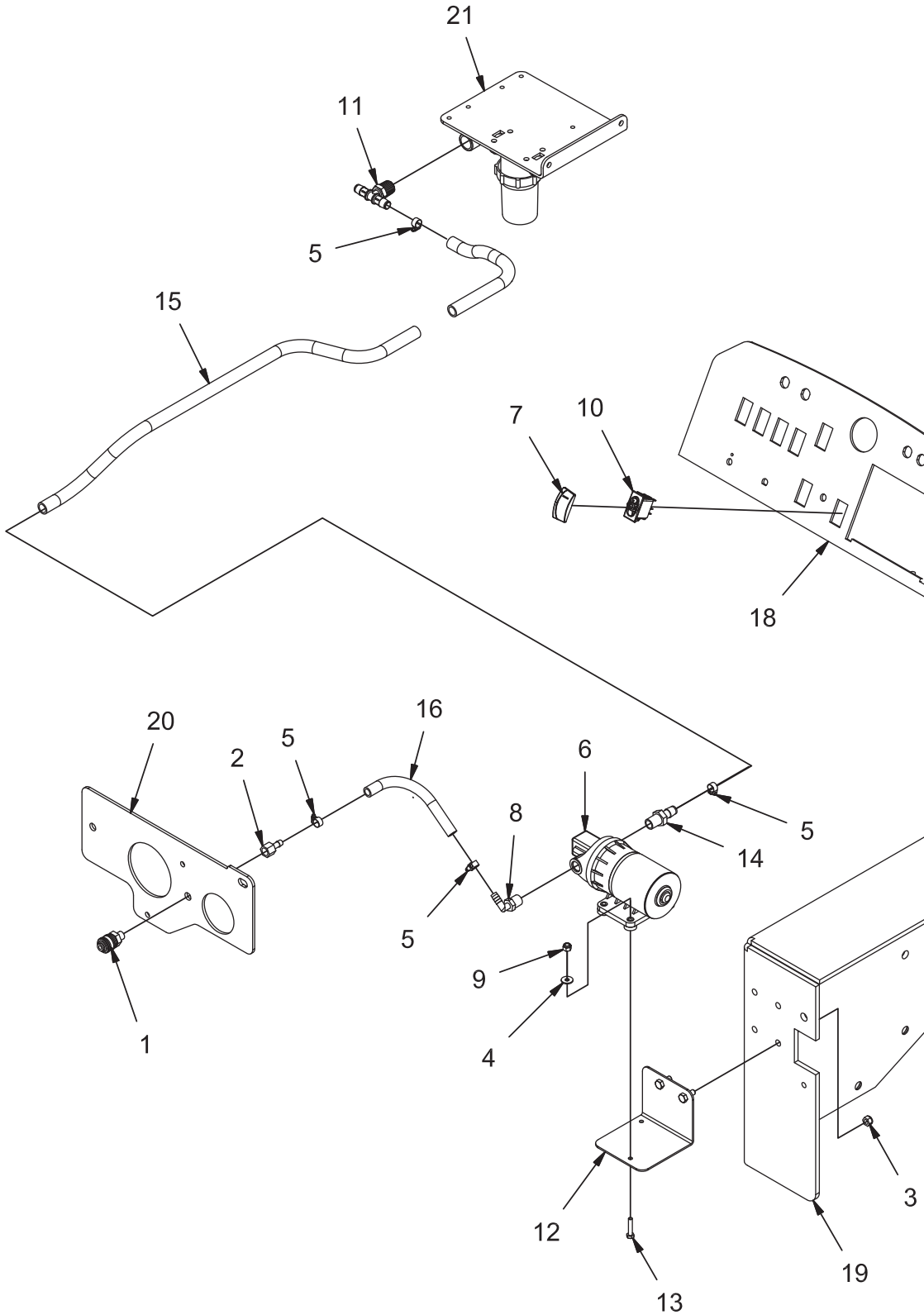

REV B

OPTION - SPRAY AND VAC WAND PUMP GROUP (730023)

Parts List 730023			
ITEM	PART NUMBER	QTY	DESCRIPTION
1	00552590	1	FEMALE QUICK DISCONNECT
2	00552600	1	FITTING, BARB
3	12040259	2	NUT, M8-1.25 ESN SS
4	12332011	2	WASHER, FENDER, M6
5	3302338	4	CLAMP, HOSE, .50
6	3331278	1	PUMP, SOLUTION
7	3344038	1	SWITCH COVER - BLACK, NO LENS
8	3400985	1	FITTING, PLASTIC, 90, .375 NPT .375 BARB
9	600933	2	NUT, M6-1.00 ESN SS
10	620137	1	SWITCH BODY, DPST W/GREEN LAMP
11	730969	1	FITTING, TEE, .50 NPT - .50 BARB, NYLON
12	731038	1	WELDMENT, PUMP MNT
13	731050	2	BOLT, M6-100 X 30 HH SS
14	731094	1	FITTING, STR, 1/2 BARB X 3/8 MALE NPT
15	731095	1	TUBING, .50 ID VINYL
16	731096	1	TUBING, .375 ID VINYL
17	748797	1	HARNESS, OAW PUMP OPT
18	REF.	-	INST PANEL
19	REF.	-	FRAME
20	REF.	-	VALVE MOUNT PLT
21	REF.	-	FILTER MNT BRACKET

**GROUP (730030) - OPTION SPRAY AND VAC WAND, INCLUDES SUB-GROUPS:
730021, 730022, 730023.**

OPTION - URETHANE SQUEEGEE BLADE GROUP (730024)

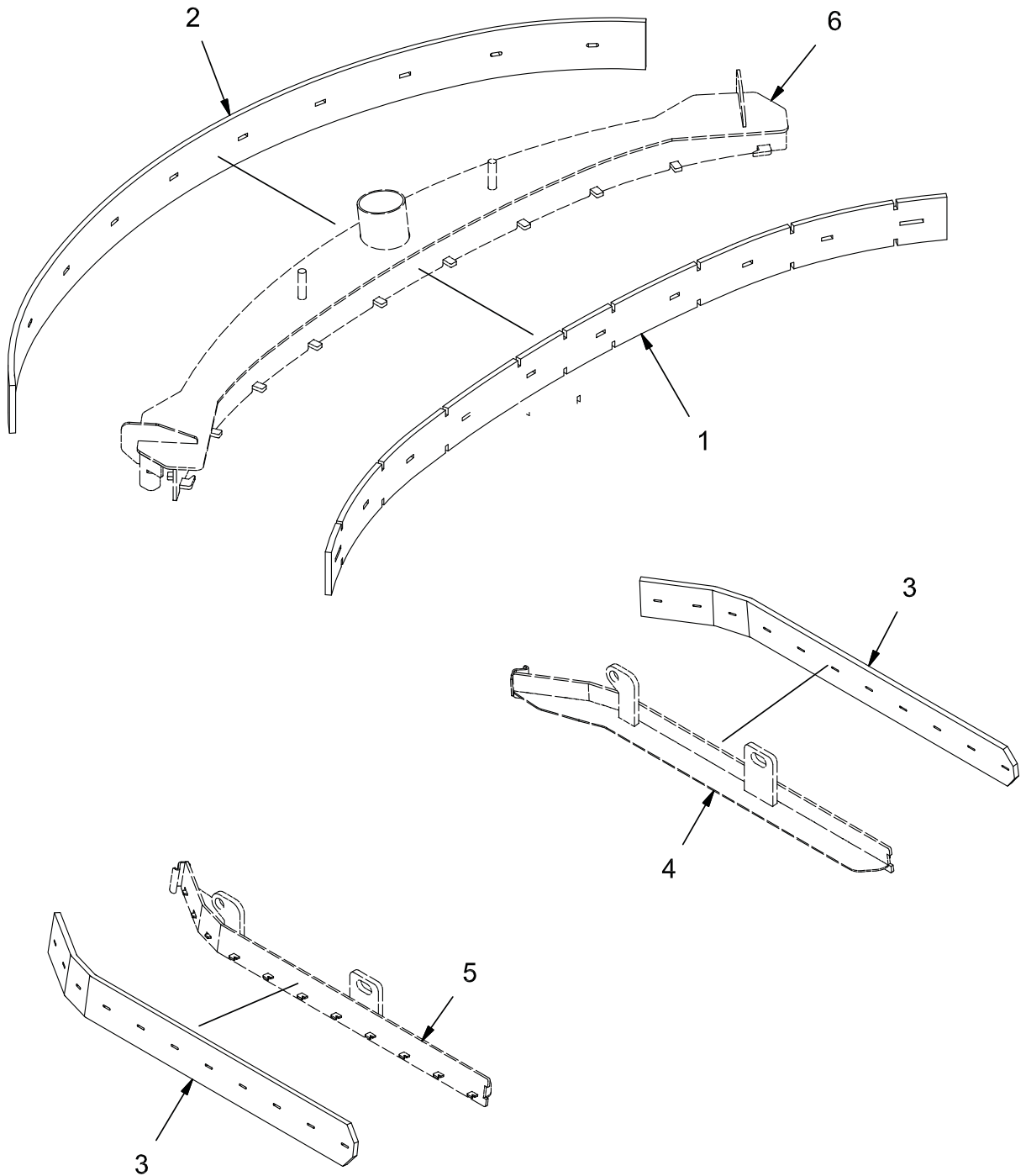

REV *

OPTION - URETHANE SQUEEGEE BLADE GROUP (730024)

Parts List 730024			
ITEM	PART NUMBER	QTY	DESCRIPTION
1	731101	1	SQUEEGEE BLADE, FRONT, URETHANE
2	731102	1	SQUEEGEE BLADE, REAR, URETHANE
3	731103	2	SQUEEGEE, SIDE, URETHANE
4	REF.	-	LH SQUEEGEE MOUNT
5	REF.	-	RH SQUEEGEE MOUNT
6	REF.	-	SQUEEGEE WELDMENT

OPTION - URETHANE SIDE BRUSH SQUEEGEE GROUP (730025)

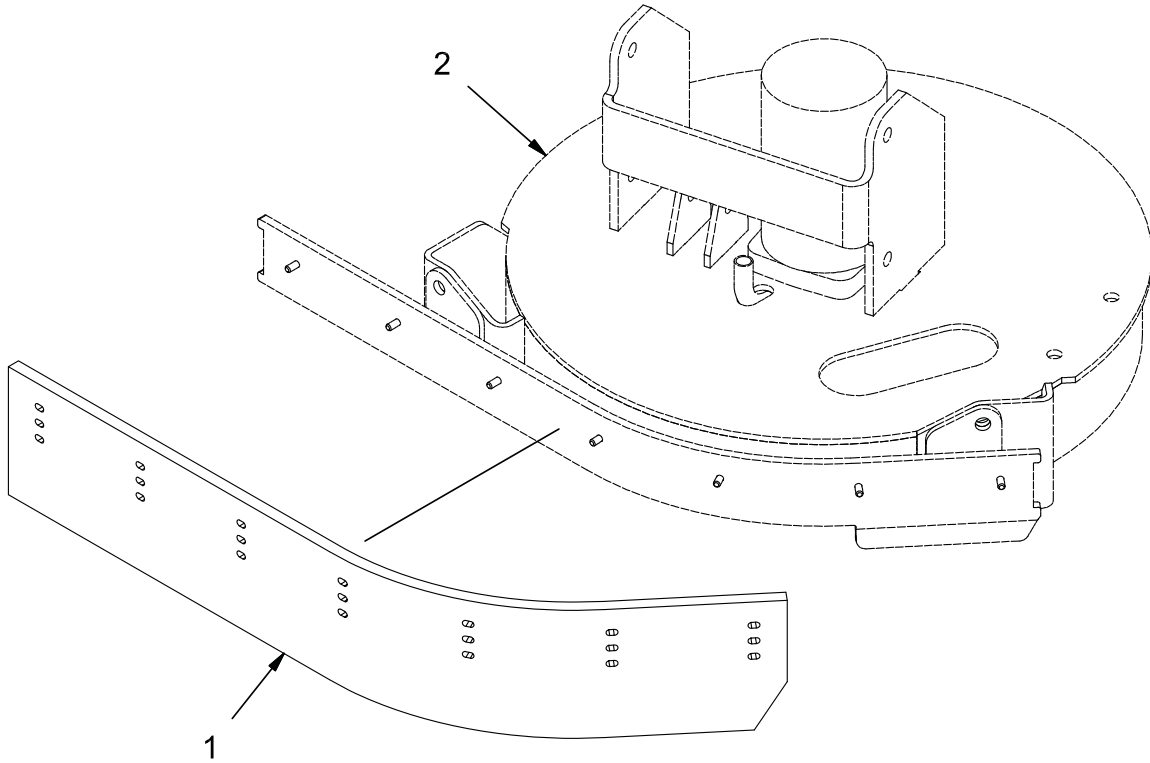

REV *

OPTION - URETHANE SIDE BRUSH SQUEEGEE GROUP (730025)

Parts List 730025			
ITEM	PART NUMBER	QTY	DESCRIPTION
1	731104	1	SSB SQUEEGEE BLADE, URETHANE
2	REF.	-	SSB MOUNT

OPTION - STAINLESS STEEL HOPPER GROUP (730027)

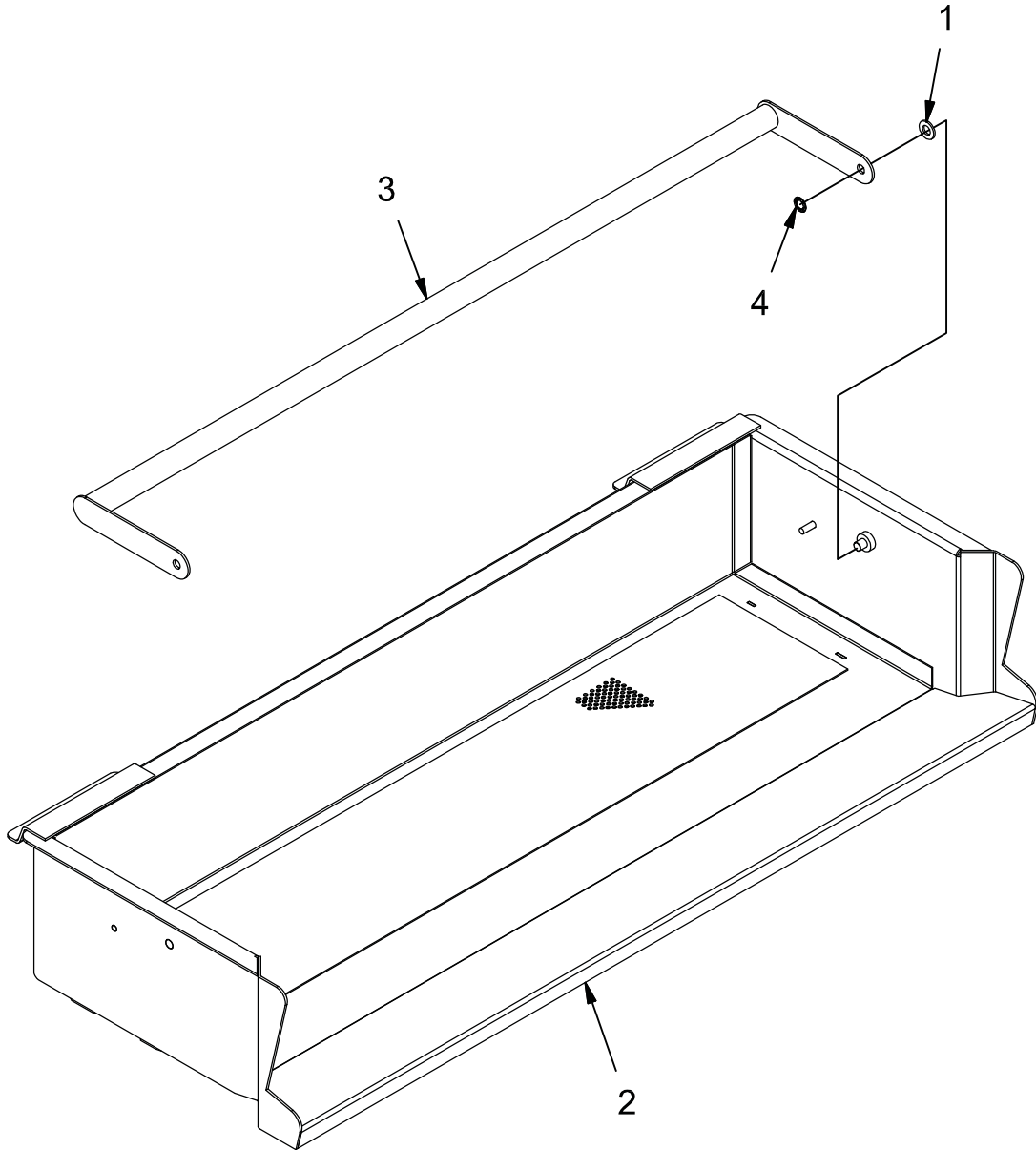

REV *

OPTION - STAINLESS STEEL HOPPER GROUP (730027)

Parts List 730124			
ITEM	PART NUMBER	QTY	DESCRIPTION
1	730344	2	WASHER, M10 SS
2	730815	1	WELDMENT, HOPPER
3	730835	1	WELDMENT, HANDLE
4	730844	2	RETAINING CLIP, .375 SS

**OPTION - SEAT SWITCH (730031)
STANDARD ON CE AND UK MODELS**

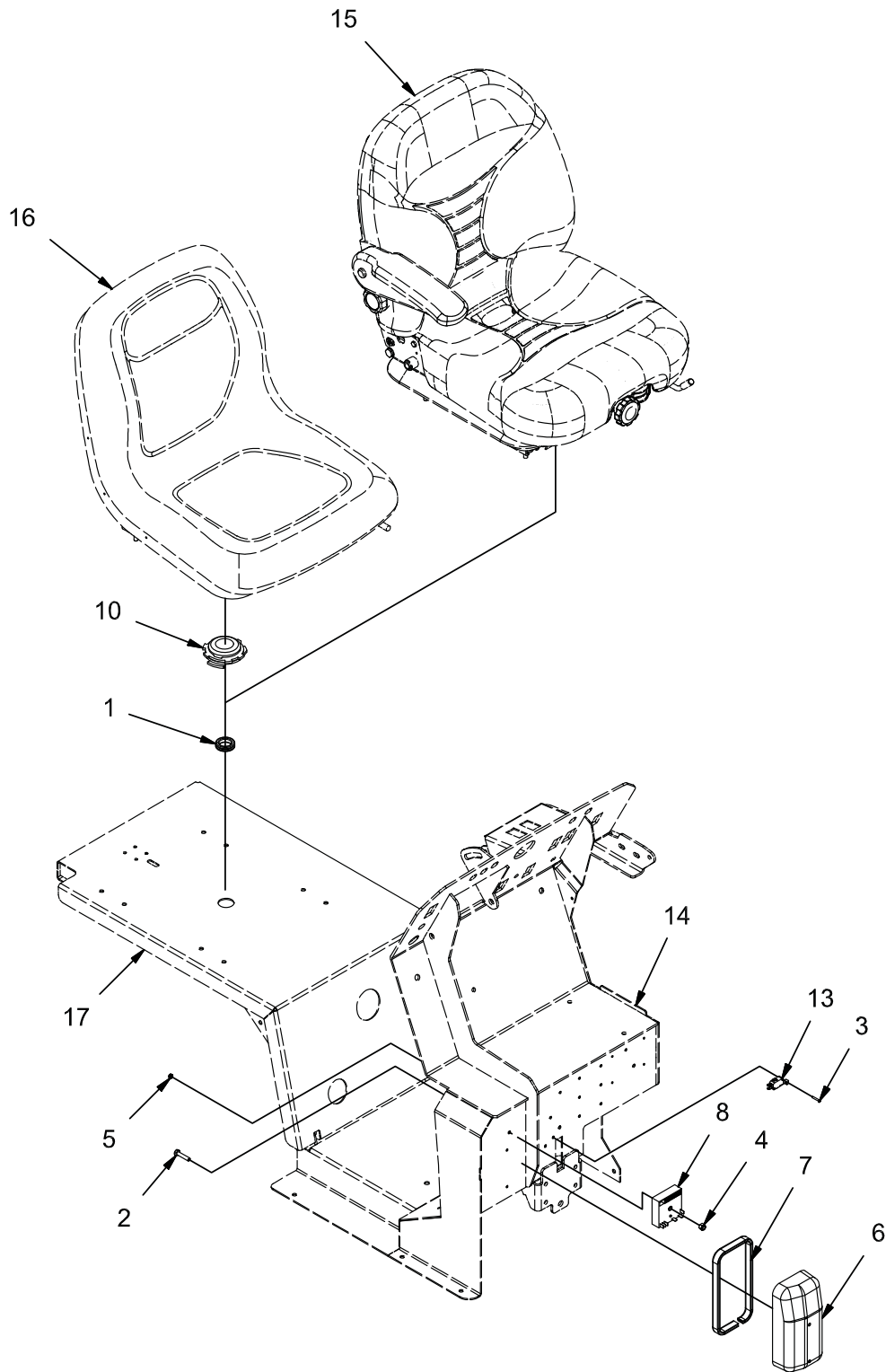

REV A

OPTION - SEAT SWITCH (730031)

Parts List 730031			
ITEM	PART NUMBER	QTY	DESCRIPTION
-	748456	1	HARNESS, SWITCH BYPASS
-	748444	1	STD SEAT SWITCH HARNESS
1	220327	1	GROMMET. 1.25 X 1.00 X .125
2	3400227	1	SCREW, 1/4-20 X 1.25 HH ZP
3	710493	2	SCR-MC RND HD 4-40 X .75 ZP
4	711373	1	NUT, FIBER INSERT 1/4-20
5	712348	2	NUT, HEX 4-40 NYLON LOCK, ZP
6	731275	1	COVER, TIMER/CONTROLLER
7	731276	1	SEAL, CONTROLLER
8	748430	1	TIMER
10	748445	1	SWITCH - N/O TWIST LOCK (USED WITH STANDARD SEAT ONLY)
12	748999	1	SEAT SWITCH HARNESS
13	90636234	1	MICRO-SWITCH
14	REF.	-	CONSOLE
15	REF.	-	OPTIONAL SUSPENSION SEAT
16	REF.	-	STANDARD SEAT
17	REF.	-	SEAT MNT

OPTION - SIDE BROOM GROUP (730032)

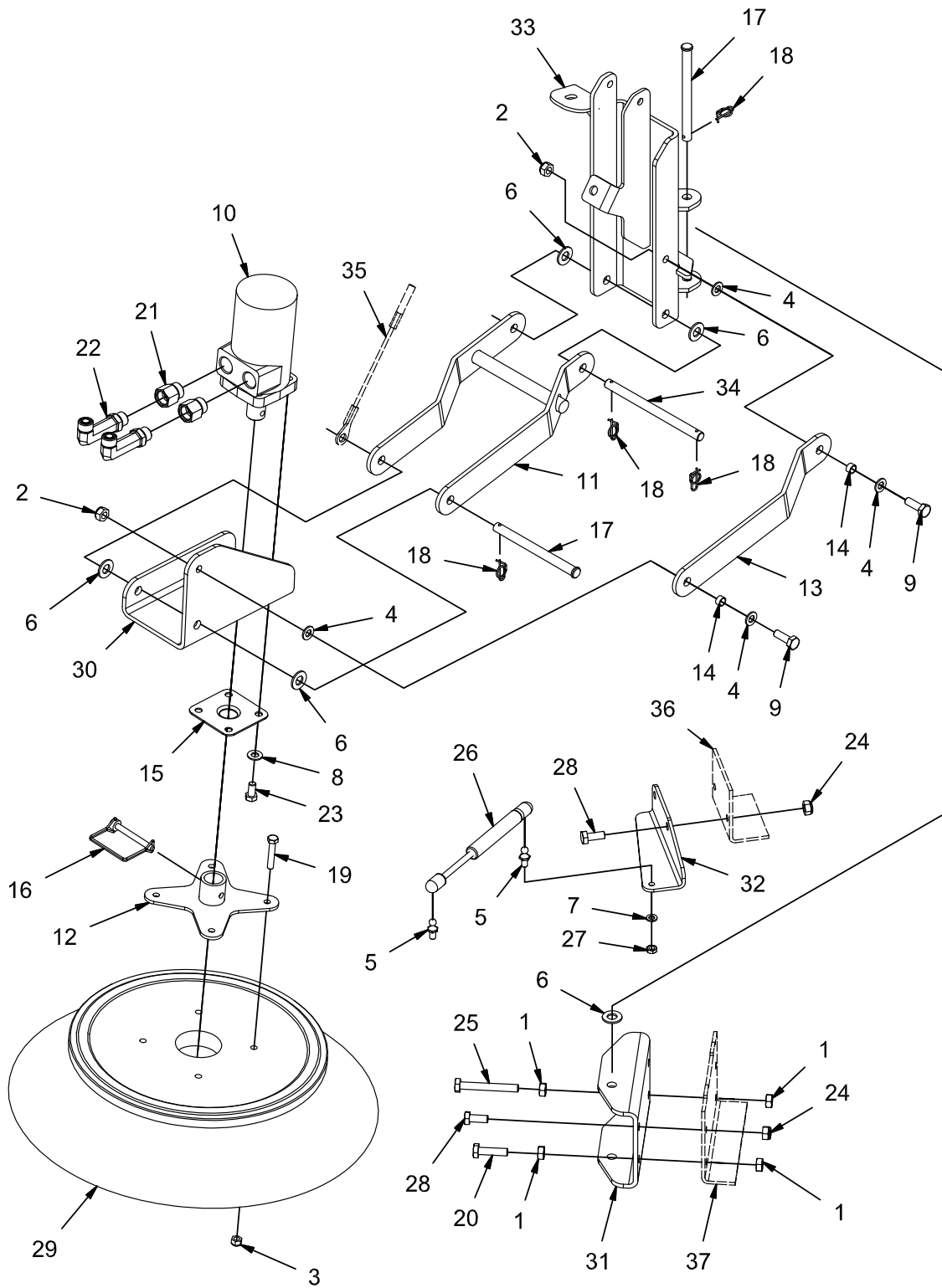

REV *

OPTION - SIDE BROOM GROUP (730032)

Parts List 730032			
ITEM	PART NUMBER	QTY	DESCRIPTION
1	12022067	4	NUT, M10-1.50 HEX
2	12040069	2	NUT, M10-1.50 ESN
3	12040259	4	NUT, M8-1.25 ESN SS
4	12310058	4	WASHER, M10
5	3300376	2	STUD, 10MM BALL
6	3400086	5	WASHER, 1/2, 1.063 X .531 X .094
7	3400102	2	LOCK WASHER, 5/16 HS MED
8	3400385	4	WASHER, 3/8, BELLEVILLE
9	3401051	2	BOLT, M10-1.50 X 30 HH
10	600217	1	MOTOR, 17.9 DISP
11	600303	1	WELDMENT, SB TRAILING ARM
12	600322	1	WELDMENT, SB FLANGE
13	600325	1	SB LINK
14	600327	2	SPACER, .406 B .50 OD .280 T
15	600330	1	STRING GUARD
16	600566	1	PIN, WIRE LOCK, .313
17	600571	2	PIN, CLEVIS 1/2 X 6.00
18	600578	4	RUE-RING, .50
19	600820	4	BOLT, M8-1.25 X 45 HH
20	600962	1	BOLT, M10-1.50 X 40 HH FULL THRD
21	3400166	2	FITTING, REDUCER -10 SAE -8 SAE
22	675606	2	FITTING, LONG ELBOW -8 ORFS -8 SAE
23	713041	4	SCREW, 3/8-16 X .750 HHC
24	730339	4	NUT, M10-1.50 ESN SS
25	730424	1	BOLT, M10-1.50 X 80 HH ALL-THRD
26	730902	1	GAS STRUT, 8.77 EXT, 3.00 STK, 200N
27	730904	2	NUT, 5/16-18 HEX JAM SS
28	730958	4	BOLT, M10-1.50 X 25 HH SS
29	731274	1	BROOM, SIDE, 20"
30	731278	1	MOUNT, SB MOTOR
31	731279	1	MOUNT, SB PIVOT
32	731280	1	MOUNT, SB GAS STRUT
33	731285	1	WELDMENT, SB PIVOT
34	731290	1	PIN, RETAINING
35	REF.	-	SB CABLE
36	REF.	-	FRAME
37	REF.	-	FRAME

**GROUP (730037) - OPTION SIDE BROOM, INCLUDES SUB-GROUPS:
730032, 730033, 730034, 730028, 730029**

OPTION - SIDE BROOM LIFT AND ADJUSTMENT GROUP (730033)

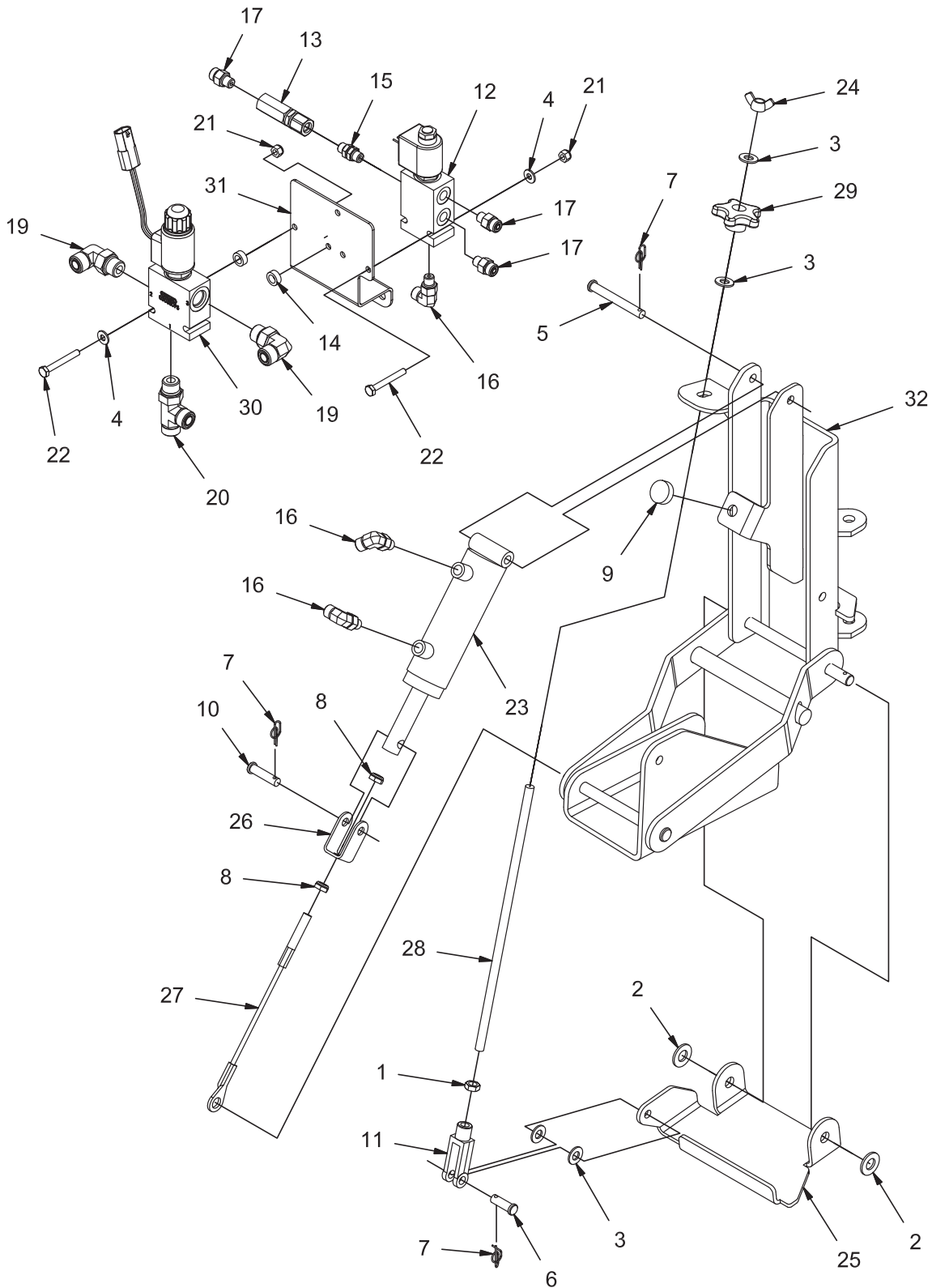

REV C

OPTION - SIDE BROOM LIFT AND ADJUSTMENT GROUP (730033)

Parts List 730033			
ITEM	PART NUMBER	QTY	DESCRIPTION
1	3400075	1	NUT, HEX JAM 3/8-24
2	3400086	6	WASHER, 1/2, 1.063 X .531 X .094
3	3400087	4	WASHER, 3/8
4	3400089	4	WASHER, 1/4 .625 X .281 X .063
5	3400115	1	PIN, CLEVIS, .375 X 3.00
6	3400117	1	PIN, CLEVIS 3/8 X 1.125
7	3400125	3	RUE-RING, .375
8	3401028	2	NUT, FIBER INSERT 3/8-16 JAM
9	600117	1	BUMPER, 1.00 X .339 T
10	600573	1	PIN, CLEVIS, 3/8 X 1.50
11	600813	1	CLEVIS, 3/8-24
12	620005	1	SOLENOID, 2-POS, 4-WAY, CROSSOVER
13	620008	1	CHECK VALVE
14	620009	2	SPACER, .391 B .750 OD .250 T
15	620110	1	ADAPTER, #4 O-RING - #4 O-RING
16	675507	3	FITTING, 90, -4 ORFS - 4 SAE
17	675508	3	FITTING, STR, 4 ORFS - 4-SAE
19	675523	2	FITTING, 90, -8 ORFS - 8 SAE
20	675525	1	FITTING, RUN TEE, 8 ORFS - 8 ORFS - 8 SAE
21	711373	4	NUT, FIBER INSERT 1/4-20
22	712567	4	SCREW, 1/4-20 X 2.00 HH SS
23	730548	1	CYLINDER, HYD, 1.50 B X 2.88 STK
24	731277	1	WING NUT, 3/8-24, NYLON
25	731281	1	CHANNEL, SB ADJUSTMENT
26	731282	1	CLEVIS, CABLE
27	731283	1	SB CABLE
28	731284	1	ROD, SB ADJUSTMENT
29	731291	1	KNOB, 3/8-24
30	731292	1	ASSEMBLY, SOLENOID VALVE 2-POS 3-WAY
31	770486	1	MOUNT, SOLENOID
32	REF.	-	PIVOT ASSEMBLY

**GROUP (730037) - OPTION SIDE BROOM, INCLUDES SUB-GROUPS:
730032, 730033, 730034, 730028, 730029**

OPTION - SIDE BROOM HYDRAULIC HOSE GROUP (730034)

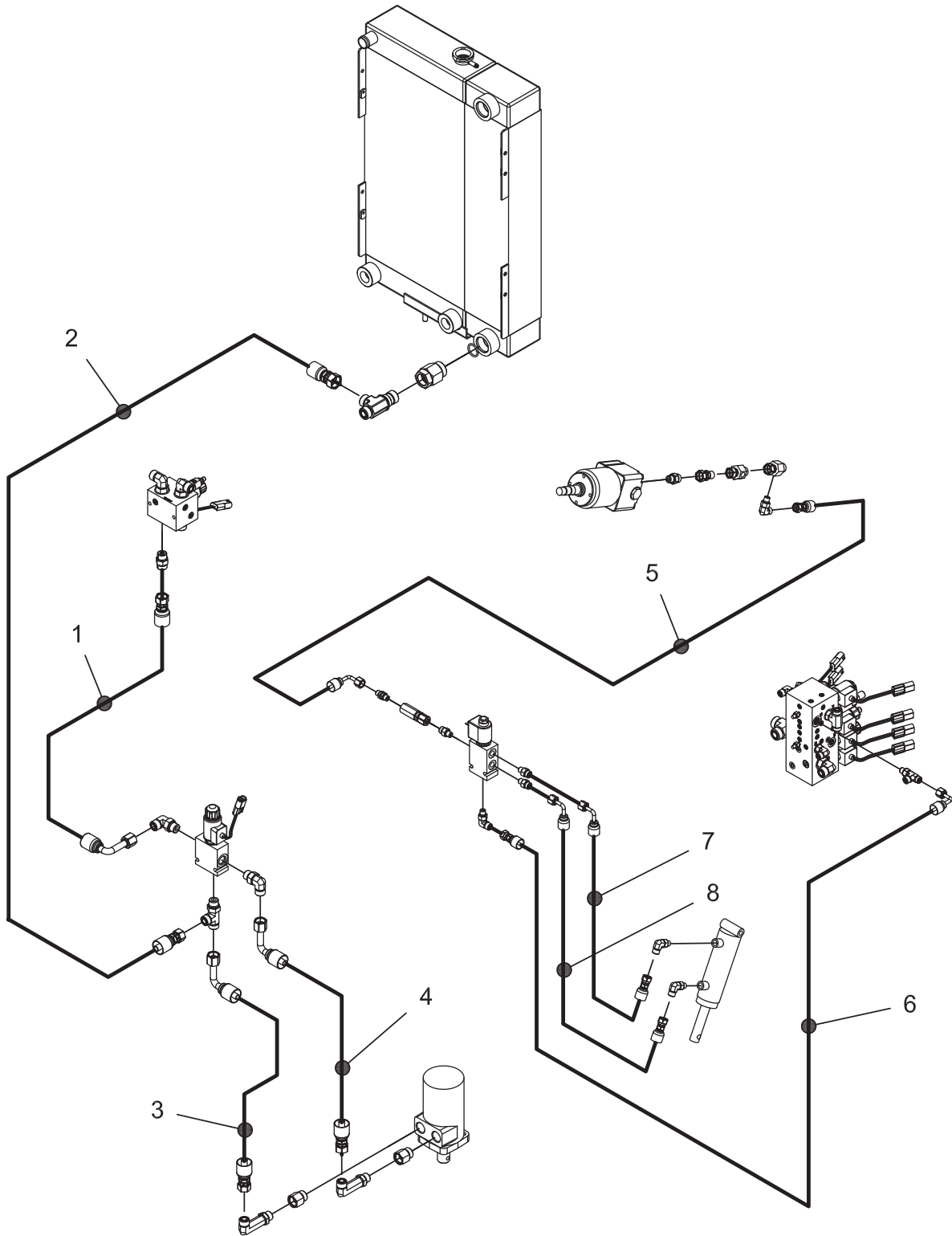

REV B

OPTION - SIDE BROOM HYDRAULIC HOSE GROUP (730034)

Parts List			
ITEM	PART NUMBER	QTY	DESCRIPTION
1	731500	1	HOSE, 8 STR - 8 90 MED (IMP SOL T TO SB MOTOR SOL 2)
2	REF.	-	EXISTING HOSE - 731057
3	675470	1	HOSE, 8 STR - 8 90 MED (SB MOTOR SOL 1 TO SB LEFT)
4	675470	1	HOSE, 8 STR - 8 90 MED (SB MOTOR SOL 3 TO SB RIGHT)
5	731084	1	HOSE, 4 STR - 4 90 MED (STEERING UNIT PRESS TO CYL SOL 3)
6	731075	1	HOSE, 4 STR - 4 90 MED (CYL SOL 1 TO MAIN MANIFOLD T1)
7	731085	1	HOSE, 4 STR - 4 90 MED (CYL SOL 4 TO CYL PISTON END)
8	731085	1	HOSE, 4 STR - 4 90 MED (CYL SOL 2 TO CYL BASE END)

**GROUP (730037) - OPTION SIDE BROOM, INCLUDES SUB-GROUPS:
730032, 730033, 730034, 730028, 730029**

OPTION - SIDE BRUSH HYDRAULIC HOSE ROUTING (730038)

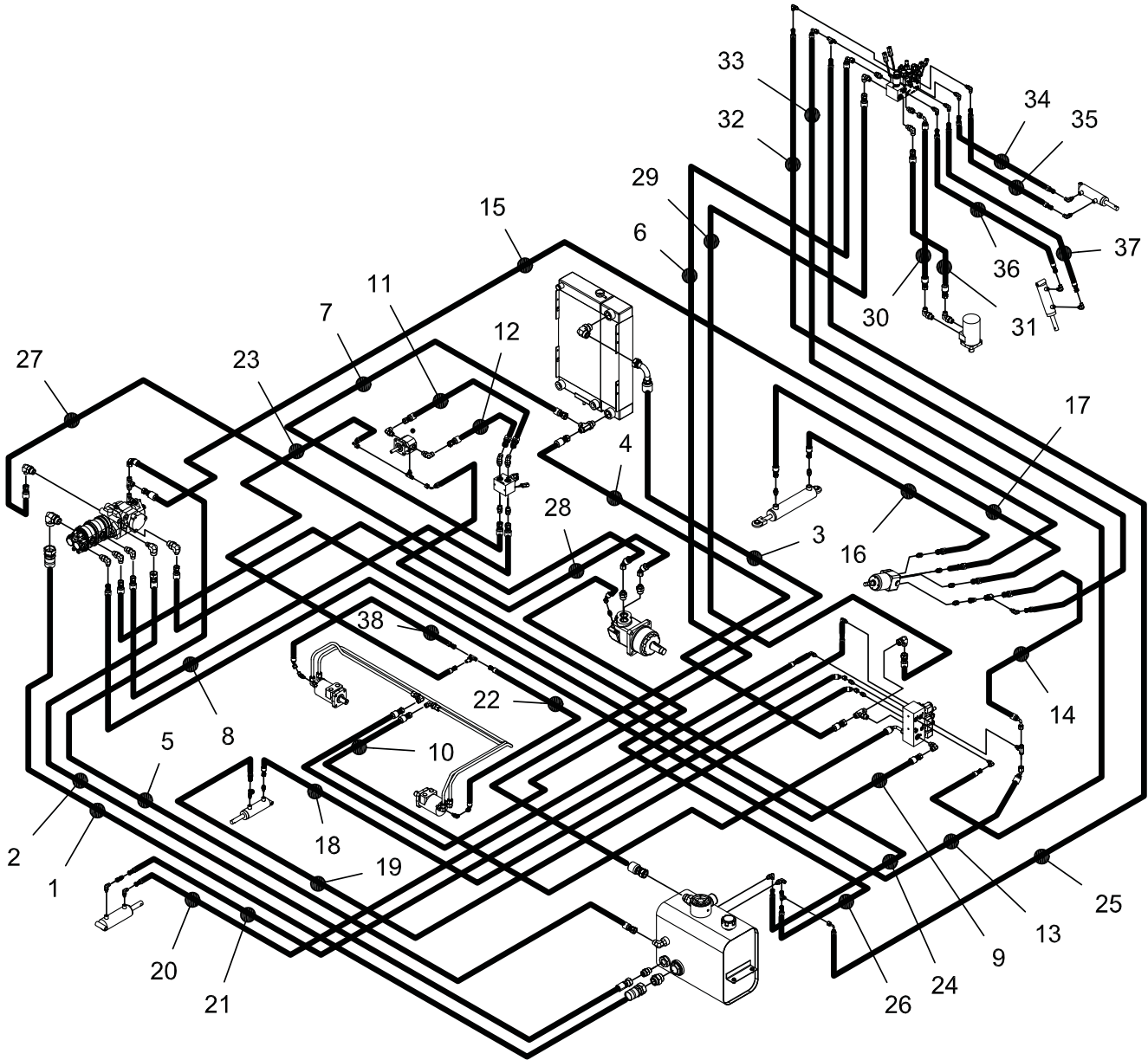

REV B

OPTION - SIDE BRUSH HYDRAULIC HOSE ROUTING (730038)

Parts List 730038			
ITEM	PART NUMBER	QTY	DESCRIPTION
1	731051	1	HOSE, 20 STR - 20 STR SUC (RES TO AUX PUMP IN)
2	731052	1	HOSE, 12 STR - 12 STR SUC (RES TO VDP CASE)
3	731053	1	HOSE, 16 STR - 16 90 RET (COOLER UPPER TO RES)
4	731054	1	HOSE, 10 STR - 10 STR RET (VALVE T2 TO COOLER)
5	731055	1	HOSE, 10 STR - 8 90 RET (VDP CASE TO RES)
6	731079	1	HOSE, 8 STR - 8 90 MED (LH MB TO SSB VALVE P2)
7	731057	1	HOSE, 8 STR - 10 STR MED (IMP SOL T TO COOLER)
8	731058	1	HOSE, 8 STR - 8 STR MED (AUX PUMP 1 TO IMP SOL P)
9	731059	1	HOSE, 8 STR - 8 STR MED (AUX PUMP 2 TO VALVE P2)
10	731060	1	HOSE, 8 STR - 8 90 MED (VALVE MB OUT TO MB RIGHT)
11	731061	1	HOSE, 8 STR - 8 90 MED (IMP SOL VF OUT TO IMP LEFT)
12	731062	1	HOSE, 8 STR - 8 90 MED (IMP RIGHT TO IMP SOL VF IN)
13	731063	1	HOSE, 6 STR - 6 90 MED (AUX PUMP 3 TO VALVE P1)
14	731064	1	HOSE, 6 STR - 6 90 MED (VALVE P1 TO STR PRESS)
15	731065	1	HOSE, 6 STR - 8 STR RET (STR TANK TO VDP CASE)
16	731066	1	HOSE, 6 STR - 6 STR MED (STR LEFT TO CYL F)
17	731067	1	HOSE, 6 STR - 6 STR MED (STR RIGHT TO CYL R)
18	731068	1	HOSE, 4 STR - 4 45 MED (VALVE BL A TO SH CYL F)
19	731069	1	HOSE, 4 STR - 4 45 MED (VALVE BL A TO SH CYL R)
20	731070	1	HOSE, 4 STR - 4 STR MED (VALVE SG B TO SQU CYL F)
21	731071	1	HOSE, 4 STR - 4 STR MED (VALVE SG A TO SQU CYL R)
22	731072	1	HOSE, 4 STR - 4 45 MED (RH MB CASE TO SCRUB HEAD TEE)
23	731073	1	HOSE, 4 STR - 4 90 MED (SCRUB HD TO IMP CASE)
24	731074	1	HOSE, 4 STR - 4 90 MED (IMP CASE TO RES)
25	731075	1	HOSE, 4 STR - 4 90 MED (SSB VALVE T1 TO RES)
26	731076	1	HOSE, 4 STR - 4 45 MED (WHEEL DRIVE CASE TO RES)
27	731077	1	HOSE, 8 STR - 8 45 SPCL (VDP L TO WHEEL DRIVE R)
28	731078	1	HOSE, 8 STR - 8 45 SPCL (VDP R TO WHEEL DRIVE F)
29	731081	1	HOSE, 10 STR - 8 45 MED (VALVE T2 TO SSB VALVE T2)
30	731082	1	HOSE, 8 STR - 8 90 MED (SSB VALVE SB OUT TO SB R)
31	731083	1	HOSE, 8-STR - 8 STR MED (SSB VALVE SB IN TO SB F)
32	731084	1	HOSE, 4-STR - 4 STR MED (STR TEE TO SSB VALVE P1)
33	731085	1	HOSE, 4 STR - 4 90 MED (VALVE T1 TO SSB VALVE T1)
34	731089	1	HOSE, 4 STR - 4 STR MED (SSB VALVE SBE A TO EXT CYL L)
35	731087	1	HOSE, 4 STR - 4 STR MED (SSB VALVE SBE B TO EXT CYL R)
36	731088	1	HOSE, 4 STR - 4 STR MED (SSB VALVE SBL A TO LIFT CYL U)
37	731089	1	HOSE, 4 STR - 4 STR MED (SSB VALVE SBL B TO LIFT CYL L)
38	731168	1	HOSE, 4 STR - 4 45 MED (LH MB CASE TO SCRUB HEAD TEE)

OPTION - SPRAY AND WASH GROUP (730040)

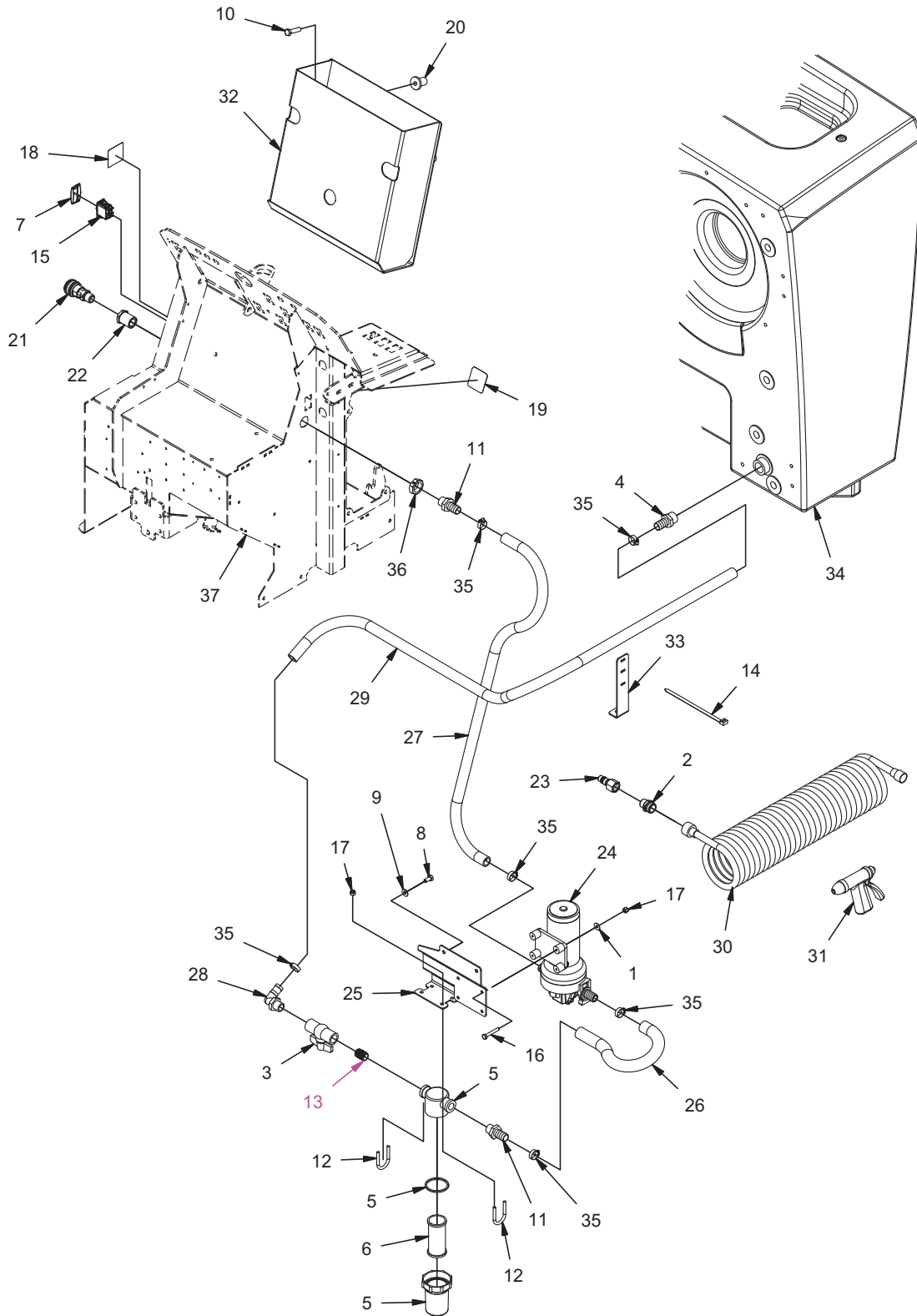

REV E

OPTION - SPRAY AND WASH GROUP (730040)

730040 PARTS LIST			
ITEM	QTY	PART NUMBER	DESCRIPTION
1	4	12332011	WASHER, FENDER, M6
2	1	281426	FITTING, MALE GARDEN HOSE
3	1	320997	BALL VALVE, INLINE, 1/2 NPT
4	1	3303388	FITTING, 3/4 BARB TO 3/4 NPT, BRASS
5	1	3323501	FILTER ASSEMBLY
6	1	3332264	FILTER ELEMENT - SERVICE
7	1	3342273	SWITCH COVER - BLACK, CLEAR LENS
8	2	3400291	BOLT, M8-1.25 X 16 HH
9	2	3400384	WASHER, 5/16 BELLEVILLE
10	3	3400455	SCREW, 3/8-16 X 1.50 HH SS
11	2	3320728	FITTING, 1/2 MPT - 3/4 NB, BRASS
12	2	3401981	CLAMP
13	1	383465	FTG-NIPPLE 1/2 MPT X 1-1/8 LG BRASS
14	1	620037	NYLON CABLE TIE
15	1	620137	SWITCH BODY, DPST W/GREEN LAMP
16	4	3400173	SCREW, 1/4-20 X 1.75 HH ZP
17	8	712667	NUT-NYLOC 1/4-20 SS
18	1	715969	DECAL, WASH SYSTEM
19	1	715970	DECAL, WASH SWITCH
20	3	730991	NUT, RUBBER EXPANSION
21	1	731043	COUPLER, QUICK DISCONNECT
22	1	731044	FITTING, BULKHEAD COUPLING
23	1	731048	FITTING, QUICK DISCONNECT NIPPLE
24	1	731365	PUMP, SOLUTION
25	1	731367	BRACKET, PUMP MNT
26	1	731371	TUBING, .75 ID X 15.00 REINFORCED PVC
27	1	731372	TUBING, .75 ID X 80.00, VINYL
28	1	3315536	FITTING, ELBOW 1/2 MPT TO 3/4 HOSE BARB
29	1	731379	TUBING, .75 ID X XX.XX VINYL
30	1	731383	HOSE, COIL, .38 ID X 50 FT
31	1	731384	NOZZLE, SPRAY
32	1	731615	WELDMENT, HOSE CARRIER
33	1	731460	BRACKET, CLAMP
34	1	731463	TANK, SOLUTION, PRESS WASHER
35	6	3300535	CLAMP, HOSE
36	1	PART OF 731044	NUT
37	-	REF	CONSOLE

OPTION - PRESSURE WASHER PUMP GROUP (730041-1)

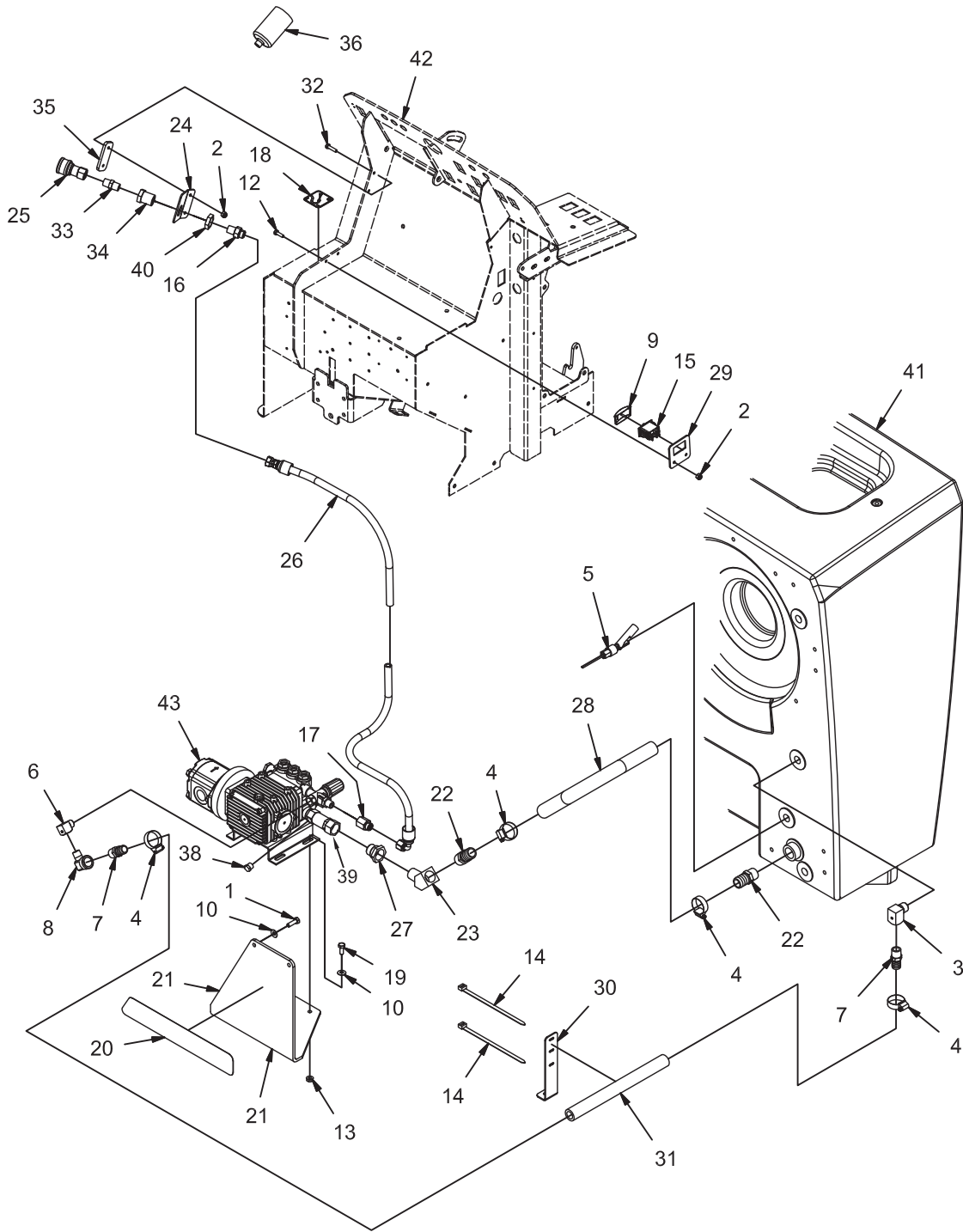

REV G

OPTION - PRESSURE WASHER PUMP GROUP (730041-1)

Parts List 730041-1			
ITEM	PART NUMBER	QTY	DESCRIPTION
1	11039567	2	BOLT, M8-125 X 25 HH SS
2	12040044	4	NUT, M6-1.00 ESN
3	281093	1	FTG, BRASS ELBOW, 1/2 MPT - 1/2 FPT
4	3302193	4	CLAMP, HOSE, .75 - 1.25
5	3302737-1	1	SWITCH, FLOAT
6	3320551	1	FTG, BRASS ELBOW, 3/8 MPT - 3/8 FPT
7	3320728	2	FTG, STR, 1/2 MPT 3/4 HOSE BARB
8	3339916	1	FTG, BRASS ELBOW, .38 FPT TO .50 MPT
9	3342273	1	SWITCH COVER - BLACK, CLEAR LENS
10	3400384	6	WASHER, 5/16 BELLEVILLE
11	3500118	1	EDGING, VINYL TRIM .125 X 12.00
12	600913	2	BOLT, M6-100 X 20 HH SS
13	600934	4	NUT, M8-1.25 FLNG
14	620037	2	NYLON CABLE TIE
15	620137	1	SWITCH BODY, DPST W/GREEN LAMP
16	675634	1	FITTING, STR, -6 MPT - 6 OFS SS
17	675635	1	FITTING, STR, -6 FPT - 6 OFS SS
18	715970	1	DECAL, WASH SWITCH
19	717030	4	BOLT, M8-1.25 X 20 HH SS
20	730967	1	PAD, STEP
21	731422	1	MOUNT, PRESSURE WASHER
22	731423	2	FTG, STR, 3/4 MPT 1 HOSE BARB
23	731424	1	FTG, BRASS, 45 STREET ELBOW, 3/4 NPT
24	731436	1	MOUNT, QUICK DISCONNECT
25	731441	1	QUICK DISCONNECT COUPLER W/ VALVING
26	731454	1	HOSE, -6 STR -6 90, SS END FITTINGS
27	731455	1	ADAPTER, BRASS MALE HOSE TO 3/4 FPT
28	731456	1	TUBING, 1.00 ID RENFORCED VINYL
29	731459	1	BRACKET, SWITCH
30	731460	1	BRACKET, CLAMP
31	731461	1	TUBING, .75 ID VINYL
32	731555	2	SCR-HH M6-1.00 X 25 HH SS
33	731618	1	FTG, HEX NIPPLE, 3/8 NPT SS
34	731619	1	ANCHOR COUPLING 3/8 NPT SS
35	731651	1	PLT, SPACER
36	747041	1	BOOT, IGNITION SWITCH
37	748735	1	HARNESS ASSY, PRESSURE WASHER
38	829619	1	PLUG, 1/4 MPT, BRASS
39	731035	1	FILTER, PRESSURE WASHER, NAUTILUS
40	PART OF 731619	1	NUT
41	REF	-	TANK, SOLUTION
42	REF.	-	CONSOLE
43	REF.	-	PRESSURE WASHER

**ORDER 731486 CHECK VALVE REPLACEMENT KIT FOR 731421 PRESSURE WASHER ASSEMBLY

OPTION - PRESSURE WASHER HOSE AND WAND GROUP (730041-2)

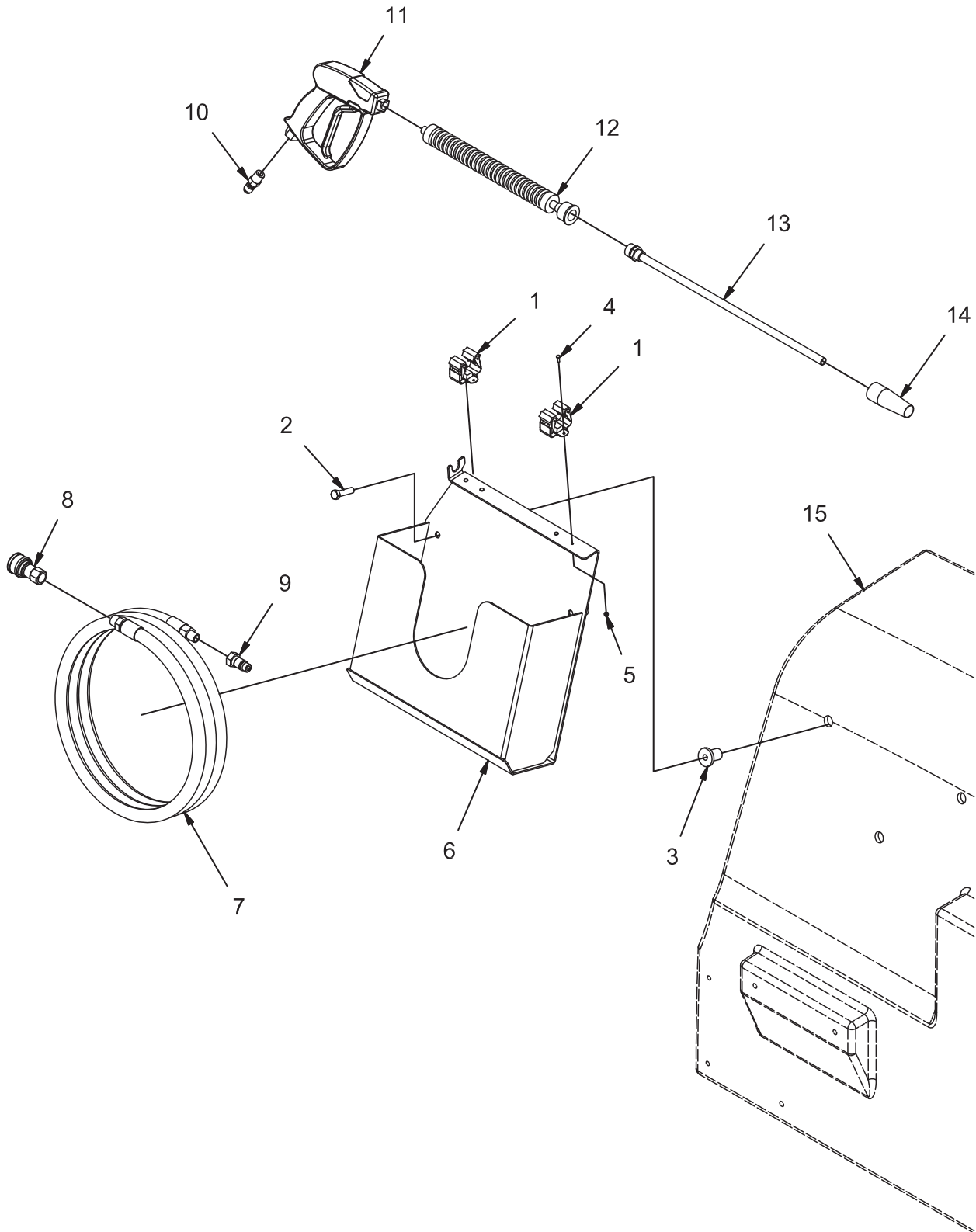

REV A

OPTION - PRESSURE WASHER HOSE AND WAND GROUP (730041-2)

Parts List 730041-2			
ITEM	PART NUMBER	QTY	DESCRIPTION
1	00560010	2	CLAMP
2	3400455	3	SCREW, 3/8-16 X 1.50 HH SS
3	730991	3	NUT, RUBBER EXPANSION
4	710204	4	SCR-PHMS 6-32 X .50 ZP
5	711371	4	NUT-NYLOC 6-32 ZP
6	731437	1	WELDMENT, HOSE BOX
7	731440	1	HOSE, PRESSURE WASHER 50 FT (PART OF KIT 731457)
8	731441	1	QUICK DISCONNECT, COUPLER (PART OF KIT 731457)
9	731442	1	QUICK DISCONNECT, HP, NIPPLE, SS
10	731443	1	QUICK DISCONNECT PLUG, 6MPT (PART OF KIT 731457)
11	731444	1	TRIGGER GUN (PART OF KIT 731457)
12	731445	1	INSULATED LANCE (PART OF KIT 731457)
13	731446	1	LANCE (PART OF KIT 731457)
14	731447	1	ADJUSTABLE TIP (PART OF KIT 731457)
15	REF.	-	SOLUTION TANK

OPTION - PRESSURE WASHER HYDRAULIC HOSE GROUP (730041-3)

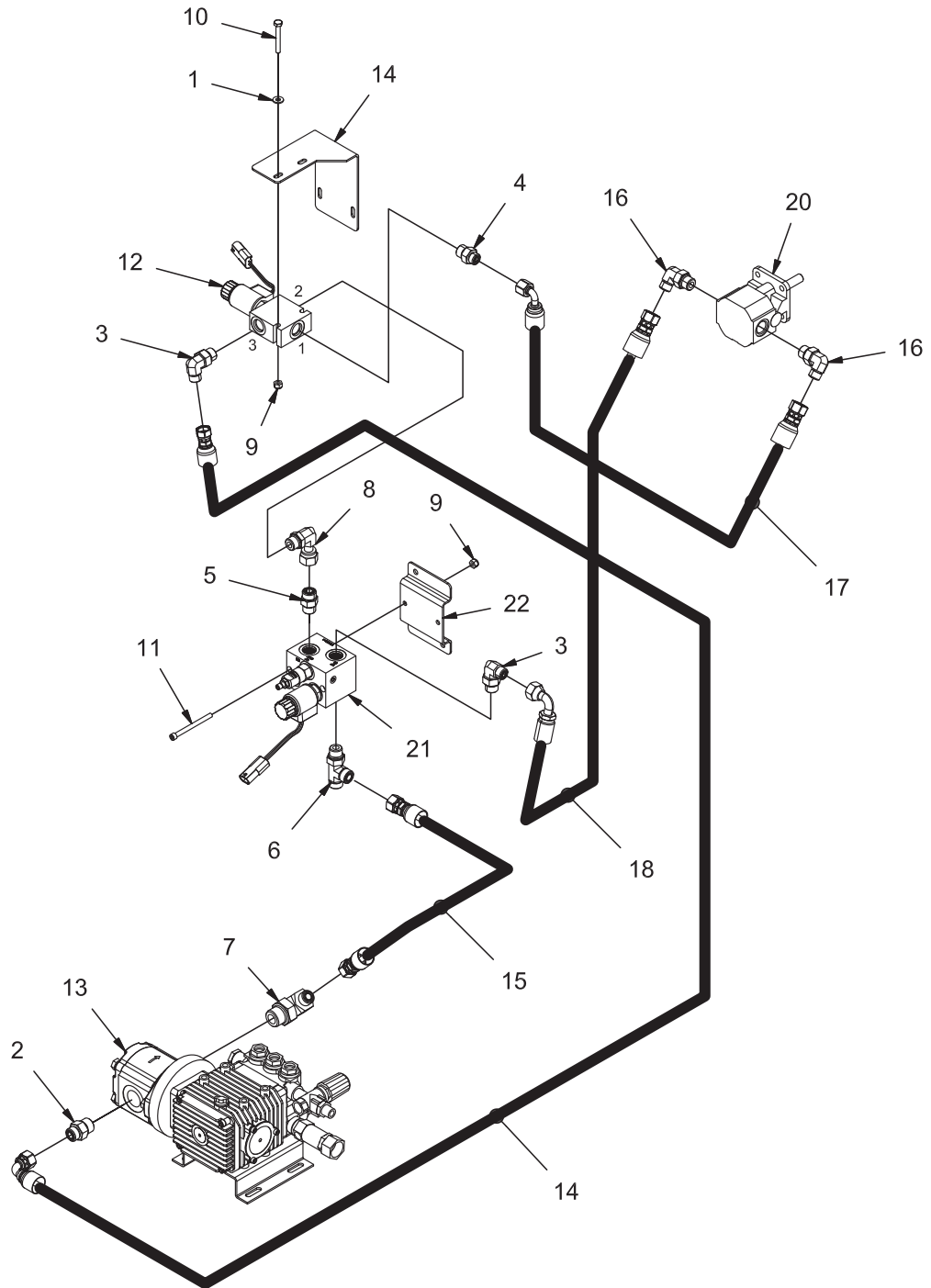

REV C

OPTION - PRESSURE WASHER HYDRAULIC HOSE GROUP (730041-3))

Parts List 730041-3			
ITEM	PART NUMBER	QTY	DESCRIPTION
1	3400089	2	WASHER, 1/4 .625 X .281 X .063
2	3400689	1	FTG, STR THD CONNECTOR -8 ORFS TO -10 SAE
3	675520	1	FITTING, ELBOW, 6 ORFS - 8 O-RING
4	675521	1	FITTING, STR, -6 ORFS - 8 SAE
5	675524	1	FITTING, STR, -8 ORFS - 8 SAE
6	675525	1	FITTING, RUN TEE, -8 ORFS - 8 ORFS - 8 SAE
7	675537	1	FITTING, 90, -8 ORFS - 12 SAE
8	675628	1	FTG - STR THD SWIVEL ELBOW, -8 ORFS TO -8 SAE
9	711373	4	NUT, FIBER INSERT 1/4-20
10	712567	2	SCREW, 1/4-20 X 2.00 HH SS
11	730965	2	BOLT, 1/4-20 X 3.00 SOC HD CAP
12	731292	1	ASSEMBLY, SOLENOID VALVE 2-POS 3-WAY
12A	731298	1	CARTRIDGE VALVE - SERVICE PART
12B	731299	1	VALVE BLOCK - SERVICE PART
12C	731300	1	COIL - SERVICE PART
13	731421	1	ASSEMBLY, PRESSURE WASHER (PART OF KIT 731457)
13A	731414	-	MOTOR, PRESSURE WASHER
13B	731421	-	PUMP, PRESSURE WASHER
13C	731413	-	MOTOR/PUMP, PRESSURE WASHER SUB ASSEMBLY
14	731431	1	BRACKET, SOLENOID MNT
15	731452	1	HOSE, 6 STR - 8 90 (SOL 3 TO PW PUMP IN)
16	731453	1	HOSE, 8 STR - 8 STR (PW PUMP OUT TO IMP SOL T)
17	REF.	-	FITTING, -6ORFS TO -8 SAE
18	REF.	-	HOSE 731061-1 (IMP LEFT TO SOL 1)
19	REF.	-	HOSE 731062-1 (IMP RIGHT TO IMP SOL VF IN)
20	REF.	-	IMPELLER MOTOR
21	REF.	-	IMPELLER MANIFOLD
22	REF.	-	MANIFOLD BRACKET

OPTION - LOW LP INDICATOR GROUP (730042)

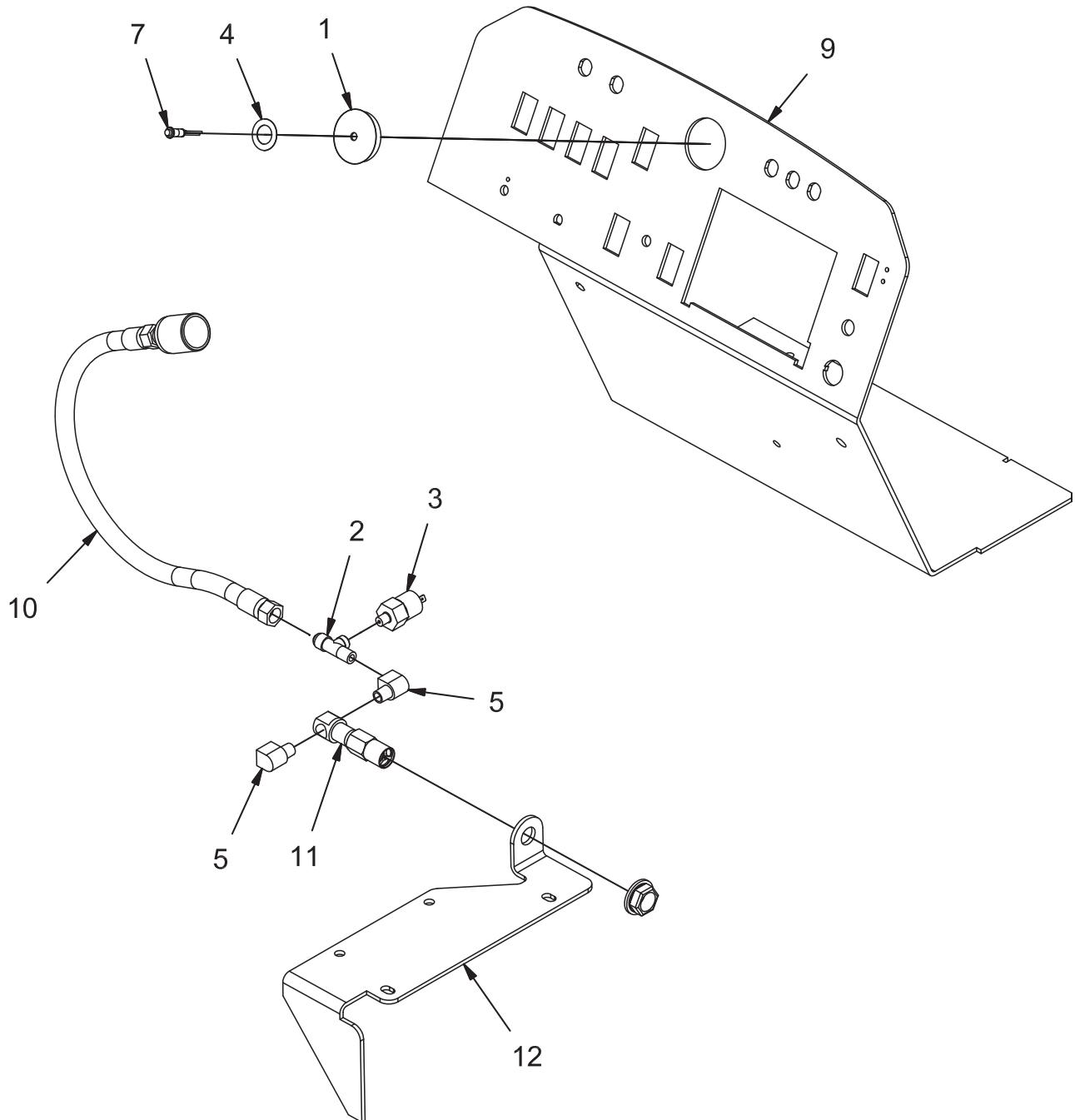

REV C

OPTION - LOW LP INDICATOR GROUP (730042)

Parts List 730042			
ITEM	PART NUMBER	QTY	DESCRIPTION
1	3301822-1	1	PLUG, PLASTIC, W/ MOUTING HOLE
2	3305535-2	1	TEE, BRASS
3	3305535-3	1	LP INDICATOR SENSOR
4	3305535-4	1	LPG LABEL
5	620238	2	FITTING, 1/4 NPT STREET ELBOW, BRASS
6	748770	1	WIRE ASSY, LOW LP INDICATOR
7	748960	1	ASSY, INDICATOR LAMP, LO LP
8	746050	2	INSULATOR CAP, TERMINAL (NOT SHOWN)
9	REF.	-	INSTRUMENT PANEL
10	REF.	-	LP TANK HOSE
11	REF.	-	RELIEF VALVE MOUNT
12	REF.	-	FRAME WITH PRESSURE RELIEF VALVE

OPTION - SIDE BROOM WATER MIST GROUP (730043)

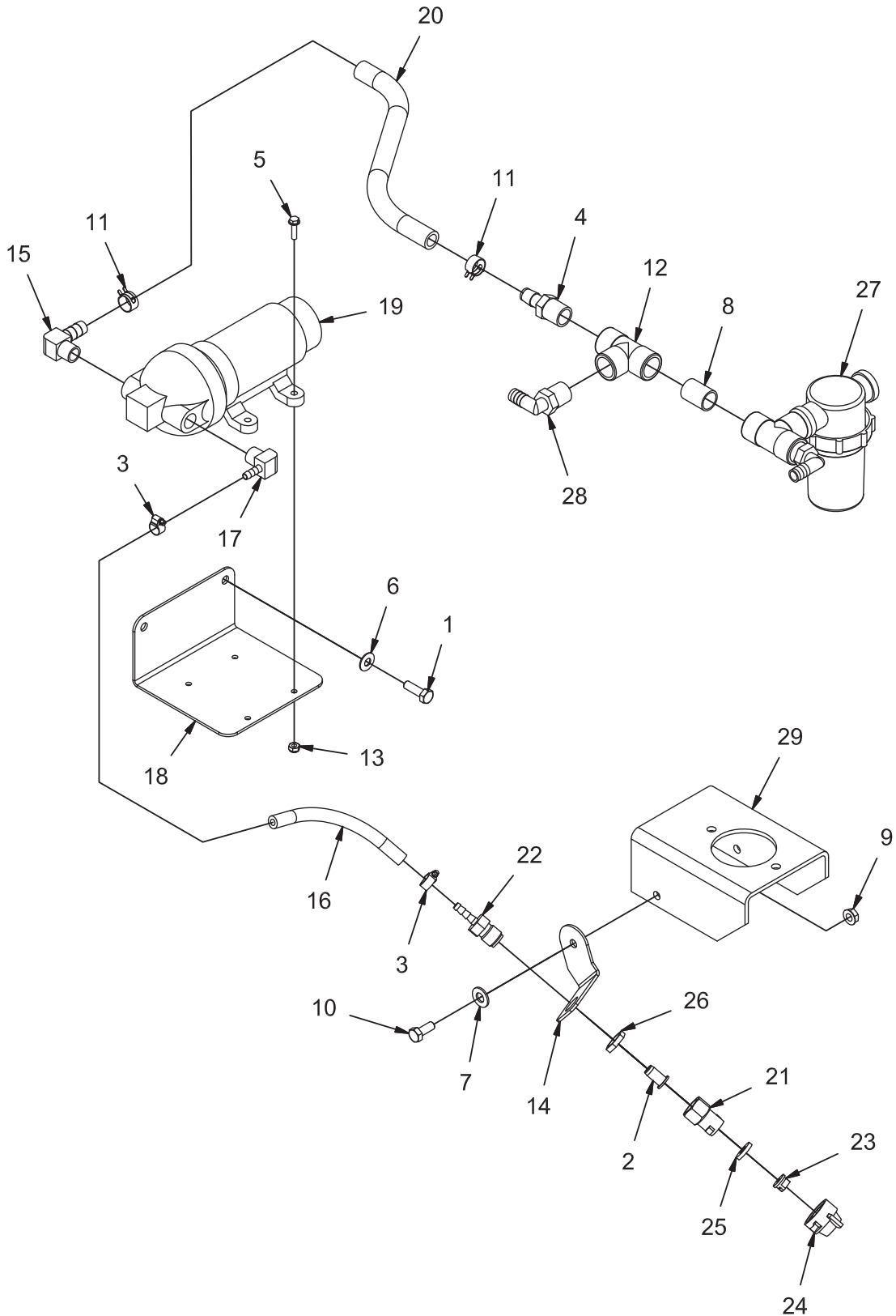

REV B

OPTION - SIDE BROOM WATER MIST GROUP (730043)

Parts List 730043			
ITEM	PART NUMBER	QTY	DESCRIPTION
1	11039567	2	BOLT, M8-1.25 X 25 HH SS
2	281041	1	VALVE - CHECK
3	3302338	2	CLAMP, HOSE, .50
4	3315534	1	FITTING, PLASTIC, STR, .50 NPT .50 BARB
5	3400044	4	SCR-HEX, #10-32 X .75 ZP
6	3400384	2	WASHER, 5/16 BELLEVILLE
7	3400385	1	WASHER, 3/8, BELLEVILLE
8	383465	1	1/2 NPT CLOSE PIPE NIPPLE, BRASS
9	600934	1	NUT, M8-1.25 FLNG
10	717030	1	BOLT, M8-1.25 X 20 HH SS
11	730962	2	CLAMP, WIRE HOSE
12	730966	1	FITTING, PVC TEE, FEMALE 1/2 NPT
13	731242	4	NUT, 10-32 ESN SS
14	731538	1	MOUNT, NOZZLE
15	731558	1	FTG, ELBOW, 3/8 NPT TO 1/2 BARB, BRASS
16	770669	1	TUBING, .25 ID
17	731603	1	FTG, ELBOW, 3/8 NPT TO 1/4 BARB, BRASS
18	770648	1	BRACKET, PUMP MNT
19	770653-1	1	PUMP, SOLUTION, 2 GPM, 12 VDC
20	770662	1	TUBING, 1/2 ID REINFORCED VINYL
21	770666	1	ADAPTER, SPRAY
22	770667	1	FITTING, SPECIAL
23	770668	1	SPRAY TIP - 11001
24	833141	1	CAP
25	833142	1	GASKET - CAP
26	PART OF 770667	1	NUT
27	REF.	-	EXISTING COMPONENTS
28	REF.	-	EXISTING COMPONENT
29	REF.	-	FRAME

OPTION - REAR SQUEEGEE GUARD (730048)

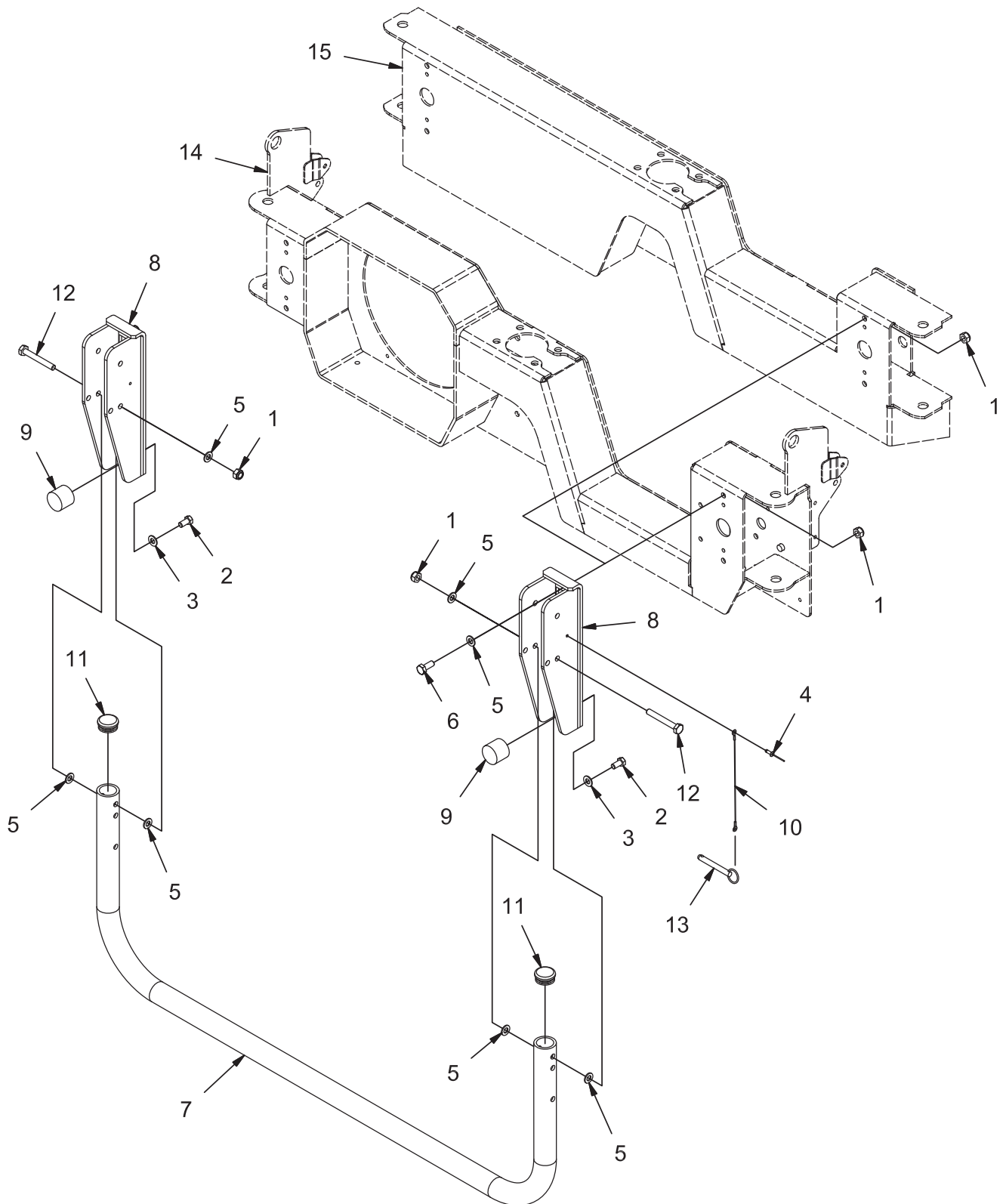

REV A

OPTION - REAR SQUEEGEE GUARD (730048)

Parts List 730048			
ITEM	PART NUMBER	QTY	DESCRIPTION
1	12040069	6	NUT, M10-1.50 ESN
2	3400335	2	SCREW, 3/8-16 X .750 HH SS
3	3400385	2	WASHER, 3/8, BELLEVILLE
4	3400484	1	RIVET, MULTI-GRIP
5	730344	10	WASHER, M10 SS
6	730958	4	BOLT, M10-1.50 X 25 HH SS
7	731488	1	TUBE, GUARD
8	731491	2	WELDMENT, GUARD MOUNT
9	731492	2	BUMPER, URETHANE
10	731501	1	LANYARD
11	731502	2	PLUG, HOLE, 1.25
12	731462	2	SCR-HH, M10-1.50 X 75 HH P CLASS 8.8
13	731493	1	PIN, CLEVIS, .375, BALL DETENT
14	REF.	-	REAR BUMPER - HAND DUMP
15	REF.	-	REAR BUMPER - HIGH DUMP

OPTION - PVC FREE COMPONENTS (730049)

LOWER SQUEEGEE HOSE 730985-1 TO BE USED IN PLACE OF 730985 IN SQUEEGEE GROUP 730118

UPPER SQUEEGEE HOSE 730984-1 TO BE USED IN PLACE OF 730984 IN RECOVERY TANK GROUP 730122

RECOVERY TANK DRAIN HOSE 731533-1 TO BE USED IN PLACE OF 731533 IN RECOVERY TANK DRAIN GROUP 730179

SOLUTION TANK DRAIN HOSE 730987-1 TO BE USED IN PLACE OF 730987 IN SOLUTION TANK GROUP 730121

HOSE 730970-1 TO BE USED IN PLACE OF 730970 IN SOLUTION CONTROL GROUP 730123

HOSE 730971-1 TO BE USED IN PLACE OF 730971 IN SOLUTION CONTROL GROUP 730123

HOSE 730972-1 TO BE USED IN PLACE OF 730972 IN SOLUTION CONTROL GROUP 730123

HOSE 730973-1 TO BE USED IN PLACE OF 730973 IN SOLUTION CONTROL GROUP 730123

STAINLESS STEEL SOLUTION DELIVERY BAR 731523 TO BE USED IN PLACE OF 731389 IN SOLUTION CONTROL GROUP 730117

PLUG BOTH ENDS OF SOLUTION DELIVERY BAR 731523 WITH PLUG 3400194 (BRASS 3/8 NPT PIPE PLUG - 2 REQUIRED)

REV A

OPTION - TIE DOWNS (730026)

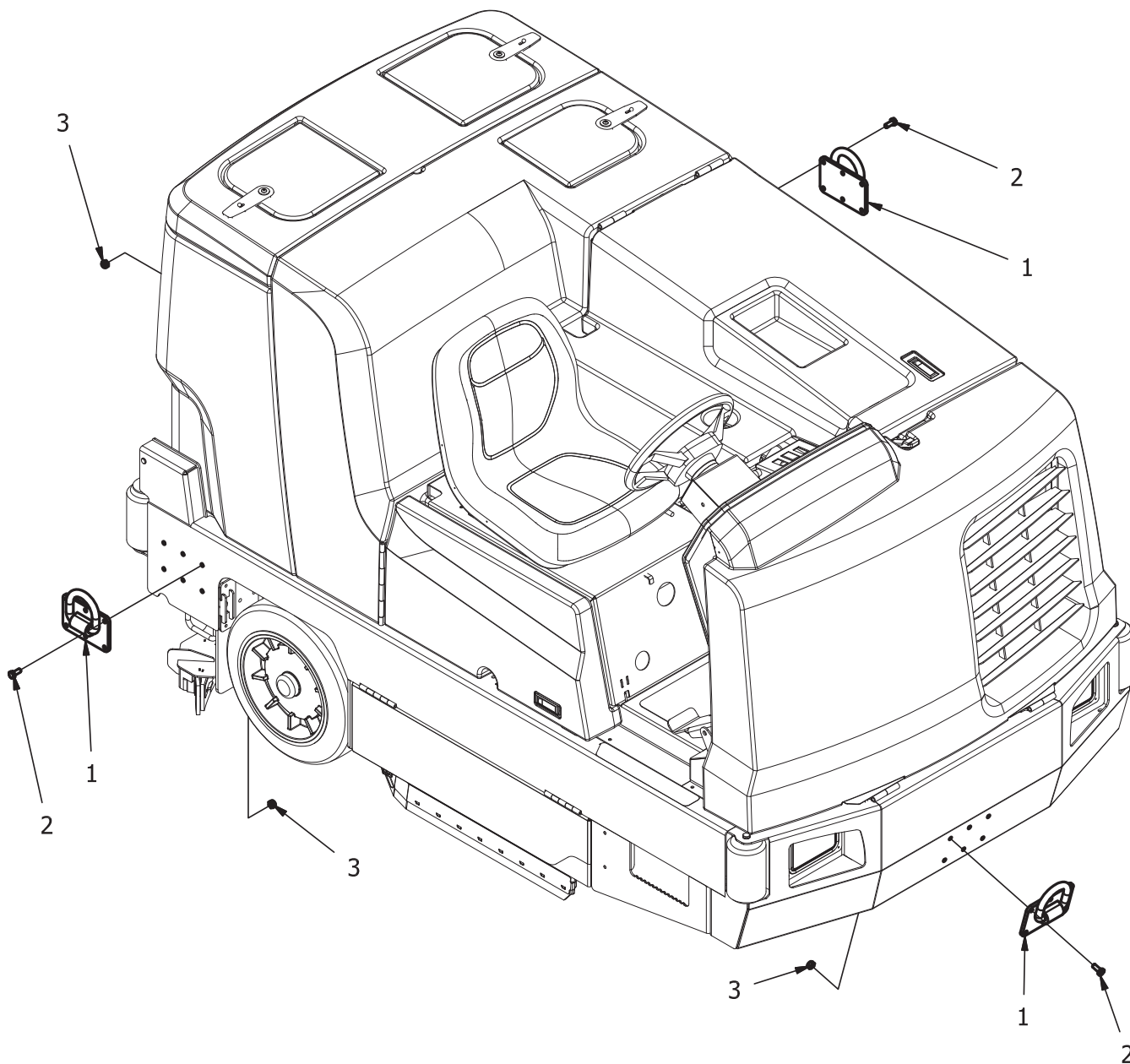

PARTS LIST - 730026			
ITEM	QTY	PART NUMBER	DESCRIPTION
1	3	731566	WELDMENT, D-RING
2	18	11038346	BOLT, M10-1.50 X 25 HH
3	18	12040069	NUT, M10-1.50 ESN

REV A

OPTION - FRONT WHEEL FENDER (730052)

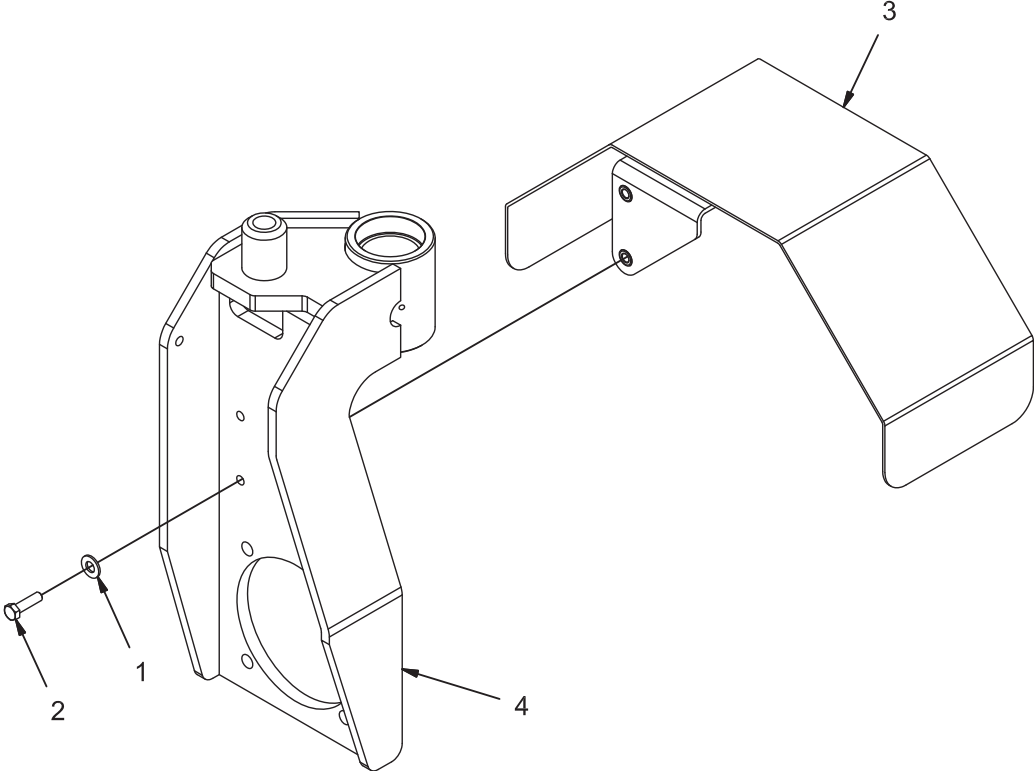

REV A

OPTION - FRONT WHEEL FENDER (730052)

Parts List 730052			
ITEM	PART NUMBER	QTY	DESCRIPTION
1	3400385	2	WASHER, 3/8, BELLEVILLE
2	730506	2	BOLT, M8-125 X 30 HH SS
3	731301-1	1	ASSEMBLY, FENDER
4	REF.	-	STEERING FORK

OPTION - DRY SWEEP - PUMP (730053-1)

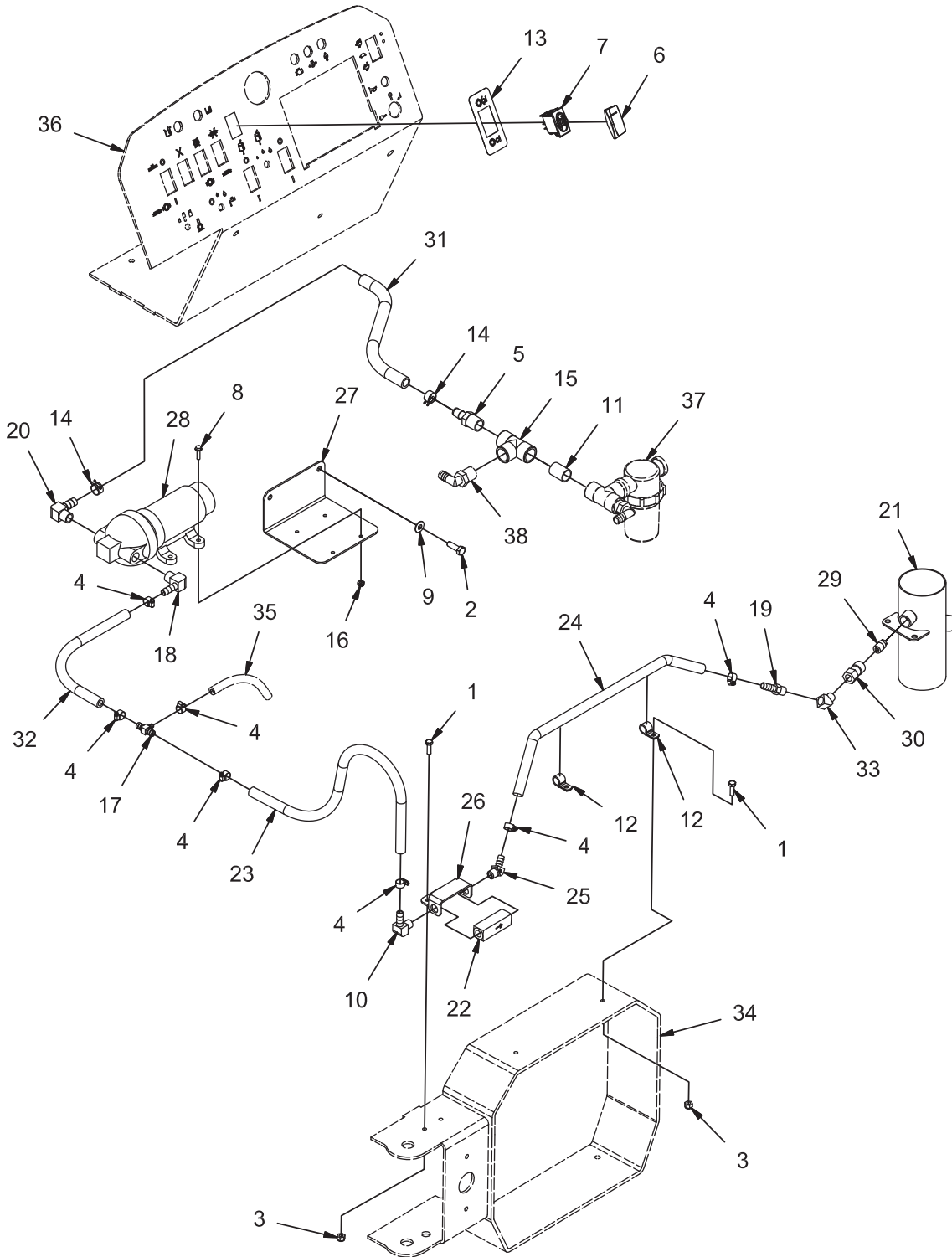

REV A

OPTION - DRY SWEEP - PUMP (730053-1)

Parts List 730053-1			
ITEM	PART NUMBER	QTY	DESCRIPTION
1	11038098	4	BOLT, M6-100 X 20 HH
2	11039567	2	BOLT, M8-125 X 25 HH SS
3	12040044	4	NUT, M6-1.00 ESN
4	3302338	7	CLAMP, HOSE, .50
5	3315534	1	FITTING, PLASTIC, STR, .50 NPT .50 BARB
6	3342273	1	SWITCH COVER - BLACK, CLEAR LENS
7	3342705	1	SWITCH, DPST
8	3400044	4	SCR-HEX, #10-32 X .75 ZP
9	3400384	2	WASHER, 5/16 BELLEVILLE
10	3400793	1	FTG- ELBOW, 1/4 NPT TO 3/8 BARB, BRASS
11	383465	1	1/2 NPT CLOSE PIPE NIPPLE, BRASS
12	713527	2	P-CLAMP, VINYL COVERED, 1/2 DIA
13	715979	1	DECAL, DRY SWEEP
14	730962	2	CLAMP, WIRE HOSE
15	730966	1	FITTING, PVC TEE, FEMALE 1/2 NPT
16	731242	4	NUT, 10-32 ESN SS
17	731381	1	UNION TEE, 3/8 TO 1/4, BRASS
18	731556	1	FTG, ELBOW, 3/8 NPT TO 3/8 BARB, BRASS
19	342435	1	FTG, STR, 1/4 NPT TO 3/8 HOSE BARB, BRASS
20	731558	1	FTG, ELBOW, 3/8 NPT TO 1/2 BARB, BRASS
21	731563	1	WELDMENT, SQU TUBE, DS
22	731584	1	CHECK VALVE, BRASS
23	731900	1	TUBING, 3/8 ID, REINFORCED VINYL
24	731901	1	TUBING, 3/8 ID, REINFORCED VINYL
25	731902	1	FTG - 45 1/4 MPT TO 3/8 HOSE BARB BRASS
26	731903	1	MOUNT, CHECK VALVE
27	770648	1	BRACKET, PUMP MNT
28	770653	1	PUMP, SOLUTION, 2 GPM, 12 VDC
29	770654	1	NOZZLE, 120 DEGREE
30	770661	1	SOCKET, SPRAY NOZZLE
31	770662	1	TUBING, 1/2 ID REINFORCED VINYL
32	770663	1	TUBING, 3/8 ID REINFORCED VINYL
33	833906	1	FTG-ADAPTER, 1/4 MPT TO 1/4 FPT BRASS
34	REF.	-	REAR BUMPER
35	REF.	-	TUBING TO SPRAYER
36	REF.	-	CONSOLE
37	REF.	-	FILTER ASSEMBLY
38	REF.	-	FITTING, PLASTIC, 90, PART OF SOL CONT GROUP

**GROUP (730053) - OPTION DRY SWEEP, INCLUDES SUB-GROUPS:
730053-1, 730053-2, 730053-3, 730053-4**

OPTION - DRY SWEEP - SKIRT (730053-2)

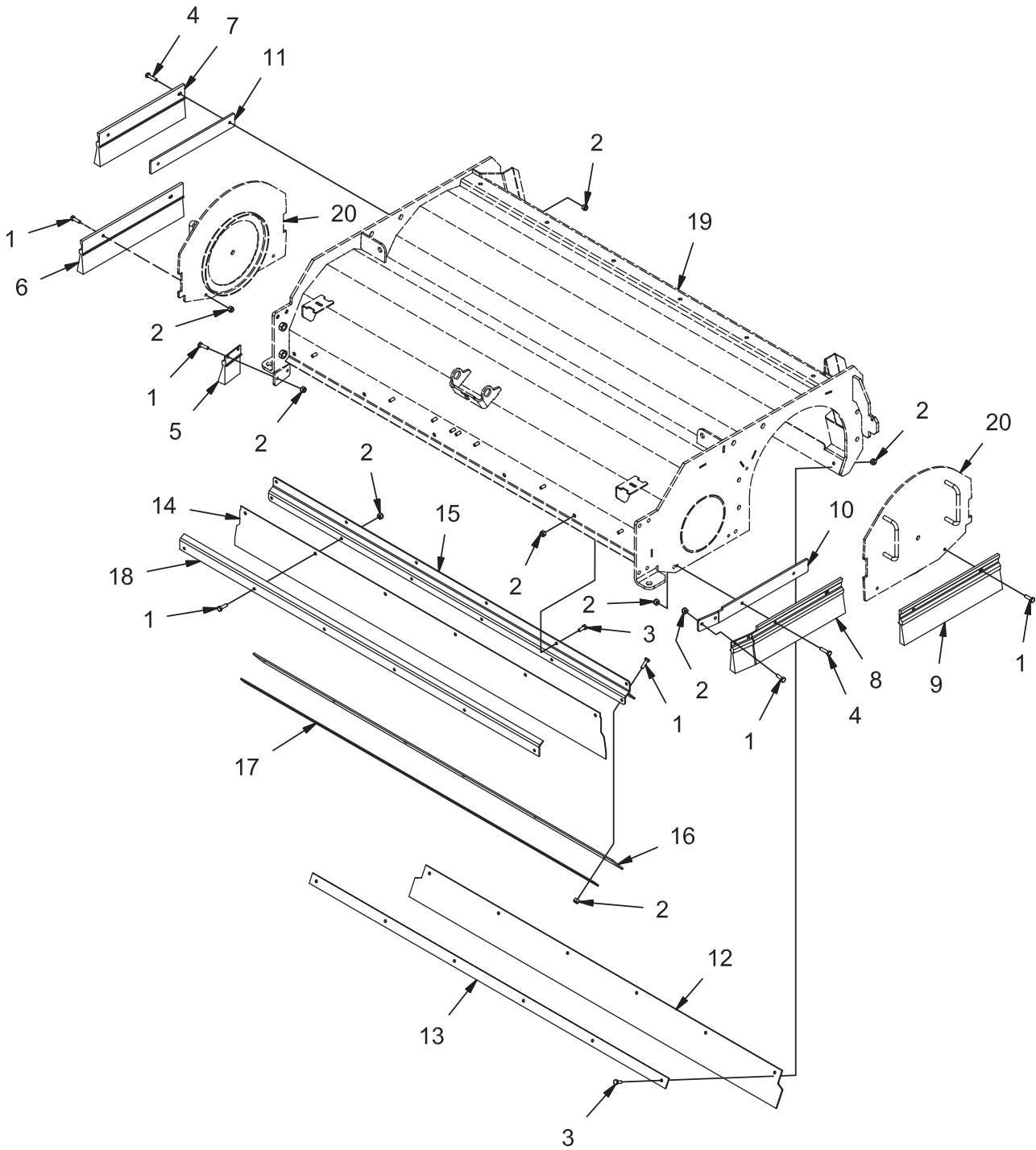

REV A

OPTION - DRY SWEEP - SKIRT (730053-2)

Parts List 730053-4			
ITEM	PART NUMBER	QTY	DESCRIPTION
1	600913	20	BOLT, M6-100 X 20 HH SS
2	600933	36	NUT, M6-1.00 ESN SS
3	730934	12	BOLT, M6-1.00 X 16 HH SS
4	731555	4	SCR-HH M6-1.00 X 25 HH SS
5	770606	1	SKIRT, DC, RH TIP
6	770607	1	SKIRT, DC, RH FRONT
7	770608	1	SKIRT, DC, RH REAR
8	770609	1	SKIRT, 26 IN
9	770610	1	SKIRT, DC, LH REAR
10	770611	1	BAR, SPACER, LH FRONT
11	770612	1	BAR, SPACER, RH REAR
12	770614	1	SKIRT, DC, REAR
13	770615	1	STRAP, REAR SKIRT RETAINER
14	770656	1	SKIRT, DC, FRONT
15	770657	1	WELDMENT, FRONT SKIRT MNT
16	770659	1	SKIRT, FRONT RECERC
17	770660	1	STRAP, RETAINER
18	770664	1	ANGLE, RETAINER
19	REF.	-	SCRUB HEAD
20	REF.	-	BRUSH RETAINER

**GROUP (730053) - OPTION DRY SWEEP, INCLUDES SUB-GROUPS:
730053-1, 730053-2, 730053-3, 730053-4**

OPTION - DRY SWEEP - RADIATOR GRILLE (730053-3)

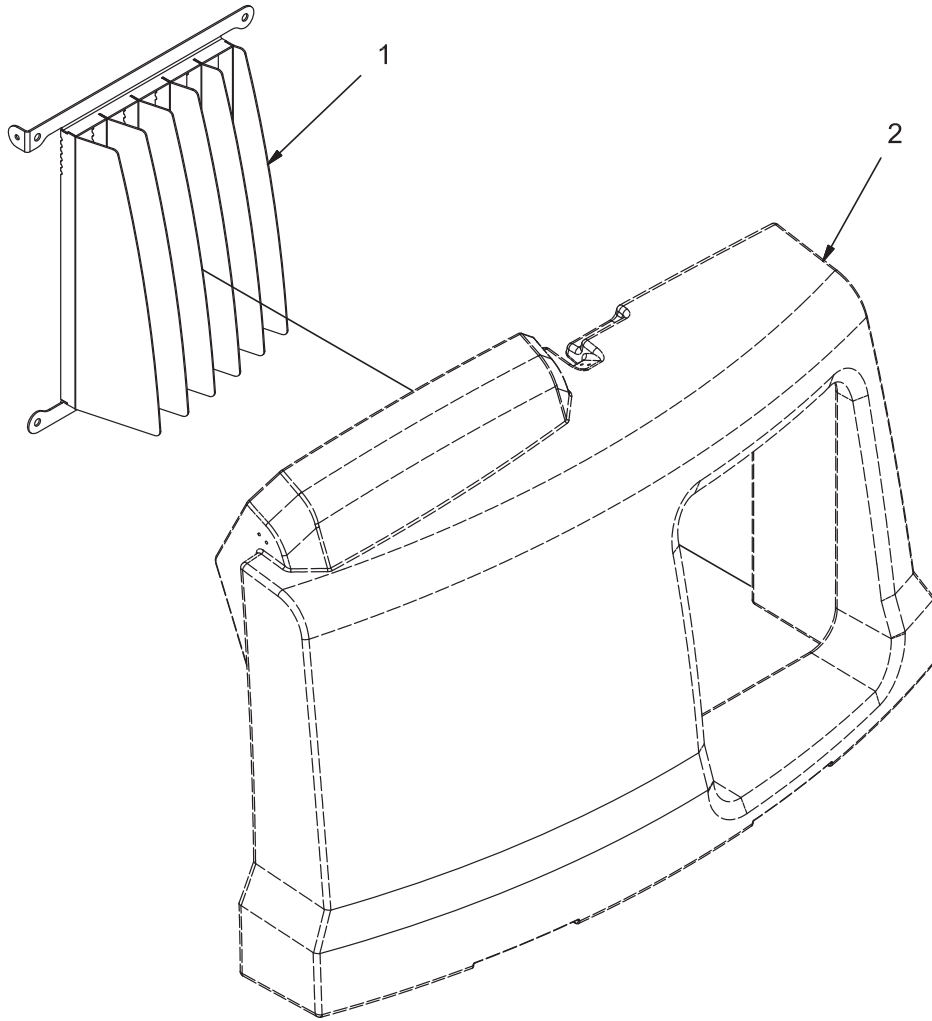

REV A

OPTION - DRY SWEEP - RADIATOR GRILLE (730053-3)

Parts List 730053-3			
ITEM	PART NUMBER	QTY	DESCRIPTION
1	731570	1	WELDMENT, GRILLE
2	REF.	-	FRONT COVER

**GROUP (730053) - OPTION DRY SWEEP, INCLUDES SUB-GROUPS:
730053-1, 730053-2, 730053-3, 730053-4**

OPTION - DRY SWEEP - WATER MIST (730053-4)

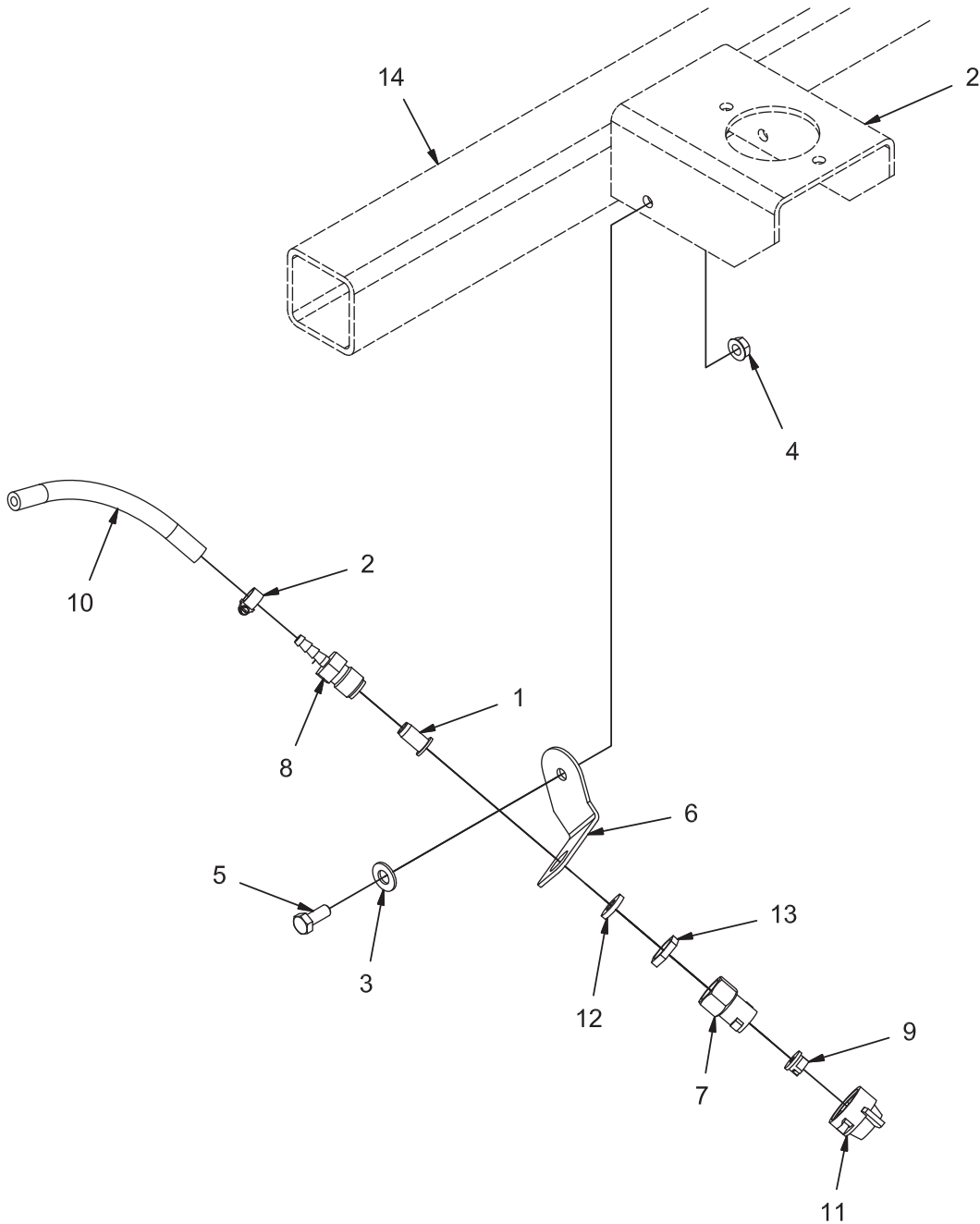

REV A

OPTION - DRY SWEEP - WATER MIST (730053-4)

Parts List 730053-4			
ITEM	PART NUMBER	QTY	DESCRIPTION
1	281041	1	VALVE - CHECK
2	3302338	1	CLAMP, HOSE, .50
3	3400385	1	WASHER, 3/8, BELLEVILLE
4	600934	1	NUT, M8-1.25 FLNG
5	717030	1	BOLT, M8-1.25 X 20 HH SS
6	731538	1	MOUNT, NOZZLE
7	770666	1	ADAPTER, SPRAY
8	770667	1	FITTING, SPECIAL
9	770668	1	SPRAY TIP - 11001
10	770669	1	TUBING, .25 ID
11	833141	1	CAP
12	833142	1	GASKET - CAP
13	PART OF 770667	1	NUT, 11/16-16
14	REF.	-	FRAME

**GROUP (730053) - OPTION DRY SWEEP, INCLUDES SUB-GROUPS:
730053-1, 730053-2, 730053-3, 730053-4**

OPTION - HEATED SOL GROUP, COIL TYPE, LP (730057)

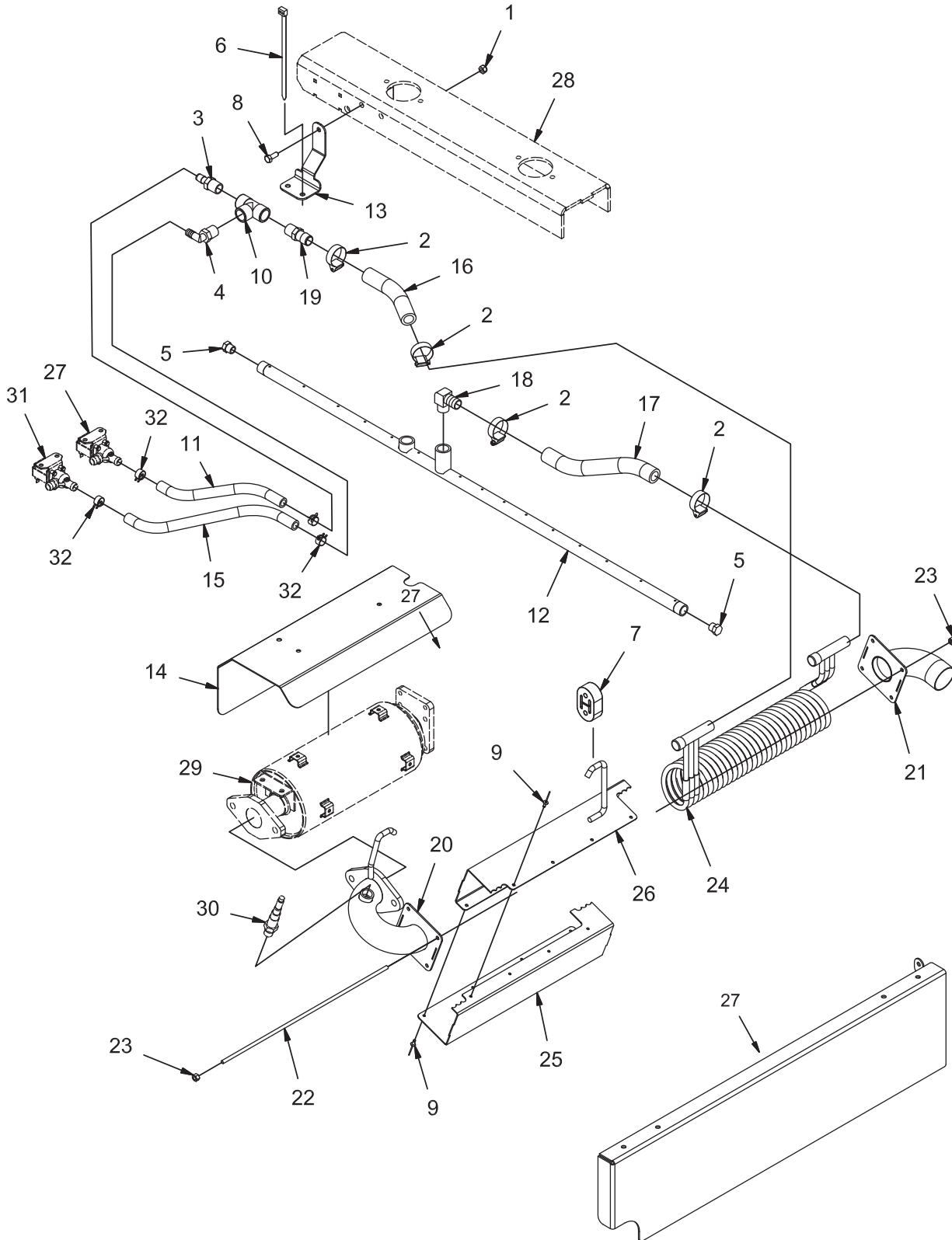

REV B

OPTION - HEATED SOL GROUP, COIL TYPE, DSL (730057)

Parts List			
ITEM	PART NUMBER	QTY	DESCRIPTION
1	12040259	1	NUT, M8-1.25 ESN SS
2	3300535	4	CLAMP - SCREW .5" to 1.25" DIA 201SS
3	3315534	1	FITTING, PLASTIC, STR, .50 NPT .50 BARB
4	3315535	1	FITTING, PLASTIC, 90, .50 NPT .50 BARB
5	3400194	2	PIPE PLUG, BRASS, 3/8
6	620037	3	NYLON CABLE TIE
7	620205	1	EXHAUST ISOLATOR
8	717030	1	BOLT, M8-1.25 X 20 HH SS
9	730654	8	RIVET,BLIND, .156 D X .062 - .125 GRIP SS
10	730966	1	FITTING, PVC TEE, FEMALE 1/2 NPT
11	730971	1	TUBING, .50 ID X 18.50 VINYL
12	731523	1	WELDMENT, SOLUTION DELIVERY TUBE, SS
13	731546	1	BRACKET, TEE MNT
14	731547	1	HEAT SHIELD, HEATED SOLUTION
15	731548	1	TUBING, .50 ID X 24.00 VINYL
16	731549	1	TUBING, 3/4 ID X 31.00 REINFORCED SILICON
17	731550	1	TUBING, 3/4 ID X 33.00 REINFORCED SILICON
18	731551	1	FTG, ELBOW, 1/2 NPT TO 3/4 BARB, BRASS
19	731554	1	FTG, STR, 1/2 NPT TO 3/4 BARB, PLASTIC
20	731657	1	WELDMENT, EXHAUST STUB
21	731658	1	WELDMENT, TAILPIPE
22	731664	4	ROD, TIE
23	731666	8	NUT, 1/4-20 HEX SS TOP LOCK
24	731669	1	WELDMENT, HEAT EXCHANGER
25	731670	1	CHANNEL, LH COVER
26	731672	1	WELDMENT, HE COVER
27	731640	1	WELDMENT, LH BRUSH DOOR HS
28	REF.	-	FRAME
29	REF.	-	CATALYTIC CONVERTER
30	REF.	-	O2 SENSOR
31	REF.	-	SOLUTION SOLENOID VALVES
32	REF.	-	WIRE HOSE CLAMPS

OPTION - HEATED SOL GROUP, COIL TYPE, DSL (730058)

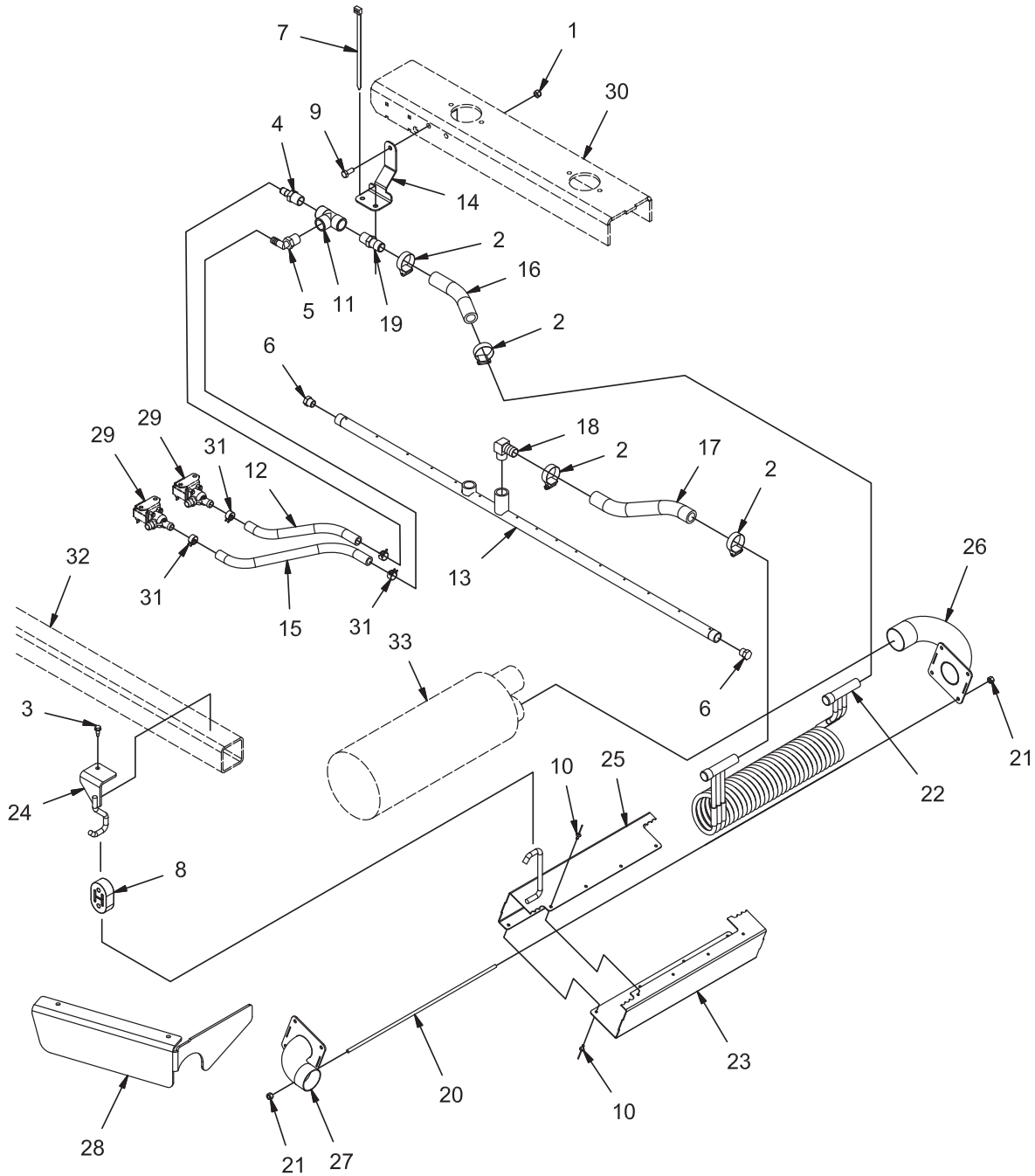

REV A

OPTION - HEATED SOL GROUP, COIL TYPE, DSL (730058)

Parts List			
ITEM	PART NUMBER	QTY	DESCRIPTION
1	12040259	1	NUT, M8-1.25 ESN SS
2	3302193	4	CLAMP, HOSE, .75 - 1.25
3	3311374	1	SCR-HH 1/4-14 X 3/4 SELF THREADING #3-P0I
4	3315534	1	FITTING, PLASTIC, STR, .50 NPT .50 BARB
5	3315535	1	FITTING, PLASTIC, 90, .50 NPT .50 BARB
6	3400194	2	PIPE PLUG, BRASS, 3/8
7	620037	3	NYLON CABLE TIE
8	620205	1	EXHAUST ISOLATOR
9	717030	1	BOLT, M8-1.25 X 20 HH SS
10	730654	8	RIVET, BLIND, .156 D X .062 - .125 GRIP SS
11	730966	1	FITTING, PVC TEE, FEMALE 1/2 NPT
12	730971	1	TUBING, .50 ID X 18.50 VINYL
13	731523	1	WELDMENT, SOLUTION DELIVERY TUBE, SS
14	731546	1	BRACKET, TEE MNT
15	731548	1	TUBING, .50 ID X 24.00 VINYL
16	731549	1	TUBING, 3/4 ID X 31.00 REINFORCED SILICON
17	731550	1	TUBING, 3/4 ID X 33.00 REINFORCED SILICON
18	731551	1	FTG, ELBOW, 1/2 NPT TO 3/4 BARB, BRASS
19	731554	1	FTG, STR, 1/2 NPT TO 3/4 BARB, PLASTIC
20	731664	4	ROD, TIE
21	731666	9	NUT, 1/4-20 HEX SS TOP LOCK
22	731669	1	WELDMENT, HEAT EXCHANGER
23	731670	1	CHANNEL, LH COVER
24	731673	1	WELDMENT, DIESEL HE HANGER
25	731676	1	WELDMENT, DIESEL HE COVER
26	731677	1	WELDMENT, DIESEL HE EXHAUST STUB
27	731679	1	WELDMENT, DIESEL HE TAILPIPE
28	731682	1	GUARD, DIESEL HE
29	REF.	-	SOLUTION SOLENOID VALVES
30	REF.	-	FRAME
31	REF.	-	WIRE HOSE CLAMPS
32	REF.	-	FRAME
33	REF.	-	MUFFLER

OPTION - RESERVE LPG TANK GROUP (730160)

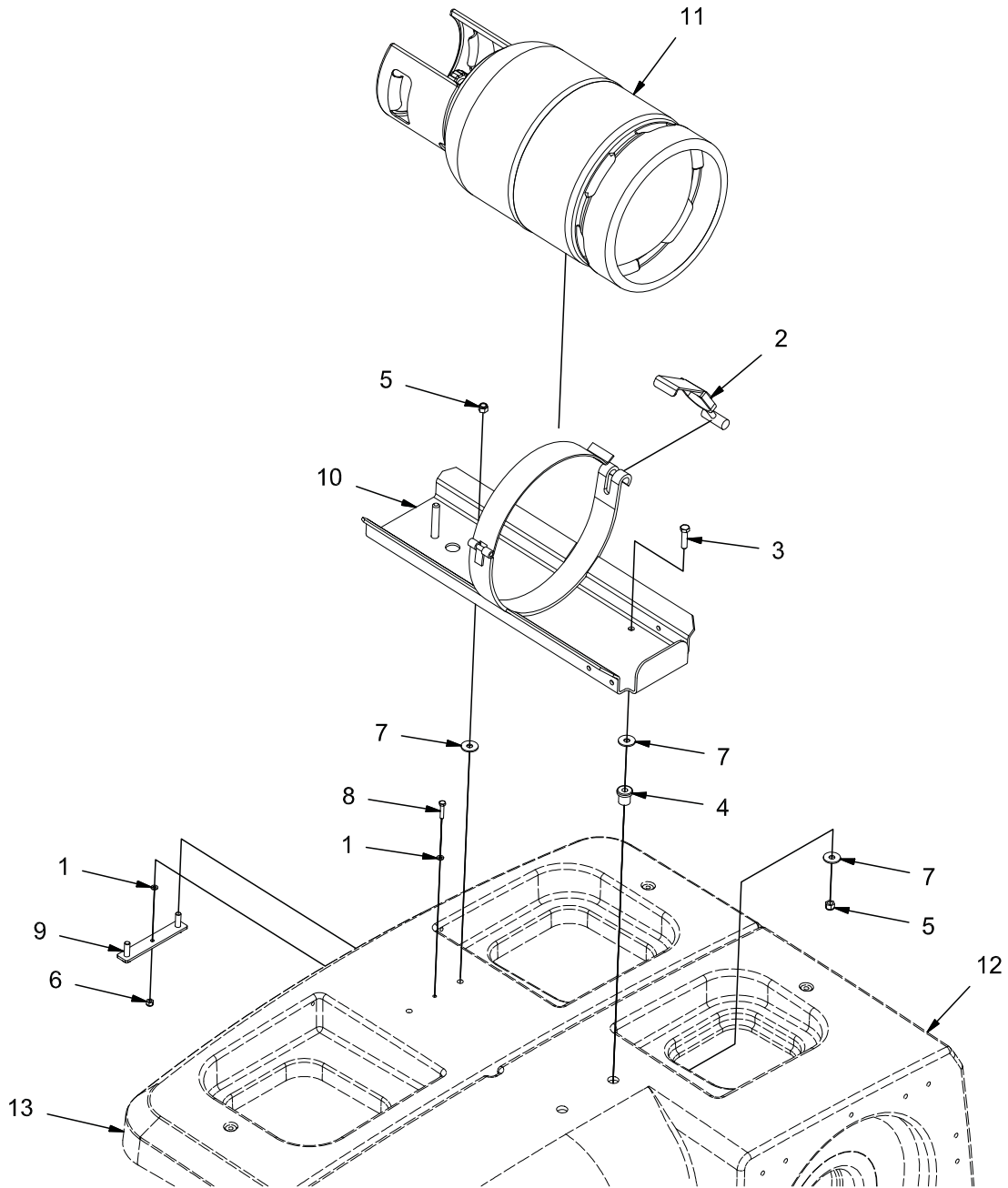

REV *

OPTION - RESERVE LPG TANK GROUP (730160)

Parts List 730160			
ITEM	PART NUMBER	QTY	DESCRIPTION
1	12310256	2	WASHER, M6, SS
2	220131	1	BUCKLE
3	3400455	2	SCREW, 3/8-16 X 1.50 HH SS
4	3300465	2	ISOLATOR, VIB
5	3400340	4	NUT, 3/8-16 ESN SS
6	600933	1	NUT, M6-1.00 ESN SS
7	717040	6	WASHER, FENDER, .413 B 1.18 OD .098 T SS
8	731050	1	BOLT, M6-100 X 30 HH SS
9	730993	1	WELDMENT, BOLT PLT
10	731010	1	WELDMENT, LPG RACK
11	REF.	-	LPG TANK
12	REF.	-	SOLUTION TANK
13	REF.	-	DEMISTER

OPTION - LIGHT GROUP WHEN CHEMICAL METERING AND
RESERVE LPG TANK INSTALLED (730189-5)

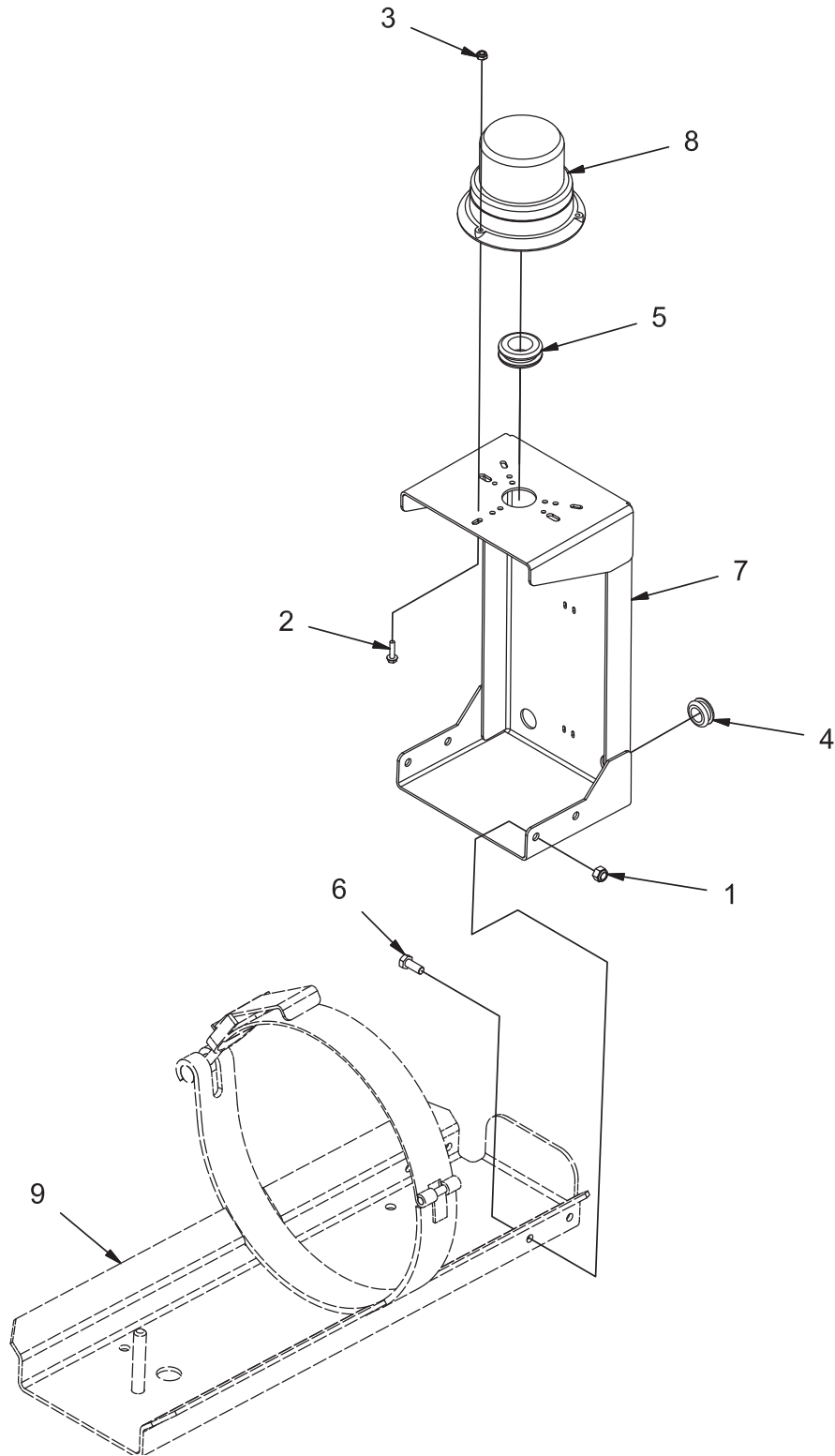

REV A

**OPTION - LIGHT GROUP WHEN CHEMICAL METERING AND
RESERVE LPG TANK INSTALLED (730189-5)**

Parts List 730189-5			
ITEM	PART NUMBER	QTY	DESCRIPTION
1	12040051	4	NUT, M8-1.25 ESN
2	3400044	3	SCR-HEX, #10-32 X .75 ZP
3	3400172	3	NUT, 10-32 ESN
4	600151	1	GROMMET, .63 ID .88 OD .25 T
5	620160	1	GROMMET, 1.00 ID .1.375 OD .25 T
6	717024	4	BOLT, M8-1.25 X 20 HH
7	731115-1	1	WELDMENT, SAFETY LIGHT MNT
8	620073-1	1	LIGHT ASSY, LED BEACON
9	REF.	-	OPTIONAL RESERVE LPG MOUNT 730160
-	748980	1	WIRING HARNESS, RESERVE LPG MNT

OPTION - BACKUP ALARM GROUP - CM, RESERVE LPG IN (730169)

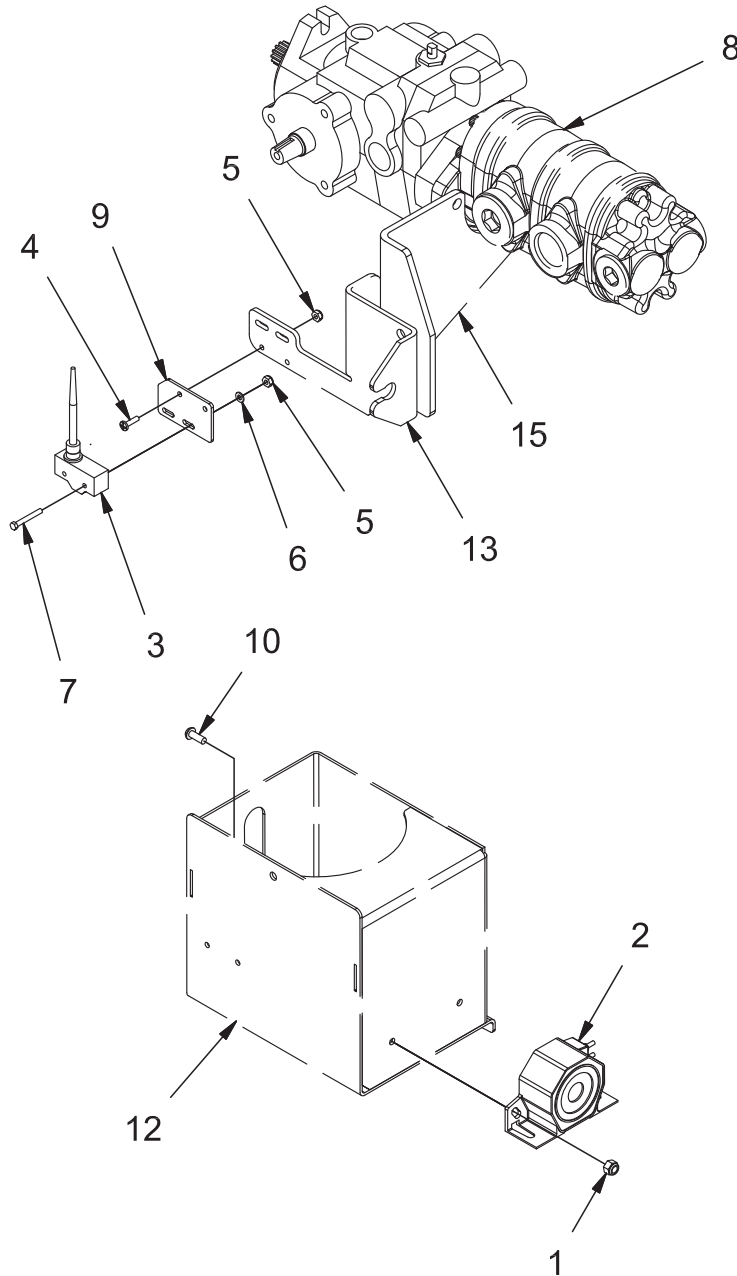

REV A

OPTION - BACKUP ALARM GROUP - CM, RESERVE LPG IN (730169)

Parts List 730169			
ITEM	PART NUMBER	QTY	DESCRIPTION
1	12040044	2	NUT, M6-1.00 ESN
2	3303002	1	ALARM, BACKUP
3	3342546-1	1	HARNESS, SWITCH, WHISKER
4	3400045	2	SCREW, #8-32 X .625 PAN HD ZP
5	3400082	4	NUT, FIBER INSERT #8-32
6	3400096	2	FLATWASHER, #8
7	620136	2	BOLT, #8-32 X 1.25 HH ZP
8	730310	1	PUMP, AUX
9	731002	1	MOUNT, REVERSE SWITCH
10	731116	2	SCREW, M6-1.00 X 16 BUTTON HD CAP ZP
11	748980	1	HARNESS, SAFETY LT & BACKUP ALARM
12	REF.	-	CHEMICAL PUMP MNT
13	REF.	-	ADJUSTER, HYDROBACK W/SW MNT
14	REF.	-	PUMP ASSEMBLY
15	REF.	-	HYDROBACK MOUNT

OPTION - PRESSURE WASHER (731457)

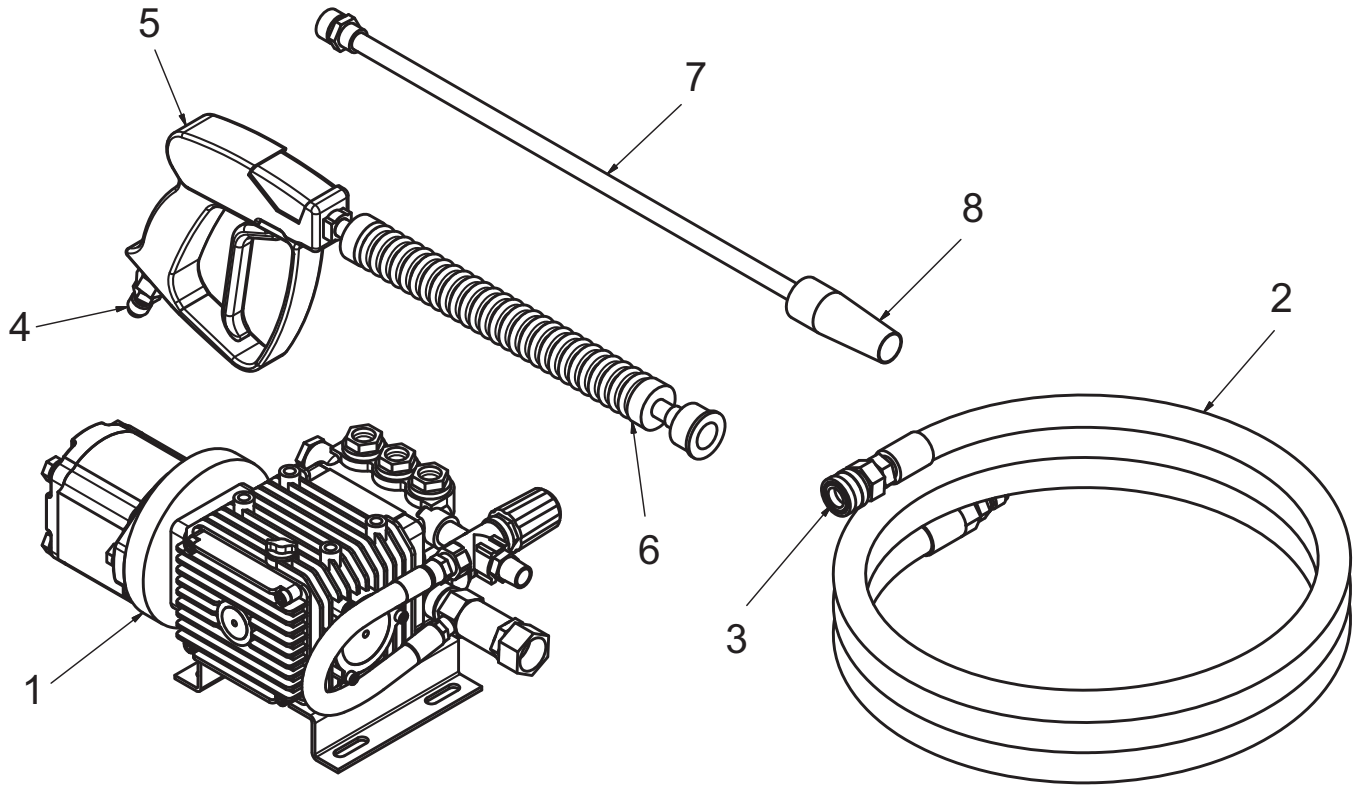

REV A

OPTION - PRESSURE WASHER (731457)

PARTS LIST			
ITEM	PART NUMBER	DESCRIPTION	QTY
1	731421	ASSEMBLY, PRESSURE WASHER PUMP	1
2	731440	HOSE, PRESSURE WASHER 50 FT	1
3	731448	QUICK DISCONNECT, SOCKET	1
4	731443	QUICK DISCONNECT PLUG, 6MPT	1
5	731444	TRIGGER GUN	1
6	731445	INSULATED LANCE	1
7	731446	LANCE	1
8	731447	ADJUSTABLE TIP	1

OPTION - DUST SUPPRESSION (731482)

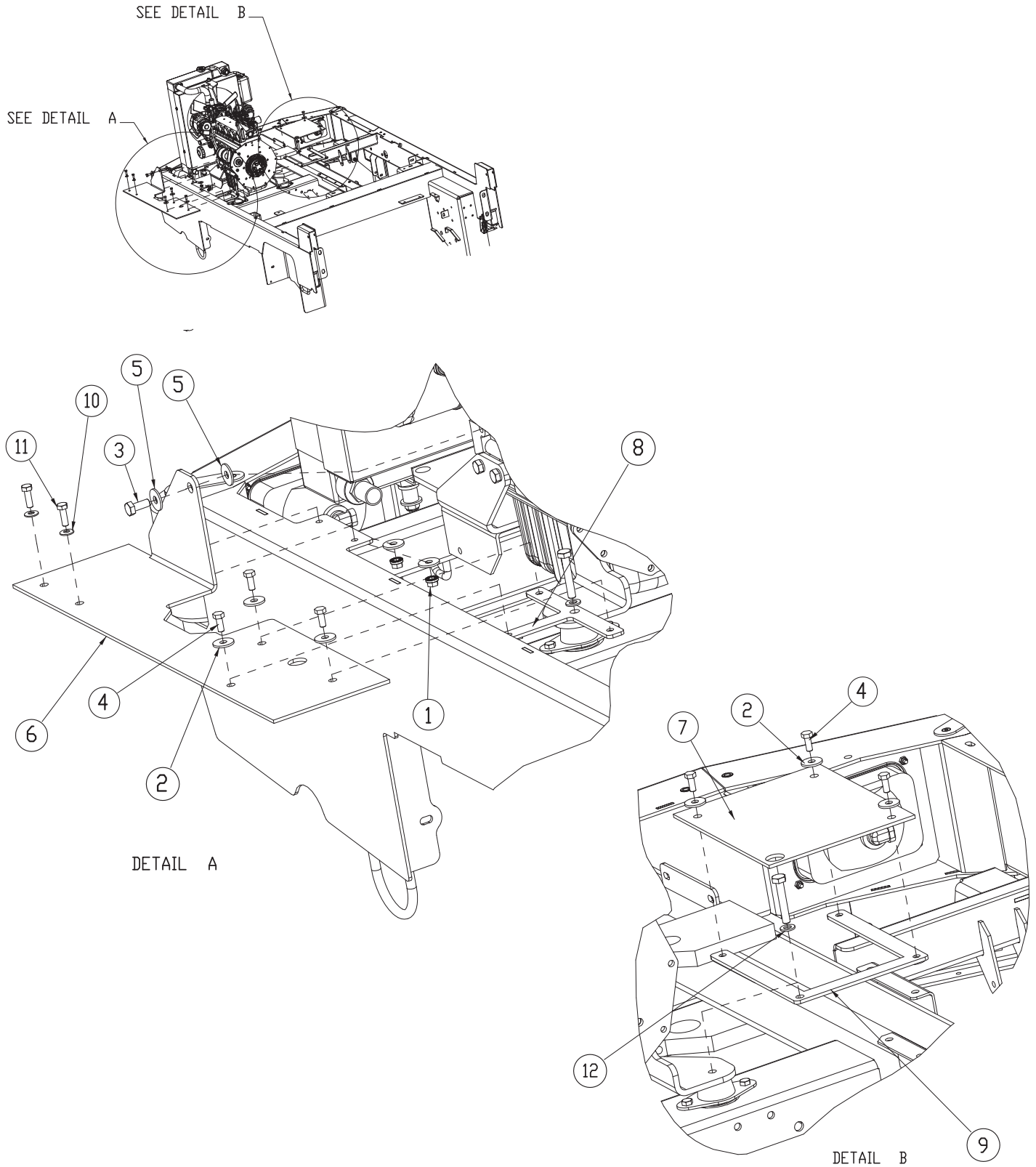

REV *

OPTION - DUST SUPPRESSION (731482)

PARTS LIST - 731482			
ITEM	PART NO.	QTY	DESCRIPTION
1	600934	2	NUT-FLANGE WIZZ M8-1.25 ZP
2	600940	8	WASHER-FENDER M8 X 24 ZP
3	620082	1	SCR-HH M10-1.25 X 25 ZP CLASS 8.8
4	717024	6	SCR-HH M8-1.25 X 20 ZP GRADE 8.8
5	717040	2	WASHER-FLAT M10.5 X 30 X 2.5 SS
6	731474	1	FLAP, DUST SUPPRESSION, LH
7	731475	1	FLAP, DUST SUPPRESSION , RH
8	731477	1	MOUNT, DUST SUPPRESSION, LH
9	731480	1	MOUNT, DUST SUPPRESSION, RH
10	3400384	2	WASHER-CONICAL SPRING 5/16
11	11038247	2	SCR-HH M8-1.25 X 25 ZP CLASS 8.8
12	12310058	2	WASHER-FLAT M10.5 X 20 X 2 ZP

MISCELLANEOUS ADDITIONAL OPTIONS

730019	OPT - SOFTSIDE CAB <i>(REPLACEMENT SNAPS 3400412)</i>
730044	OPT - SIPED TIRES
730045	OPT - PARKING BRAKE
730046	OPT - LH SIDE MIRROR
730062	OPT-ENGINE SHUTDOWN, DSL
730165	OPT - NON MARKING TIRES, NAUTILUS & HD
731467	OPT - NOISE REDUCTION
730123-HF	OPT - HIGH FLOW SOLUTION CONTROL

LAYOUTS - ELECTRICAL/HYDRAULIC
ELECTRICAL SCHEMATIC LAYOUT

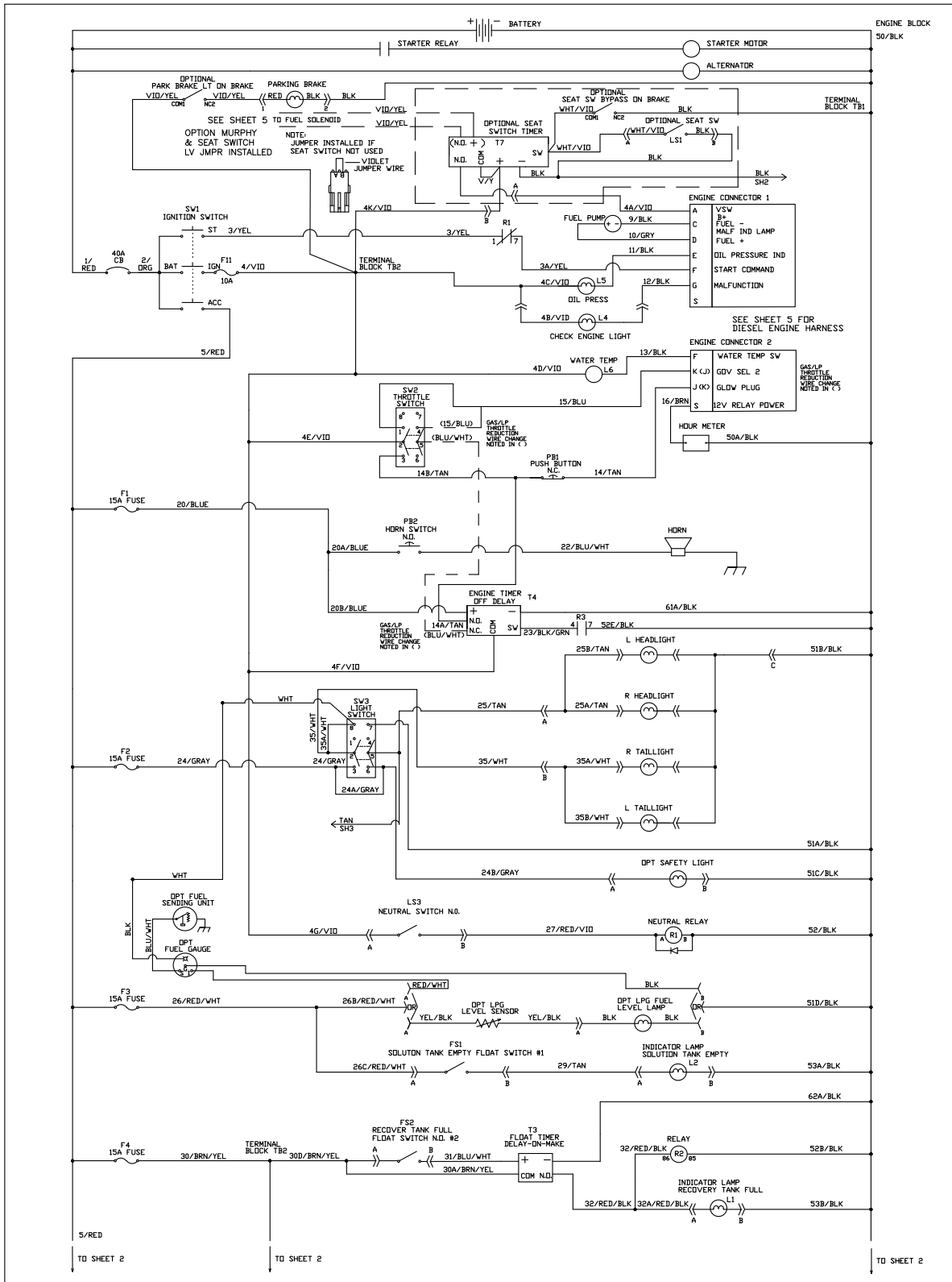

748992-1 REV G

ELECTRICAL SCHEMATIC LAYOUT

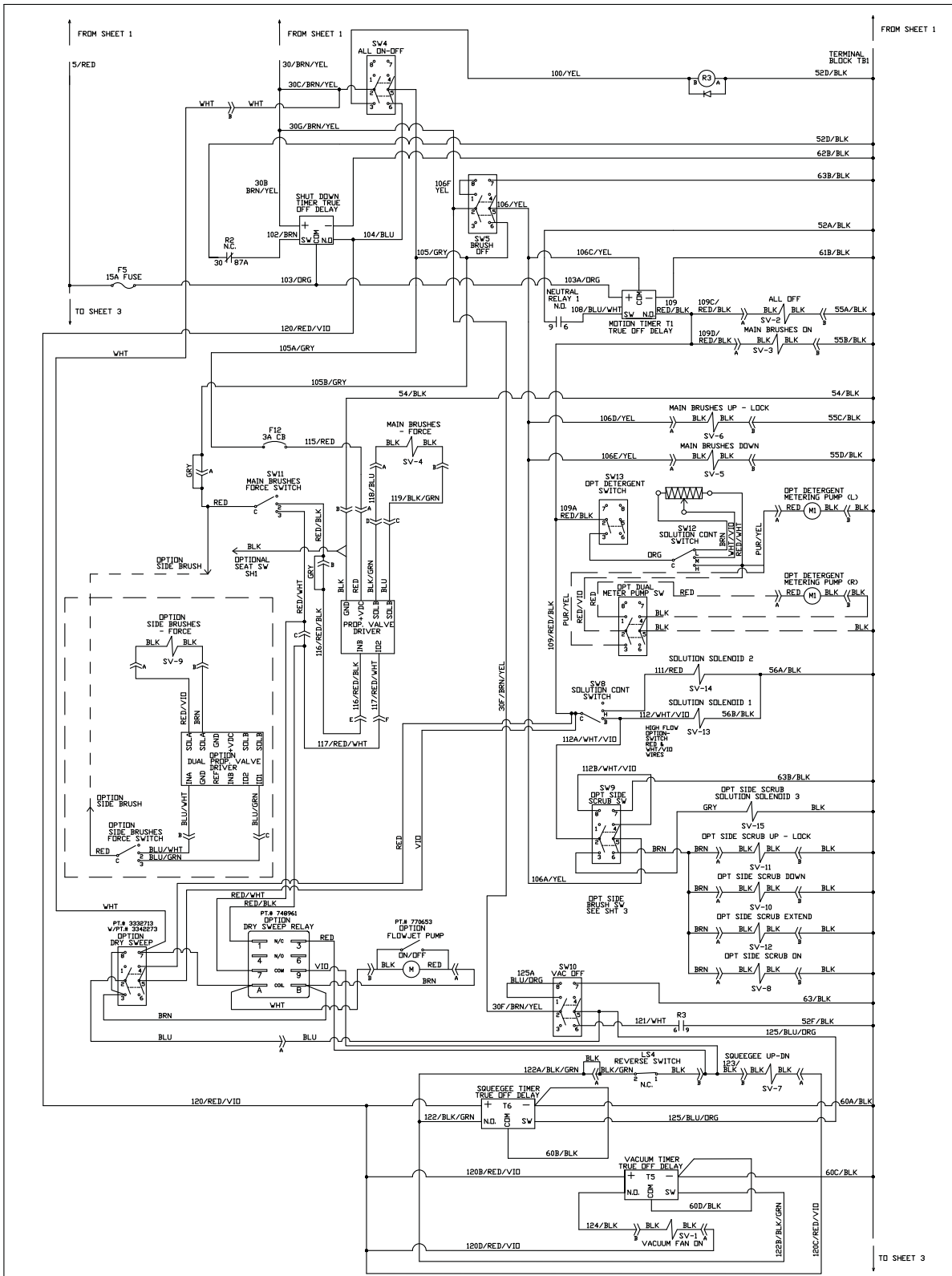

ELECTRICAL SCHEMATIC LAYOUT

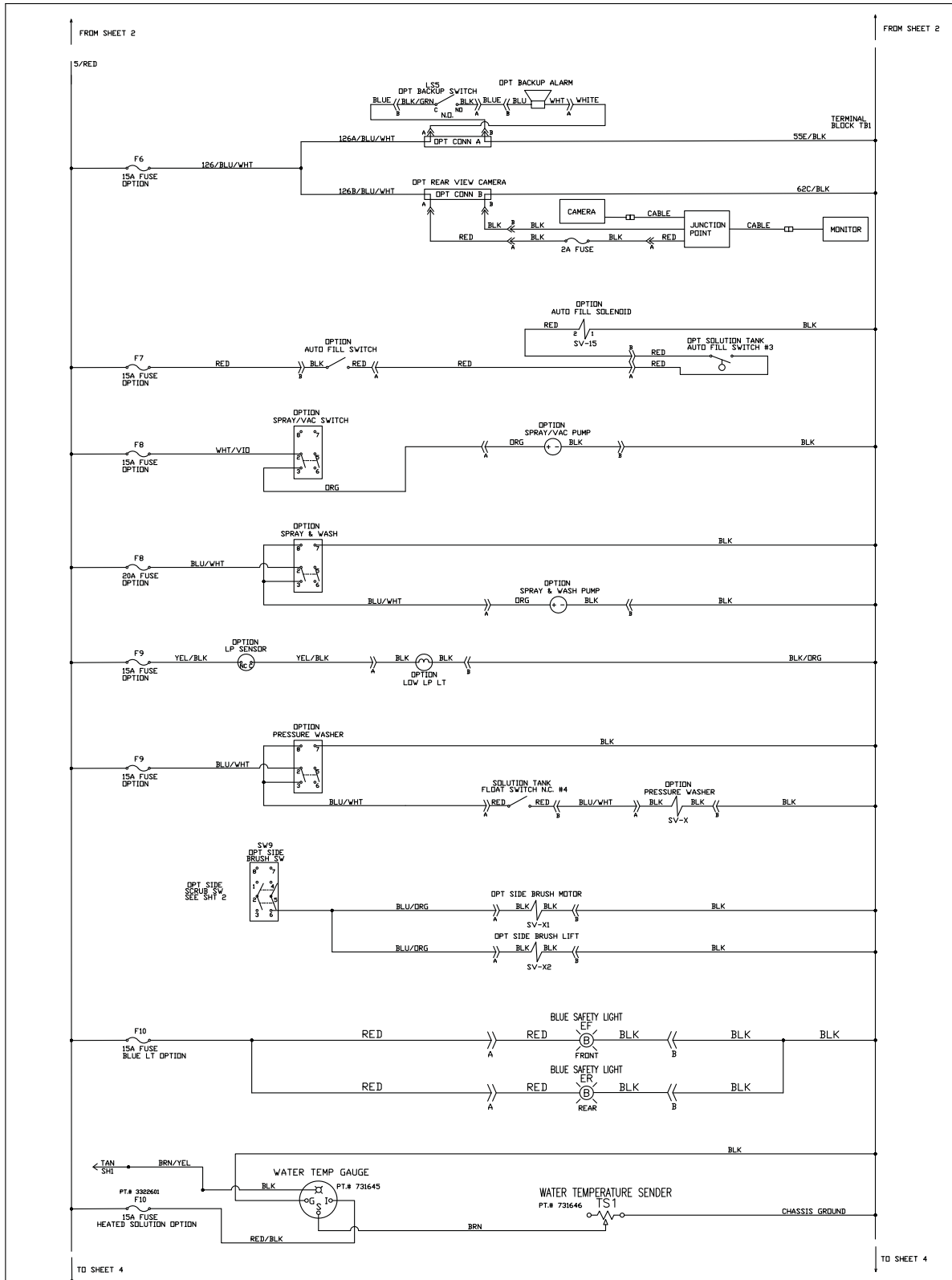

ELECTRICAL SCHEMATIC LAYOUT

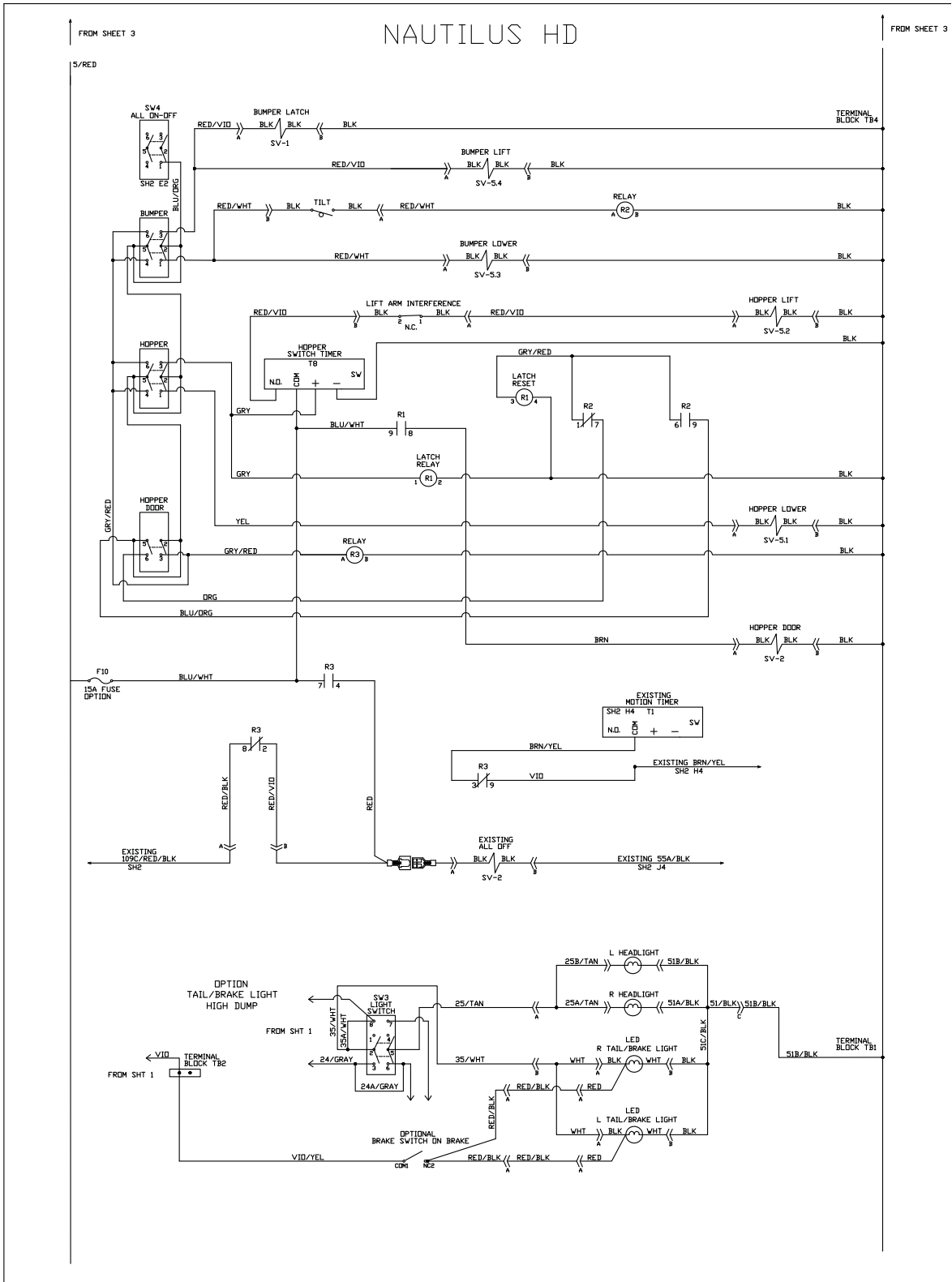

ELECTRICAL SCHEMATIC LAYOUT (POINT TO POINT WIRING)

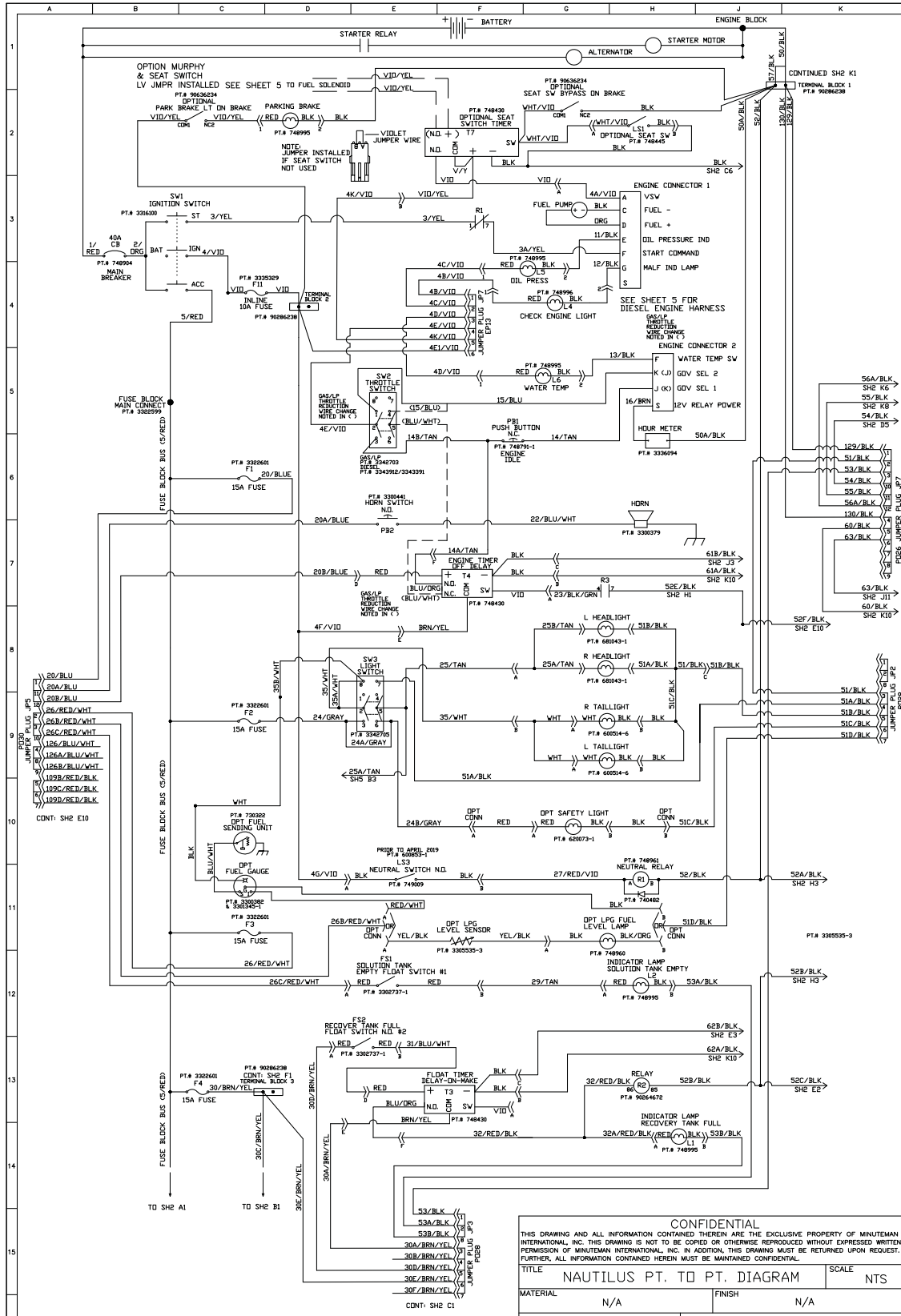

748992 REV K

ELECTRICAL SCHEMATIC LAYOUT (POINT TO POINT WIRING)

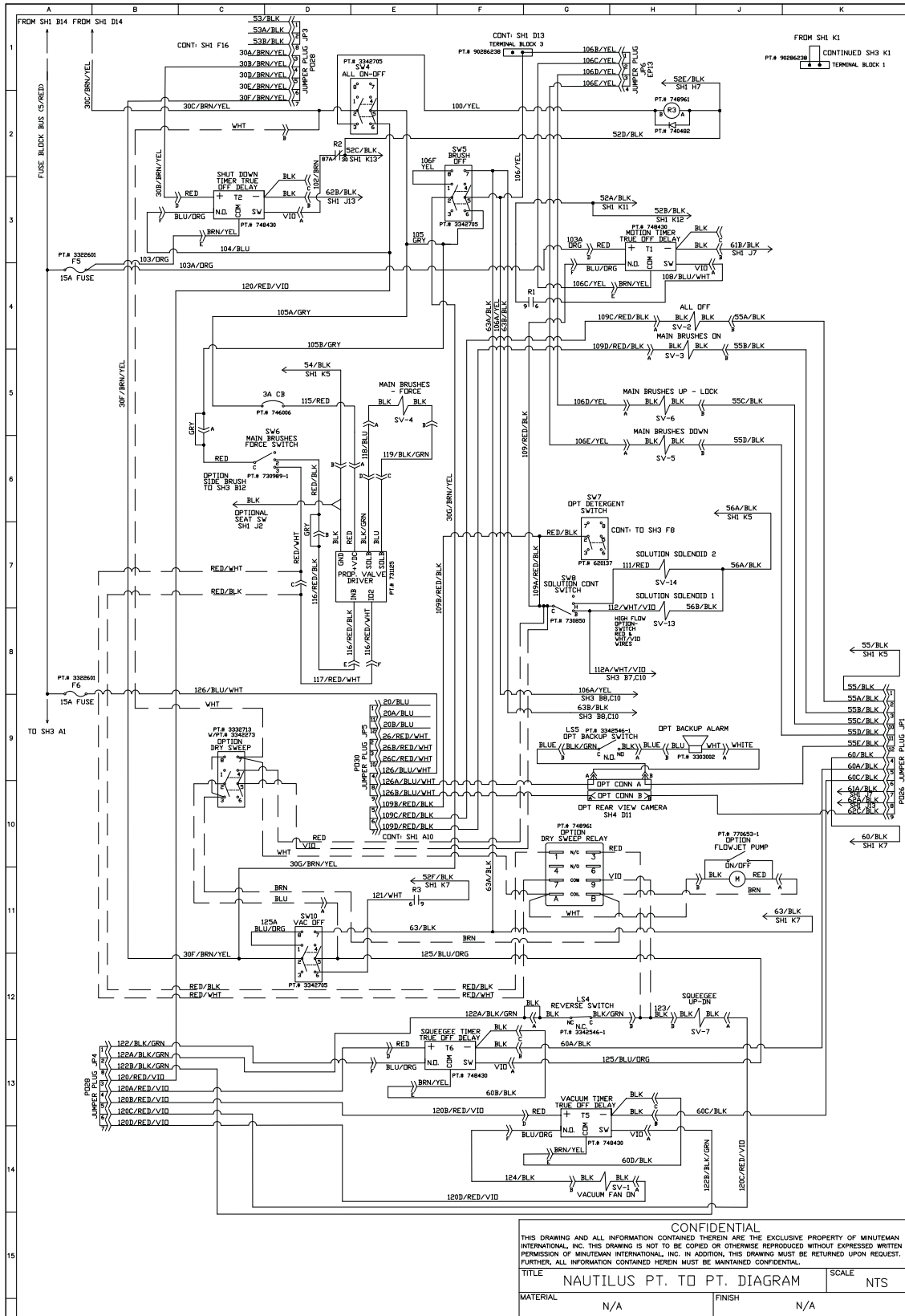

ELECTRICAL SCHEMATIC LAYOUT (POINT TO POINT WIRING)

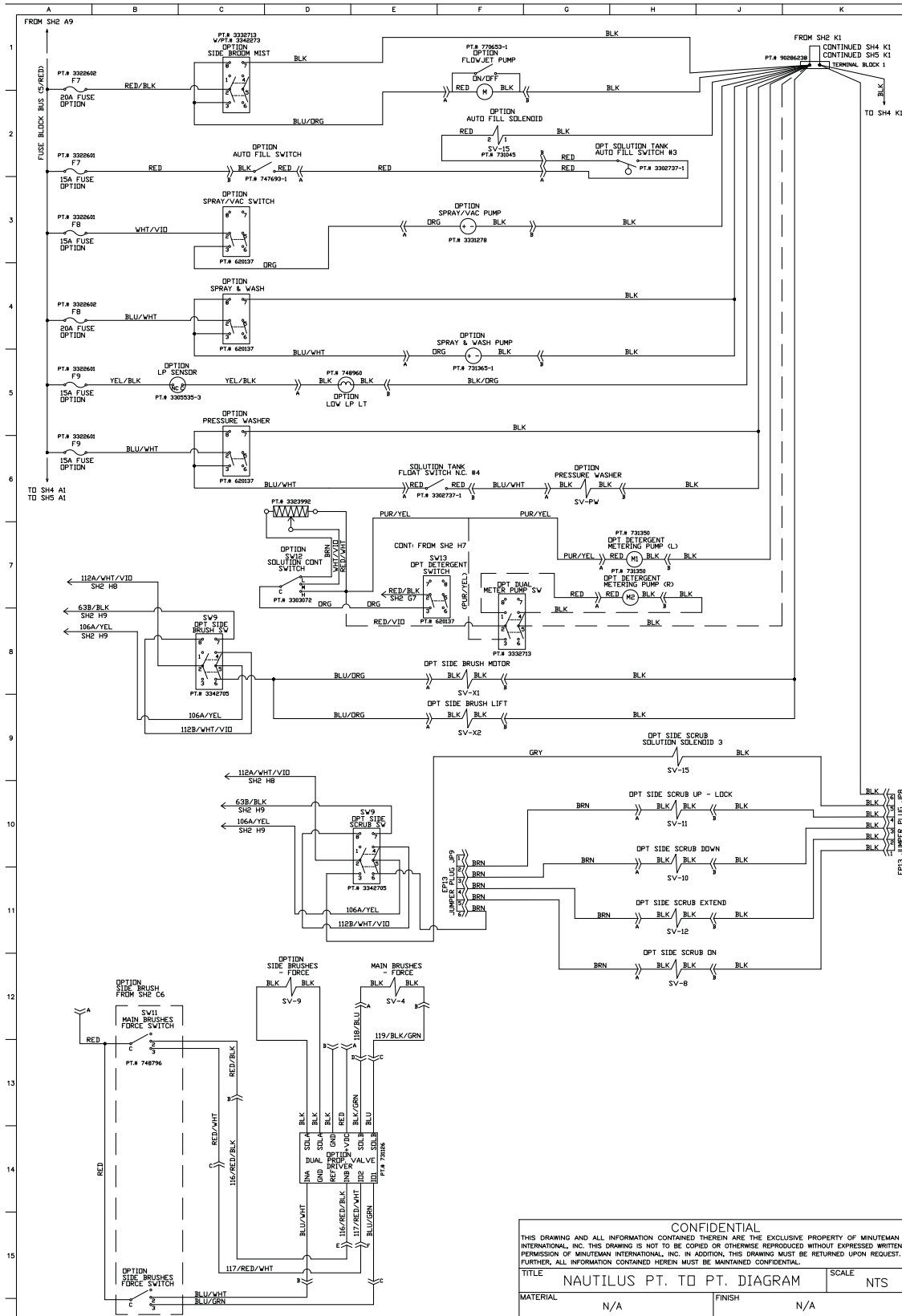

CONFIDENTIAL

THIS DRAWING AND ALL INFORMATION CONTAINED HEREIN ARE THE EXCLUSIVE PROPERTY OF MINUTEMAN INTERNATIONAL, INC. THIS DRAWING IS NOT TO BE COPIED OR OTHERWISE REPRODUCED WITHOUT EXPRESSED WRITTEN PERMISSION OF MINUTEMAN INTERNATIONAL, INC. IN ADDITION, THIS DRAWING MUST BE RETURNED UPON REQUEST. FURTHER, ALL INFORMATION CONTAINED HEREIN MUST BE MAINTAINED CONFIDENTIAL.

TITLE	NAUTILUS PT. TO PT. DIAGRAM	SCALE	NTS
MATERIAL	N/A	FINISH	N/A

ELECTRICAL SCHEMATIC LAYOUT (POINT TO POINT WIRING)

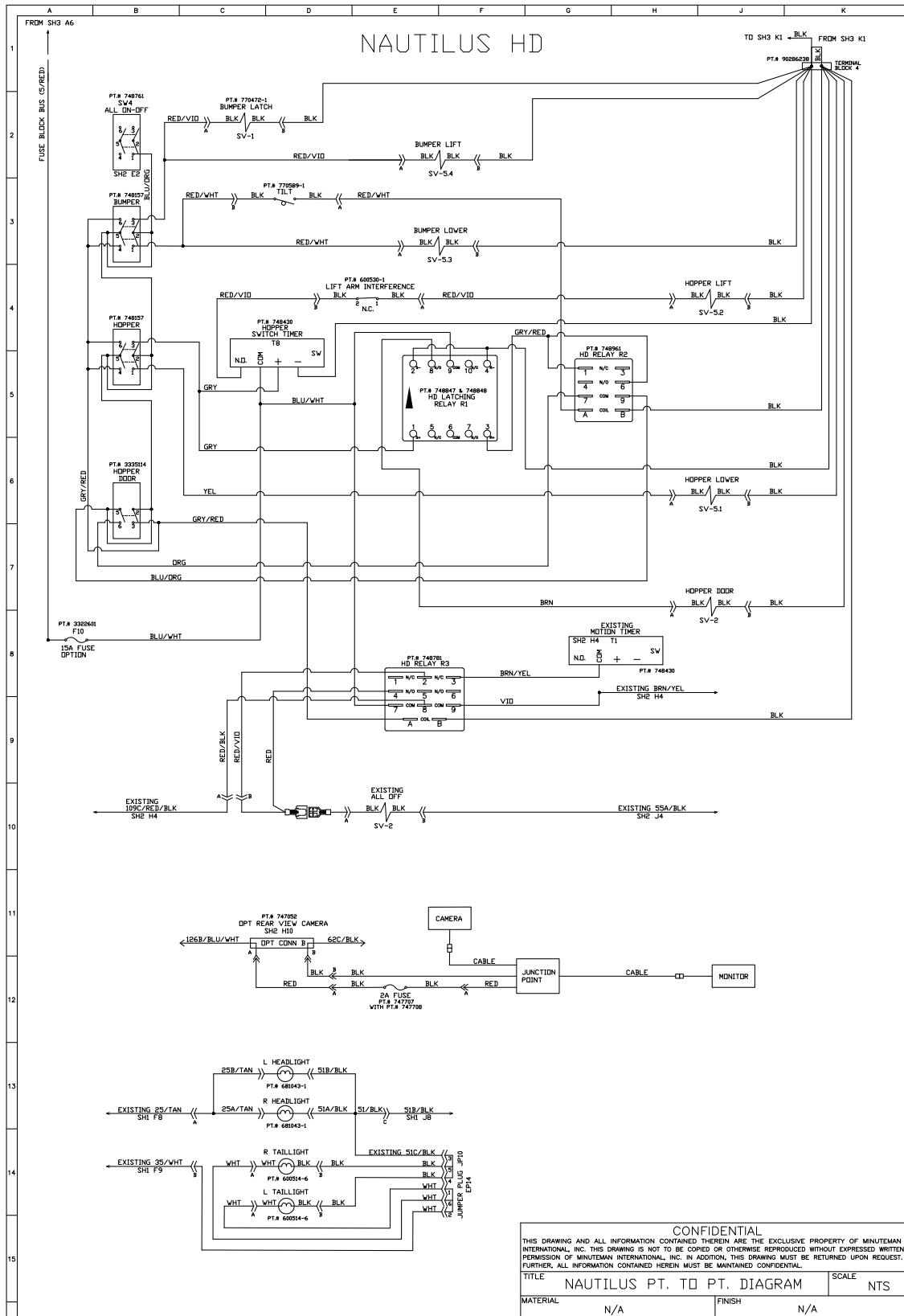

ELECTRICAL SCHEMATIC LAYOUT (POINT TO POINT WIRING)

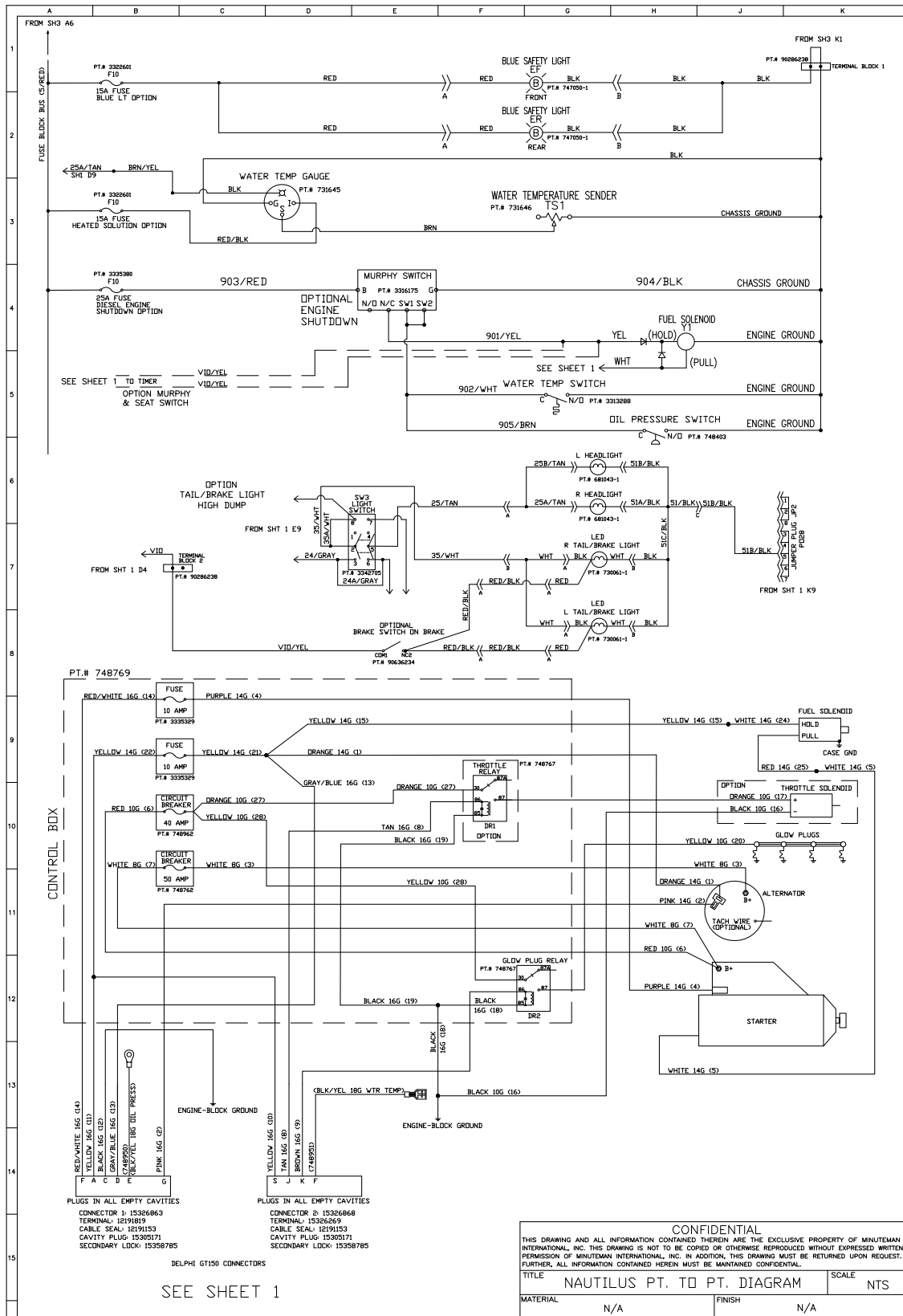

SEE SHEET 1

HYDRAULIC SYSTEM LAYOUT

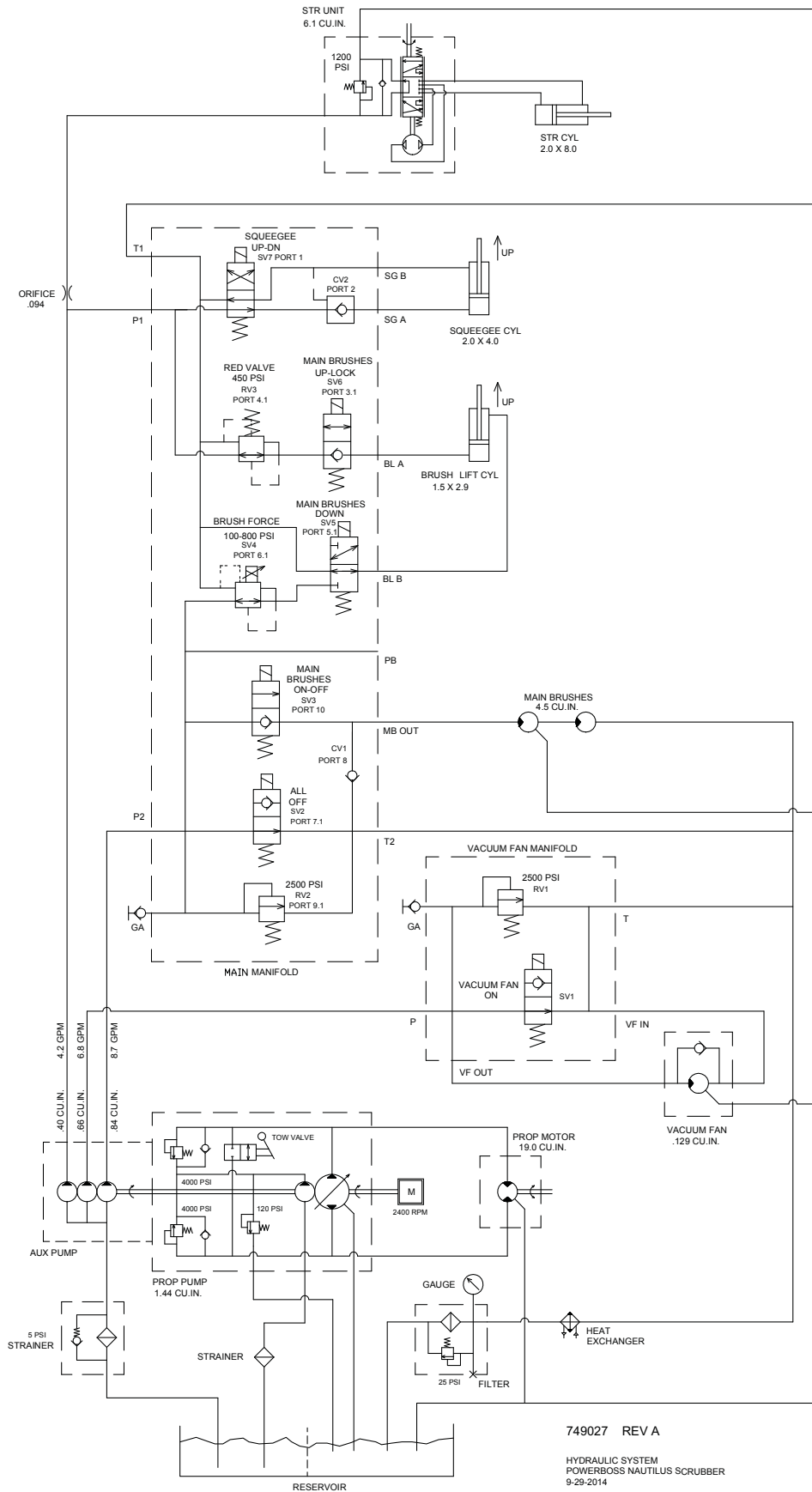

HYDRAULIC SYSTEM LAYOUT WITH OPTIONAL SIDE SCRUB BRUSH

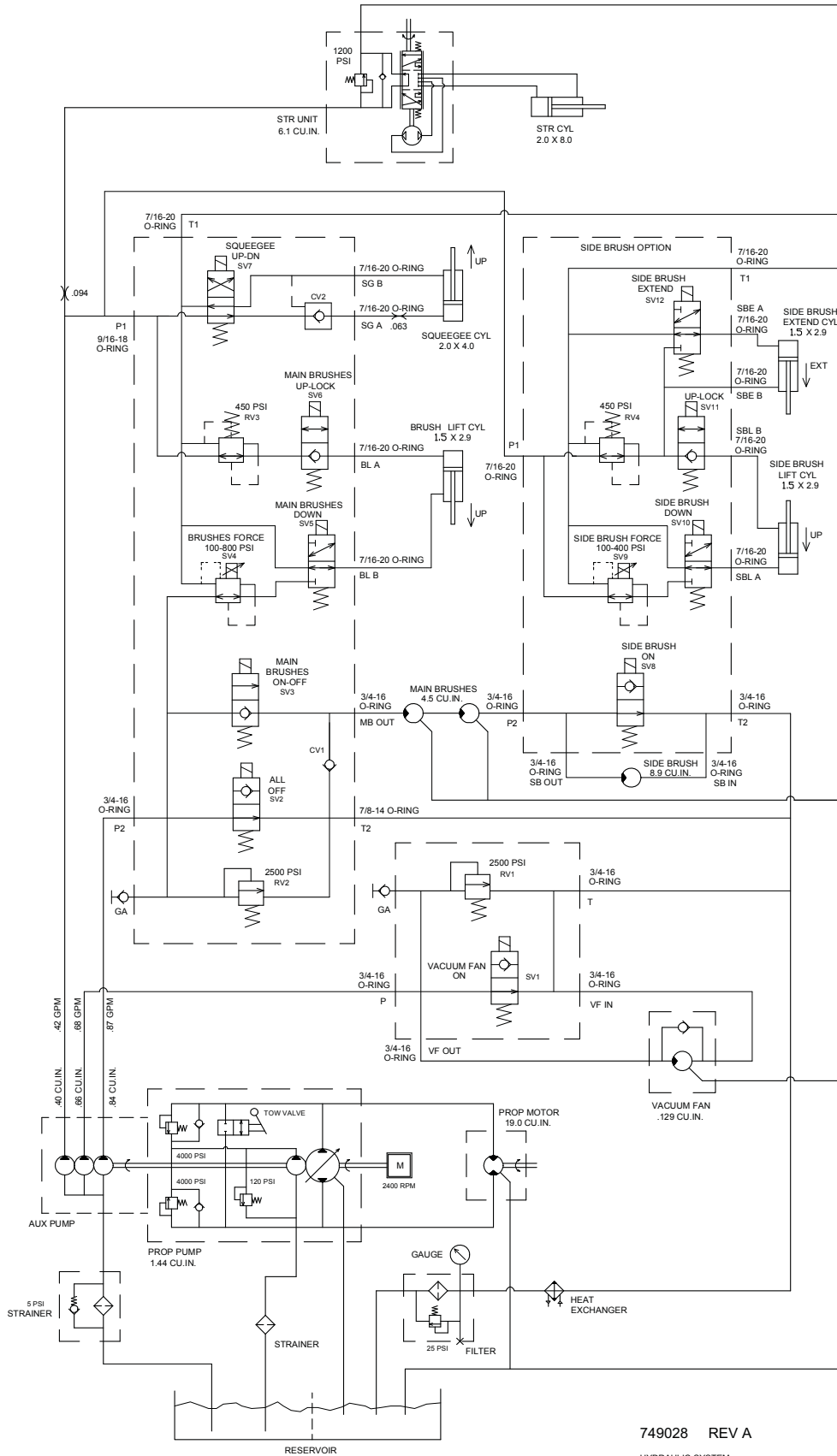

749028 REV A

HYDRAULIC SYSTEM
WITH OPTIONAL SIDE SCRUB BRUSH
POWERBOSS NAUTILUS SCRUBBER
5-22-2014

PowerBoss[®]
The Power of Clean

'The Power of Clean''

**PowerBoss® is a Full Line Manufacturer of Sweepers and Scrubbers,
for Industrial Facilities.**

PowerBoss®, Minuteman International, Inc. 14N845 U.S. Route 20 Pingree Grove, Illinois 60140

Phone: 800-323-9420 www.PowerBoss.com Email: tech@powerboss.com

A Member of the Hako Group

Nautilus Rider Scrubber/Sweeper #988749 Rev. L 01/20

PowerBoss® Copyright 2014-2015